

CV12-20 Check Valve

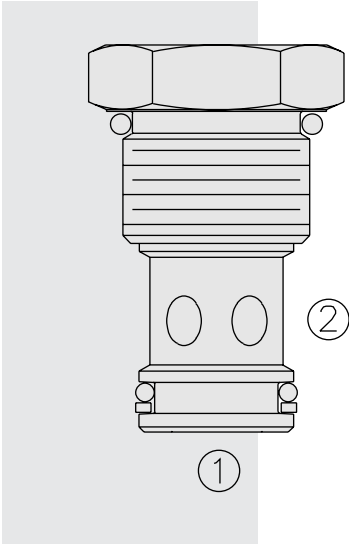

DESCRIPTION

A screw-in, cartridge-style, hydraulic check valve for use as a blocking or load-holding device.

OPERATION

The **CV12-20** allows flow passage from ① to ②, while normally blocking oil flow in the opposite direction.

The cartridge has a fully guided check which is spring-biased closed until sufficient pressure is applied at ① to open to ②.

FEATURES

- Hardened seat for long life and low leakage.
- Optional bias springs for back-pressure application flexibility.
- Fully guided check assembly.
- Cost effective cavity.

RATINGS

Operating Pressure: 240 bar (3500 psi)

Proof Pressure: 420 bar (6090 psi)

Flow: See Performance Chart

Internal Leakage: 0.25 cc/minute (5 drops/minute) max. at 240 bar (3500 psi)

Crack Pressure Defined: Gauge bar (psi) evident at ① at 16.4 cc/minute (1 cu. in./minute) attained

Standard Bias Springs at Crack: 0.34 bar (5 psi); 1.7 bar (25 psi); 4.1 bar (60 psi)

Temperature: -40 to 120°C

Filtration: See page 9.010.1

Fluids: Mineral-based or synthetics with lubricating properties at viscosities of 7.4 to 420 cSt (50 to 2000 sus); See Temperature and Oil Viscosity, page 9.060.1

Installation: No restrictions; See page 9.020.1

Cavity: VC12-2; See page 9.112.1

Cavity Tool: CT12-2XX; See page 8.600.1

Seal Kit: SK12-2X-T; See page 8.650.1

SYMBOLS

USASI:

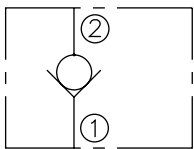

ISO:

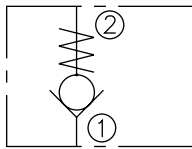

PERFORMANCE (Cartridge Only)

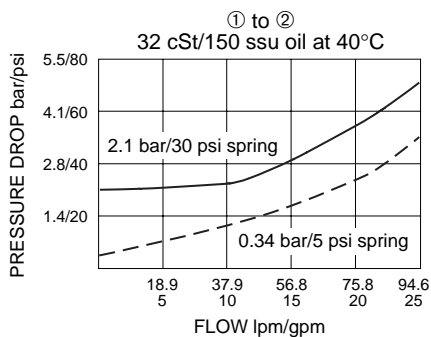

DIMENSIONS

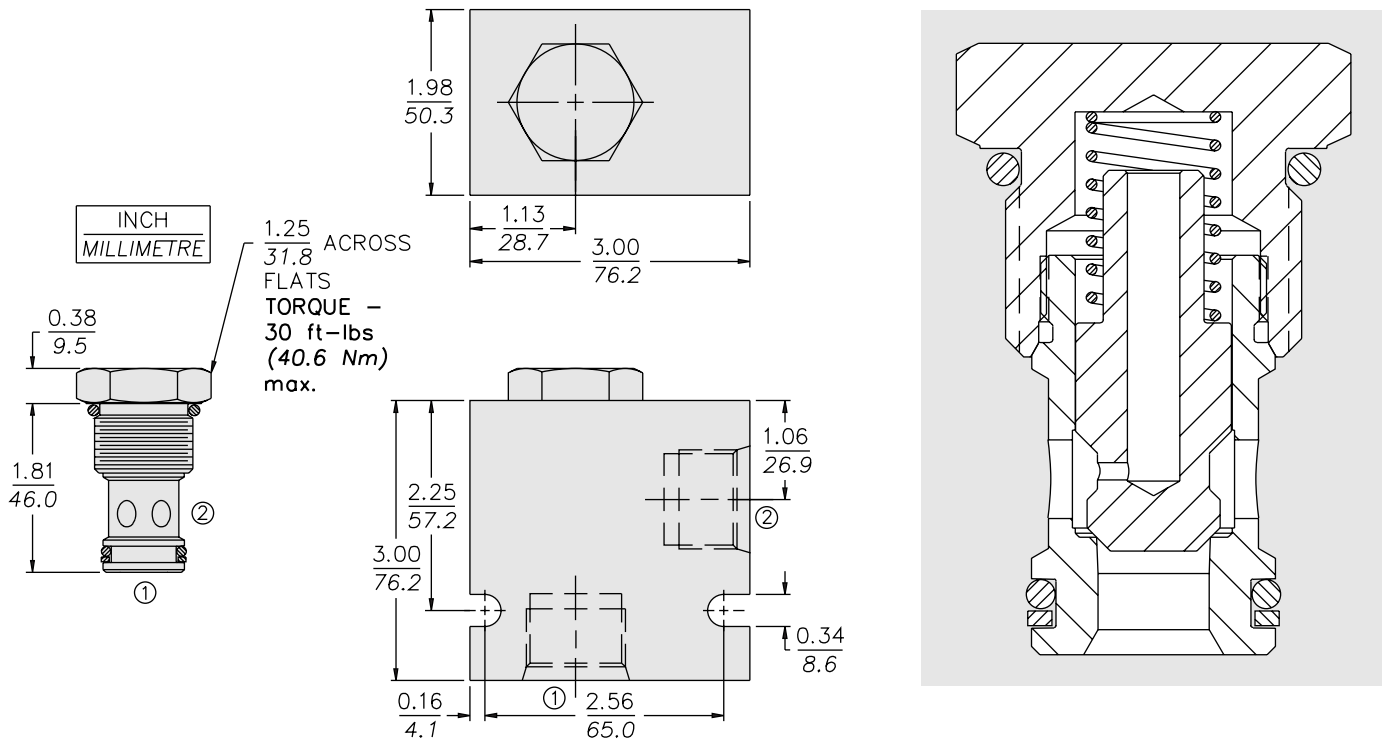

MATERIALS

Cartridge: Weight: 0.18 kg. (0.40 lbs.)
Steel with hardened work surfaces.
Zinc-plated exposed surfaces.
Buna N O-rings and polyester
elastomer back-ups standard.

Standard Ported Body: Weight:
0.57 kg. (1.25 lbs.) Anodized high-
strength 6061 T6 aluminum alloy,
rated to 207 bar (3000 psi). Ductile
iron bodies available; dimensions
may differ. See page 8.012.1

TO ORDER

CV12-20 - - -

Porting

Cartridge Only **0**
SAE 10 **10T**
SAE 12 **12T**
SAE 16 **16T**

Bias Spring*

5 0.34 bar (5 psi)
25 1.7 bar (25 psi)
30 2.1 bar (30 psi)
60 4.1 bar (60 psi)

*Additional springs in development;
Consult factory.

Seals

N Buna N (Std.)
V Fluorocarbon