

## CV08-21 Check Valve

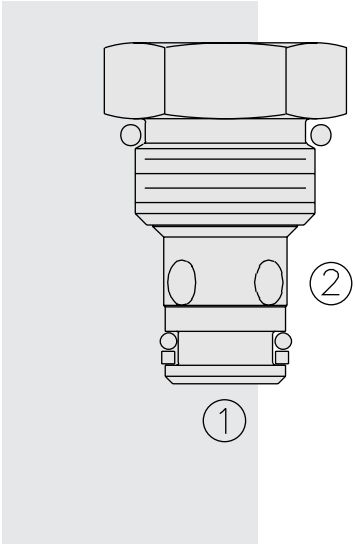

### DESCRIPTION

A screw-in, cartridge-style, hydraulic check valve for use as a blocking or load-holding device.

### OPERATION

The CV08-21 allows flow passage from ② to ①, while normally blocking oil flow in the opposite direction.

The cartridge has a fully guided poppet which is spring-biased closed until sufficient pressure is applied at ② to open to ①.

### FEATURES

- Hardened seat for long life and low leakage.
- Fully guided poppet.
- Compact size.

### RATINGS

**Operating Pressure:** 240 bar (3500 psi)

**Flow:** See Performance Chart

**Internal Leakage:** 0.25 cc/minute (5 drops/minute) max. at 240 bar (3500 psi)

**Crack Pressure Defined:** Gauge bar (psi) evident at ② at 16.4 cc/minute (1 cu. in./minute) attained

**Standard Bias Spring at Crack:** 2.1 bar (30 psi) nominal. Actual cracking pressure may vary from 1.9 to 2.8 bar (27 to 40 psi); valves which are not actuated for a period of time may initially crack at higher than subsequent cracking pressures.

**Temperature:** -40 to 120°C

**Filtration:** See page 9.010.1

**Fluids:** Mineral-based or synthetics with lubricating properties at viscosities of 7.4 to 420 cSt (50 to 2000 sus); See Temperature and Oil Viscosity, page 9.060.1

**Installation:** No restrictions; See page 9.020.1

**Cavity:** VC08-2; See page 9.108.1

**Cavity Tool:** CT08-2XX; See page 8.600.1

**Seal Kit:** SK08-2X-B; See page 8.650.1

### SYMBOLS

USASI:

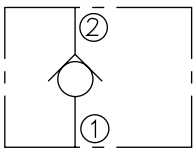

ISO:

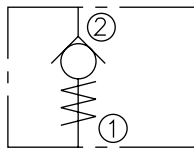

### PERFORMANCE (Cartridge Only)

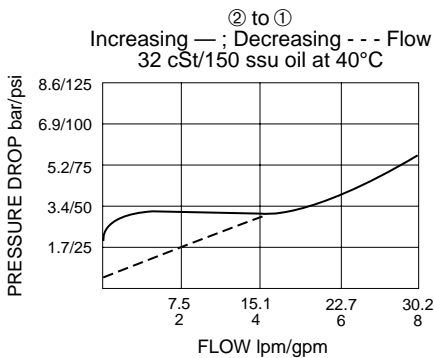

**DIMENSIONS**

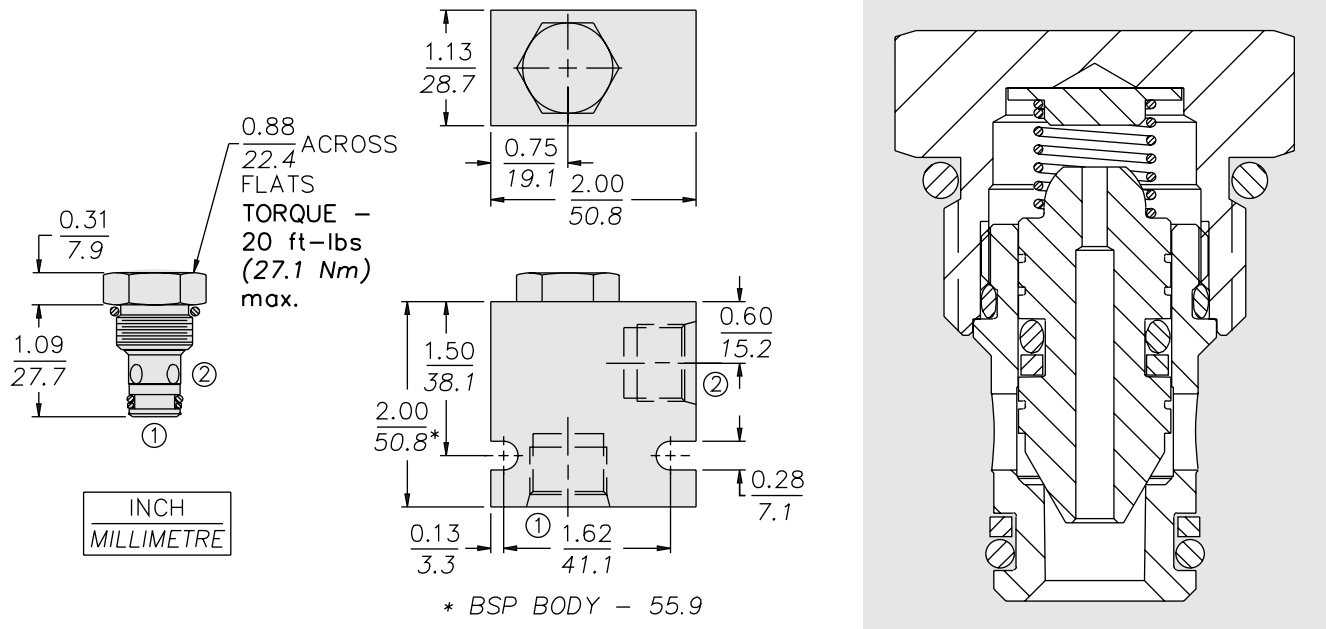

**MATERIALS**

**Cartridge:** Weight: 0.05 kg. (0.12 lbs.)  
Steel with hardened work surfaces.  
Zinc-plated exposed surfaces.  
Buna N O-rings and back-up  
standard.

**Standard Ported Body:** Weight:  
0.16 kg. (0.35 lbs.) Anodized high-  
strength 6061 T6 aluminum alloy,  
rated to 207 bar (3000 psi). Ductile  
iron bodies available; dimensions  
may differ. See page 8.008.1

**TO ORDER**

