

CV10-21 Check Valve

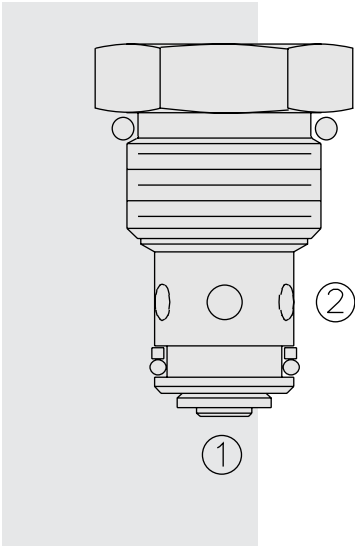

DESCRIPTION

A screw-in, cartridge-style, hydraulic check valve for use as a blocking or load-holding device.

OPERATION

The CV10-21 allows flow passage from ② to ①, while blocking flow from ① to ②. The cartridge has a fully guided check which is spring-biased closed until sufficient pressure is applied at ② to open to ①.

Note: High shock/rapid actuation applications may require a high load option. Consult factory.

FEATURES

- Low check mass for anti-cavitation applications.
- Hardened seat for long life and low leakage.
- Optional bias springs for back-pressure application flexibility.
- Industry common cavity.

RATINGS

Operating Pressure: 210 bar (3000 psi)

Proof Pressure: 420 bar (6090 psi)

Flow: See Performance Chart

Internal Leakage: 0.25 cc/minute (5 drops/minute) max. at 210 bar (3000 psi)

Crack Pressure Defined: Gauge psi evident at ② at 16.4 cc/minute (1 cu. in./minute) attained at ①

Standard Bias Springs at Crack: 0.3 bar (4 psi); 1.7 bar (25 psi); 3.8 bar(55 psi)

Temperature: -40 to 120°C

Filtration: See page 9.010.1

Fluids: Mineral-based or synthetics with lubricating properties at viscosities of 7.4 to 420 cSt (50 to 2000 sus); See Temperature and Oil Viscosity, page 9.060.1

Installation: See note in dimension drawing regarding minimum pilot drill diameter. Use of 10-size 2P standard ported body is prohibited.

Cavity: VC10-2; See page 9.110.1 (Cavity Variation "A")

Cavity Tool: CT10-2XX; See page 8.600.1

Seal Kit: SK10-2X-B; See page 8.650.1

SYMBOLS

USASI:

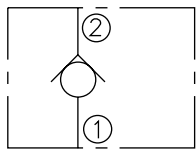

ISO:

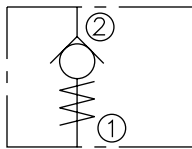

PERFORMANCE (Cartridge Only)

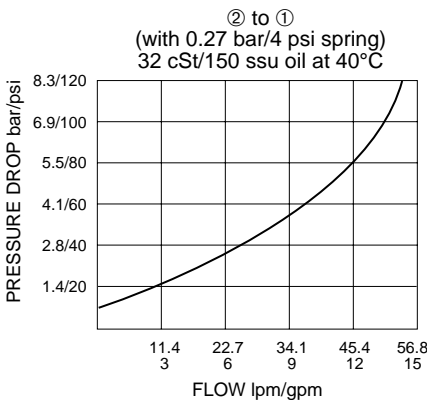

Note: This model, the CV10-21, will be discontinued. New applications should use the newer model CV10-24; see page 4.040.1.

DIMENSIONS

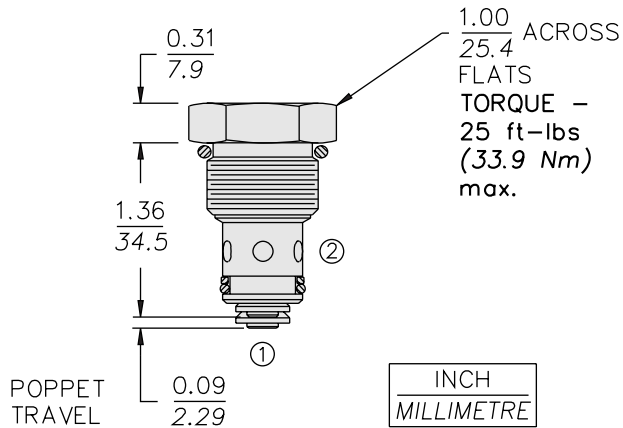

ORIFICE DISC MAY NOT BE USED WITH THIS PRODUCT.

MATERIALS

Cartridge: Weight: 0.08 kg. (0.17 lbs.)
 Steel with hardened work surfaces.
 Zinc-plated exposed surfaces;
 Buna N O-rings and polyester elastomer back-ups standard.

TO ORDER

