

## PD12-44 Piloted 2-Way Spool

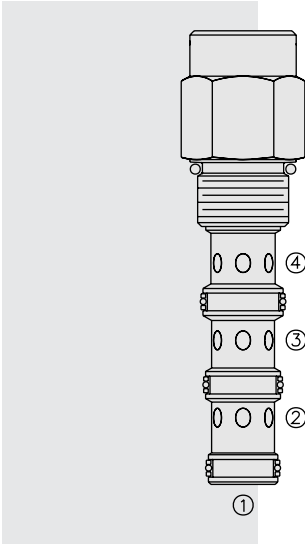

### DESCRIPTION

A screw-in, cartridge-style, pilot-operated, spool-type, hydraulic directional valve for two-way circuits requiring remote pilot actuation.

### OPERATION

In neutral (unpiloted), the **PD12-44** blocks flow from ③ to ② bidirectionally. The spring chamber is directed to port ④, which is internally O-ring sealed from the cartridge flow paths.

On remote pilot signal at ①, the valve shifts to open from ② to ③, bidirectionally. Any pressure on port ④ is added to the spring value.

### FEATURES

- Hardened spool and cage for long life.
- Cost effective cavity.

### RATINGS

**Operating Pressure:** 240 bar (3500 psi)

**Flow:** See Performance Chart

**Internal Leakage:** 115 cc/minute (7 cu. in./minute) max. at 207 bar (3000 psi)

**Pilot Pressure Required Using 7.6 bar (110 psi) Spring:**

To Spool Crossover: 7.6 bar (110 psi)

To Full Spool Shift: 9.1 bar (132 psi)

**Oil Volume Required to Full Shift:** 1.32 cc (0.08 cu. in.)

**Temperature:** -40 to 120°C with standard Buna seals

**Filtration:** See page 9.010.1

**Fluids:** Mineral-based or synthetics with lubricating properties at viscosities of 7.4 to 420 cSt (50 to 2000 sus); See Temperature and Oil Viscosity, page 9.060.1

**Installation:** No restrictions; See page 9.020.1

**Cavity:** VC12-4; See page 9.112.2

**Cavity Tool:** CT12-4XX; See page 8.600.1

**Seal Kit:** SK12-4X-MMM; See page 8.650.1

### SYMBOLS

#### USASI:

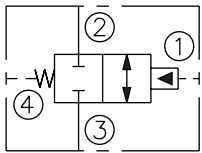

#### ISO:

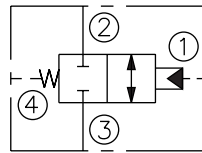

### PERFORMANCE (Cartridge Only)

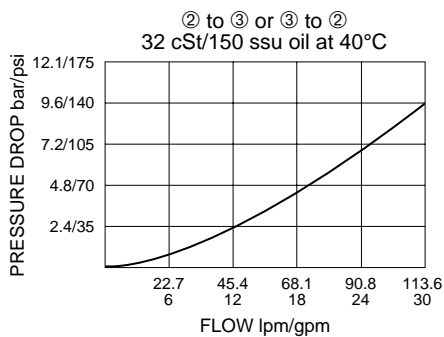

**DIMENSIONS**

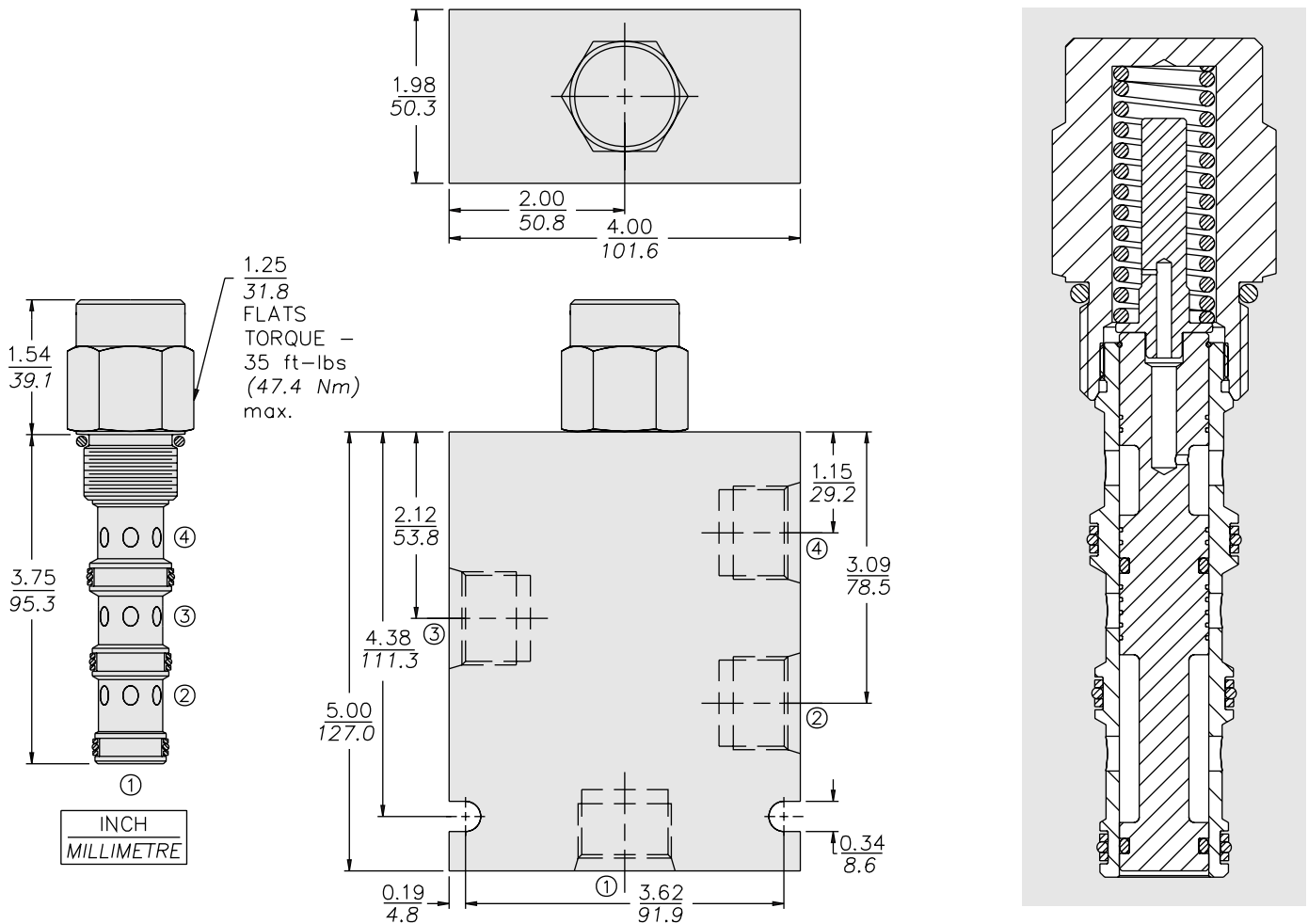

**MATERIALS**

**Cartridge:** Weight: 0.28 kg. (0.61 lbs.)  
Steel with hardened work surfaces.  
Zinc-plated exposed surfaces.  
Buna N O-rings and polyester elastomer back-ups standard.

**Standard Ported Body:** Weight:  
1.5 kg. (3.3 lbs.); Anodized high-strength 6061 T6 aluminum alloy, rated to 207 bar (3000 psi).  
Ductile iron steel bodies available; dimensions may differ.  
See page 8.012.1

**TO ORDER**

PD12-44 -

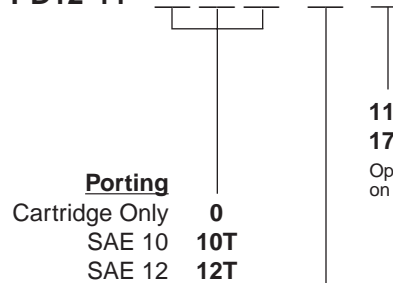

**Bias Spring**

- 110 7.6 bar (110 psi)
- 170 11.7 bar (170 psi)

Optional bias springs considered on OEM request.

**Seals**

- N Buna N (Std.)
- NS Buna N with Sealed Spool
- V Fluorocarbon
- VS Fluorocarbon with Sealed Spool