

PD16-45 Piloted 2-Way Spool

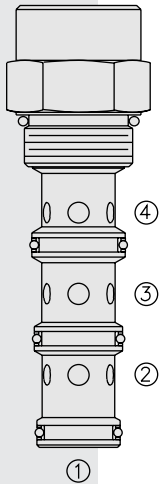

DESCRIPTION

A screw-in, cartridge-style, pilot-operated, spool-type, hydraulic directional valve for two-way circuits requiring remote pilot actuation.

OPERATION

In neutral (unpiloted), the **PD16-45** allows flow from ③ to ② bidirectionally. The spring chamber is directed to port ④.

On remote pilot signal at ①, the valve shifts to block from ③ to ②, bidirectionally.

Since ④ is common to the spring chamber, pressure on ④ will directly (1:1) affect the pilot pressure required, and must always be added to the bias spring value.

FEATURES

- Hardened spool and cage for long life.
- Optional sealed pilot.
- Industry common cavity.

RATINGS

Operating Pressure: 240 bar (3500 psi)

Flow: See Performance Chart

Internal Leakage: 164 cc/minute (10 cu. in./minute) max. at 207 bar (3000 psi)

Pilot Pressure Required:

To Spool Crossover: 7.6 bar (110 psi)

To Full Spool Shift: 9.0 bar (130 psi)

Oil Volume Required to Full Shift: 2.5 cc (0.15 cu. in.)

Temperature: -40 to 120°C with standard Buna seals

Filtration: See page 9.010.1

Fluids: Mineral-based or synthetics with lubricating properties at viscosities of 7.4 to 420 cSt (50 to 2000 sus); See Temperature and Oil Viscosity, page 9.060.1

Installation: No restrictions; See page 9.020.1

Cavity: VC16-4; See page 9.116.1

Cavity Tool: CT16-4XX; See page 8.600.1

Seal Kit: SK16-4X-MMM; See page 8.650.1

SYMBOLS

USASI:

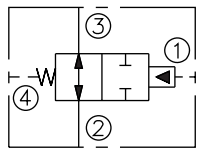

ISO:

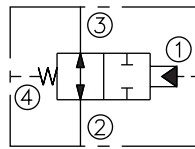

PERFORMANCE (Cartridge Only)

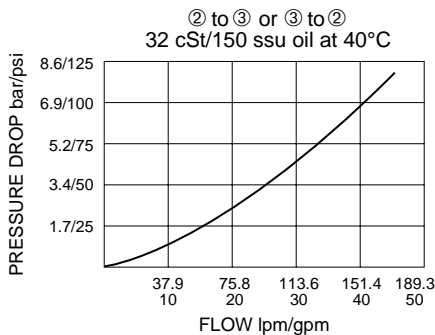

DIMENSIONS

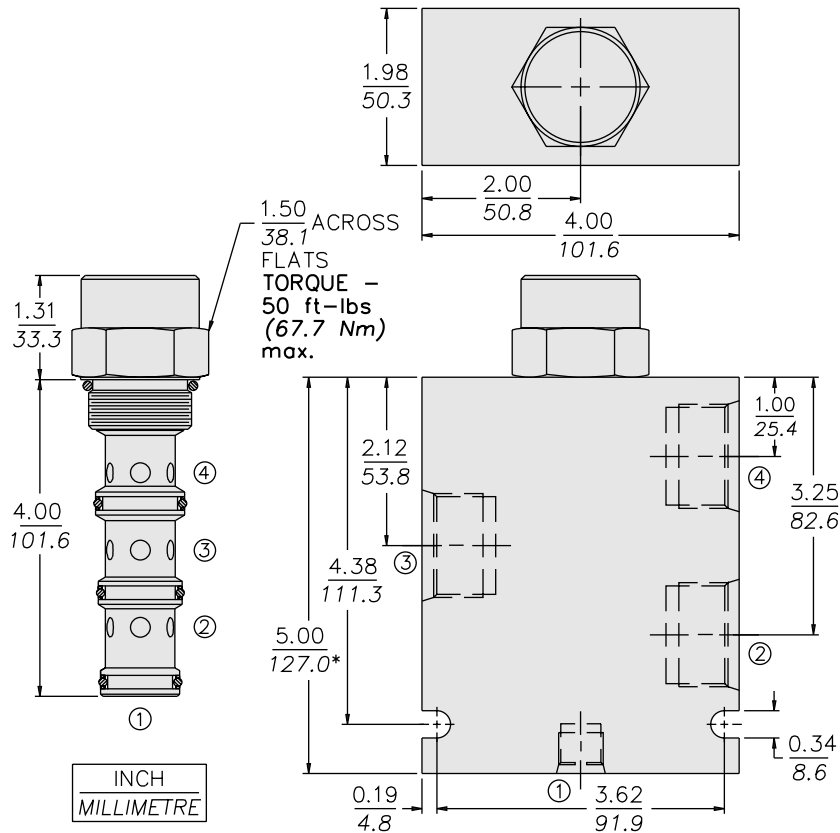

* BSP BODY - 134.9

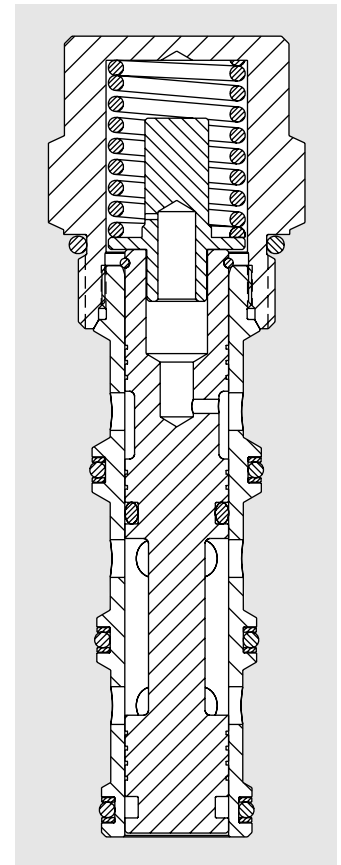

MATERIALS

Cartridge: Weight: 0.52 kg. (1.15 lbs.)
Steel with hardened work surfaces.
Zinc-plated exposed surfaces.
Buna N O-rings and polyester elastomer back-ups standard.

Standard Ported Body: Weight: 1.5 kg. (3.3 lbs.) Anodized high-strength 6061 T6 aluminum alloy, rated to 207 bar (3000 psi). Ductile iron bodies available; dimensions may differ. See page 8.016.1.

TO ORDER

PD16-45 -

Porting
Cartridge Only **0**
SAE 12, SAE 6 Pilot **12T**
SAE 16, SAE 6 Pilot **16T**

Bias Spring†

60 4.1 bar (60 psi)
110 7.6 bar (110 psi)
170 11.7 bar (170 psi)

Optional bias springs considered on OEM request.

†Note: 110 psi bias spring is the minimum required for use with sealed spool.

Seals

N Buna N (Std.)
NS Buna N with Sealed Spool
V Fluorocarbon
VS Fluorocarbon with Sealed Spool