

PD16-S50 Piloted 3-Way Spool

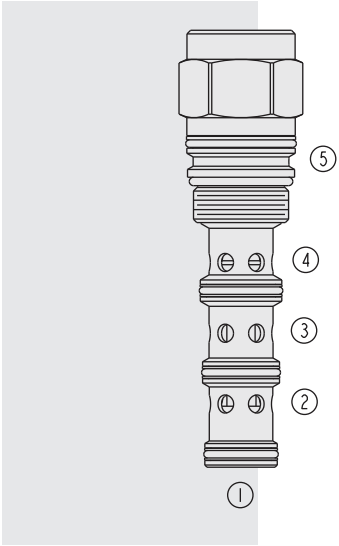

DESCRIPTION

A screw-in, cartridge-style, pilot-operated, spool-type, hydraulic directional valve.

OPERATION

When in neutral the **PD16-S50** allows flow between ports 3 and 2 while blocking at 4. On remote pilot signal at 1, the valve's spool shifts to allow flow between 3 and 4, while blocking at 5. The spring chamber is vented to the tank through port 5. The vented spring chamber allows the valve to be fully pressurized at ports 1, 2, 3, and 4 without affecting required pilot pressure. Pressure at port 5 will affect required pilot pressure.

FEATURES

- Hardened spool and cage for long life.
- 50, 70, 100 and 150 psi bias springs available.

RATINGS

Operating Pressure: 240 bar (3500 psi)

Flow: 0–170 lpm (0–45 gpm); See Performance Chart

Internal Leakage at 207 bar (3000 psi): 245 ml/minute (15 cu. in./minute);
Zero leakage from port 1 to port 2 with sealed spool.

Temperature: -40 to 120°C

Filtration: See page 9.010.1

Fluids: Mineral-based or synthetics with lubricating properties at viscosities of 7.4 to 420 cSt (50 to 2000 sus); See Temperature and Oil Viscosity, page 9.060.1

Installation: No restrictions; See page 9.020.1 A 6-way body can be used for this valve by plugging body port 2 and using body ports 3, 4, 5 and 6 as ports 2, 3, 4 and 5 for the valve.

Cavity: VC16-S5; See page 9.116.1

Cavity Tool: CT16-S5XX; See page 8.600.1

Seal Kit: SK16-S5X-BMMM; See page 8.650.1

SYMBOLS

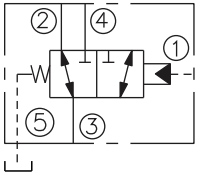

Open Transition Option:

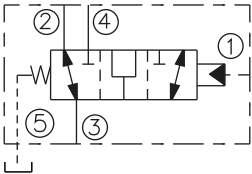

PERFORMANCE (Cartridge Only)

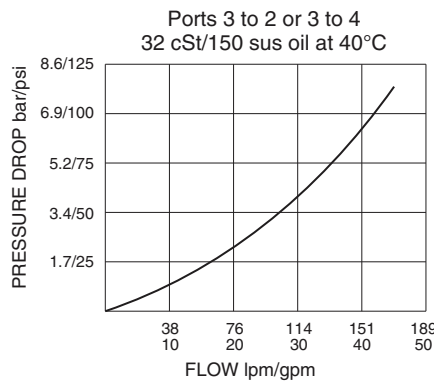

DIMENSIONS

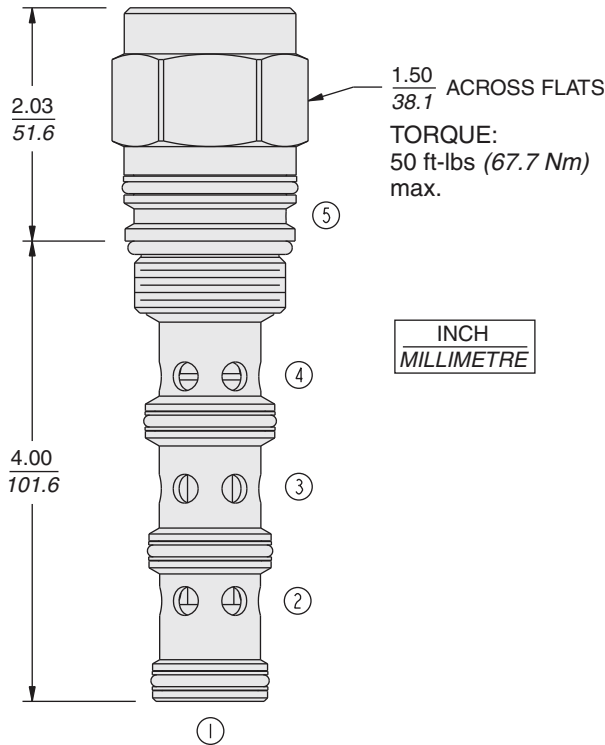

MATERIALS

Cartridge: Weight: 0.68 kg. (1.50 lbs.)
Steel with hardened work surfaces.
Zinc-plated exposed surfaces.
Buna N O-rings and polyester elastomer back-ups standard.

Ported Body: Consult factory. A 6-way body can be used for this valve by plugging body port 2 and using body ports 3, 4, 5 and 6 as ports 2, 3, 4 and 5 for the valve.

TO ORDER

