

PD12-S60N Piloted, 2-Position, 4-Way Spool

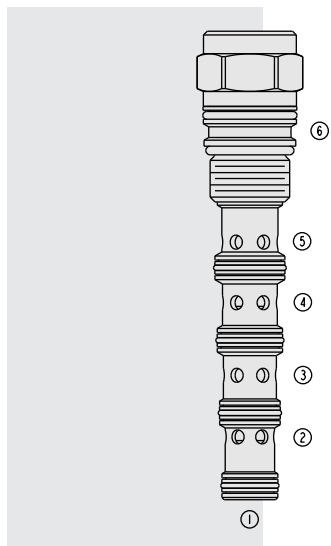

DESCRIPTION

A screw-in, cartridge-style, pilot-operated, 2-position, 4-way, spool-type, hydraulic directional valve.

OPERATION

In the neutral position, the **PD12-S60N** allows flow between ports ② and ③ and between ports ④ and ⑤. On remote pilot signal at ①, the valve shifts to allow flow between ports ③ and ④, and between ports ② and ⑤.

The spring chamber is vented to the tank through port ⑥. The vented spring chamber allows the valve to be fully pressurized at ports ①, ②, ③, ④ and ⑤ without affecting required pilot pressure. Pressure at ⑥ will affect required pilot pressure.

FEATURES

- Hardened spool and cage for long life.
- Up to 344 bar (5000 psi) operation.
- 110 and 170 psi bias springs available.

RATINGS

Maximum Operating Pressure: With Polyurethane Seals: 344 bar (5000 psi)

Flow: 0 to 56 lpm (0 to 15 gpm); See Performance Chart

Internal Leakage: Maximum leakage at 240 bar (3500 psi):
197 ml/minute (12 cu. in./minute).

Temperature: -40 to 120°C (-40 to 248°F)

Filtration: See page 9.010.1

Fluids: Mineral-based or synthetics with lubricating properties at viscosities of
7.4 to 420 cSt (50 to 2000 sus); See Temperature and Oil Viscosity, page 9.060.1

Installation: No restrictions; See page 9.020.1

Cavity: VC12-S6; See page 9.112.1

Cavity Tool: CT12-S6XX; See page 8.600.1

Seal Kit: SK12-S6X-BMMMM; See page 8.650.1

SYMBOLS

USASI:

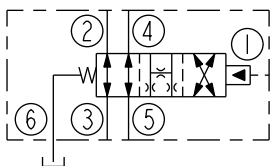

ISO:

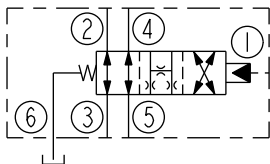

PERFORMANCE (Cartridge Only)

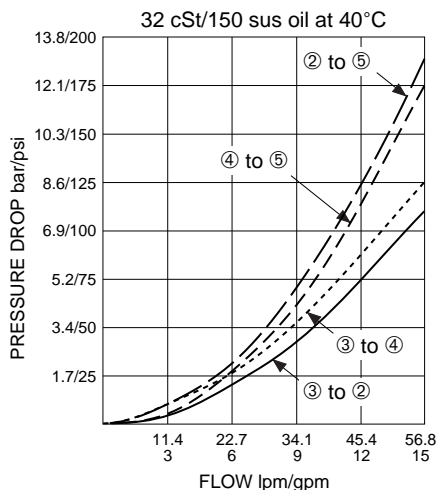

DIMENSIONS

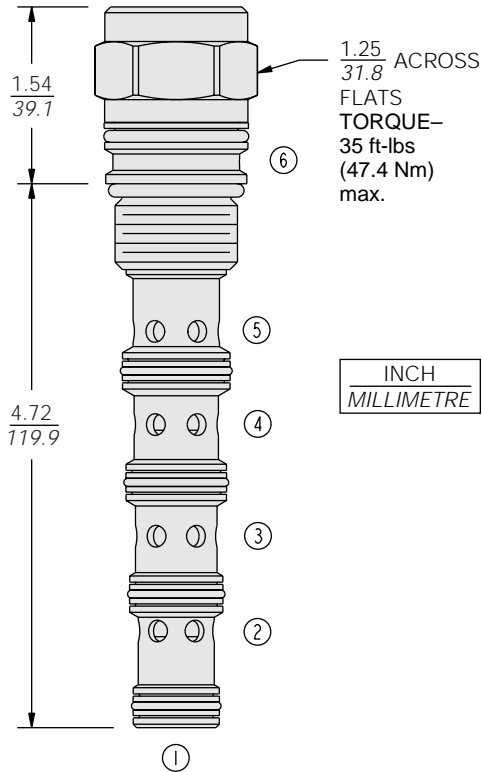

MATERIALS

Cartridge: Weight: 0.21 kg. (0.46 lbs.)
 Steel with hardened work surfaces.
 Zinc-plated exposed surfaces.
 Buna N O-rings and polyester elastomer back-ups standard.

Ported Body: Test housing available; see page 8.012.1.

TO ORDER

PD12-S60N-

Porting
 Cartridge Only 0

Bias Spring
 110 7.6 bar (110 psi)
 170 11.7 bar (170 psi)

Seals
N Buna N (Std.)
NS Buna N with Sealed Spool between ① and ②
V Fluorocarbon
VS Fluorocarbon with Sealed Spool between ① and ②
P Polyurethane*
PS Polyurethane with Sealed Spool between ① and ②*

*Required for pressures over 3500 psi