

HEP42-S39 HyPerformance™ Vented Poppet-type

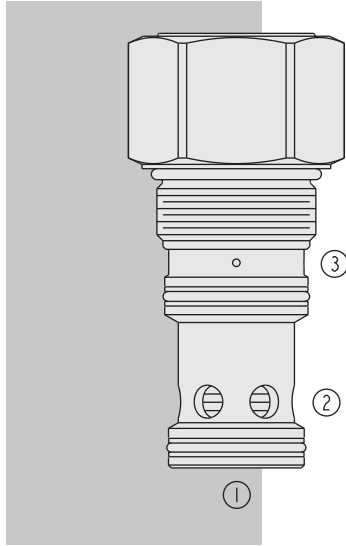

DESCRIPTION

A high pressure, poppet-type, screw-in, cartridge-style, spring-biased, bi-directional blocking-type hydraulic valve with two built-in checks. When used in conjunction with a small pilot solenoid valve, the HEP42-S39 is ideal for either high-flow double-blocking circuits or selector circuits. The integral two-check system prevents leakage, maintaining the pilot signal regardless of the transition or the work-port pressure changes.

OPERATION

The HEP42-S39 will allow flow from 1 to 2 or 2 to 1 only when 3 is vented to create a pressure differential across the internal orifice which exceeds the pressure value of the bias spring. When the element is in the neutral (closed) state, the ratio of areas 1 and 2 is 1:1, and the ratio of areas 1 or 2 to 3 is 1:2.

FEATURES

- Multiple function/application potential.
- Low pressure drop.
- All HyPerformance products are tested to the rigorous standards of the NFPA specification T2.6.1.
- All HyPerformance valves are tested at a verification level of 90% and an assurance of 99%.

RATINGS

Operating Pressure: 350 bar (5075 psi); 10% cycle life: 420 bar (6090 psi)

Note: All HyPerformance products are tested for 900K cycles at 350 bar and 100K at 420 bar.

Proof Pressure: 690 bar (10000 psi)

Burst Pressure: 1380 bar (20000 psi)

Flow: 284 lpm (75 gpm)

Internal Leakage: 12 drops per minute max. at 350 bar (5075 psi)

Operating Temperature: -54 to 107°C (-65 to 225°F) with Urethane seals

Filtration: See page 9.010.1

Fluids: Mineral-based or synthetics with lubricating properties at viscosities of 7.4 to 420 cSt (50 to 2000 sus); See Temperature and Oil Viscosity, page 9.060.1

Installation: No restrictions; See page 9.020.1

Cavity: HVC42-S3; See page 9.142.1

Cavity Tool: HCT42-S3XX; See page 8.600.1

Seal Kit: SK42-S3X-MM; See page 8.650.1

SYMBOLS

USASI/ISO:

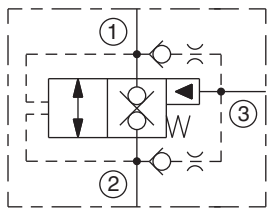

PERFORMANCE (Cartridge Only)

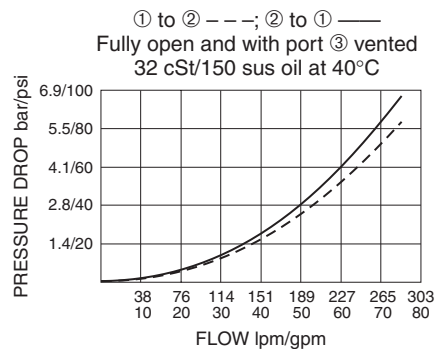

Logic Element w/Built-in Checks

HEP42-S39

DIMENSIONS

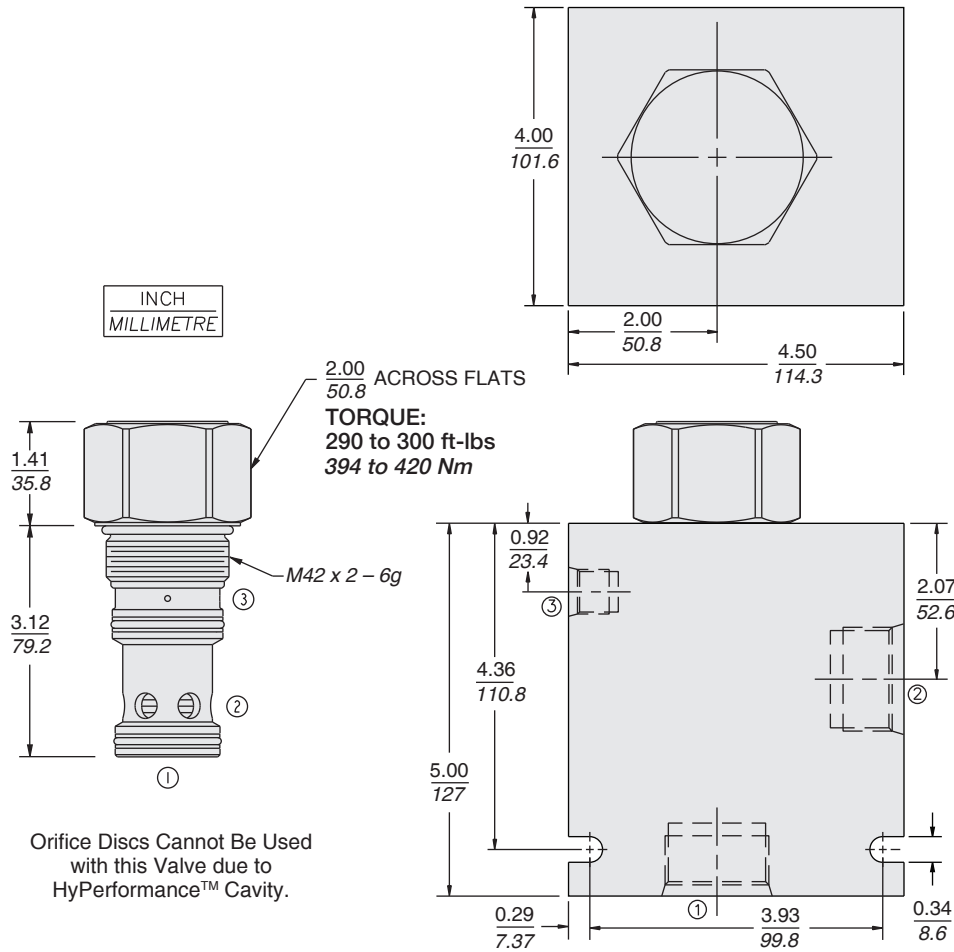

MATERIALS

Cartridge: Weight: 1.04 kg. (2.30 lbs.)
Steel with hardened work surfaces.
Zinc-nickel plated exposed surfaces.
PPDI Urethane seals with no backup rings standard.

Ported Body: Weight: 9.03 kg. (19.9 lbs.); HyPerformance™
Ductile iron (code 'D') standard.
Rated to 345 bar (5000 psi).

TO ORDER

HEP42-S39 - - - 160

Porting
Cartridge Only 0
SAE 20 20TD
1-1/4 in. BSP* 10BD
*BSP Body; U.K. Mfr. Only

Bias Spring Value
160 11.0 bar (160 psi)

Seals
U PPDI Urethane — Recommended for pressures above 241 bar (3500 psi)