

MD10-40 Manual, Spring Return, Push-to-Shift

Patent Pending

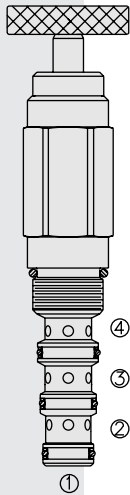

DESCRIPTION

A 4-way, manual, push-to-shift, spring-return, directional hydraulic cartridge valve. Series operation is prohibited due to the tank port (1) pressure rating.

OPERATION

In its steady-state spring-offset position, the **MD10-40** directs flow from 4 to 3, and from 2 to 1 (tank).

In the actuated (pushed) position, the cartridge directs flow from 2 to 3, and from 4 to 1. Note that all ports are open in transition.

Note: Pressure at port 1 will directly act on the spool and spring. Port 1 is intended to be a tank port only.

When the valve is actuated (pushed in) it can be detented by holding in and turning the knob clockwise 90°. When released, the valve will remain in the actuated position. To return the valve to its steady state, push in the knob and turn the handle counterclockwise.

FEATURES

- Hardened spool and cage for long life.
- Remains closed to 14 bar (200 psi) back-pressure.
- Optional rotational lock position.
- Industry common cavity.

RATINGS

Operating Pressure:

- On 2, 3 and 4: 207 bar (3000 psi)
- On 1 (Max.): 14 bar (200 psi)

Cycle Life: 100,000

Flow: See Performance Chart

Internal Leakage: 82 cc/minute (5 cu. in./minute) max.

Temperature: -40 to 120°C

Filtration: See page 9.010.1

Fluids: Mineral-based or synthetics with lubricating properties at viscosities of 7.4 to 420 cSt (50 to 2000 sus); See Temperature and Oil Viscosity, page 9.060.1

Installation: No restrictions; See page 9.020.1

Cavity: VC10-4; See page 9.110.1

Cavity Tool: CT10-4XX; See page 8.600.1

Seal Kit: SK10-4X-MMT; See page 8.650.1

SYMBOLS

USASI/ISO:

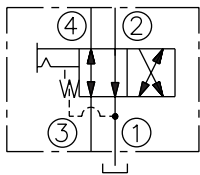

PERFORMANCE (Cartridge Only)

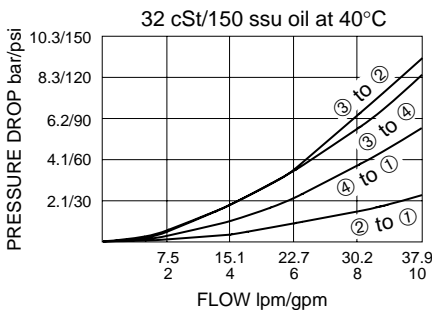

DIMENSIONS

Patent Pending

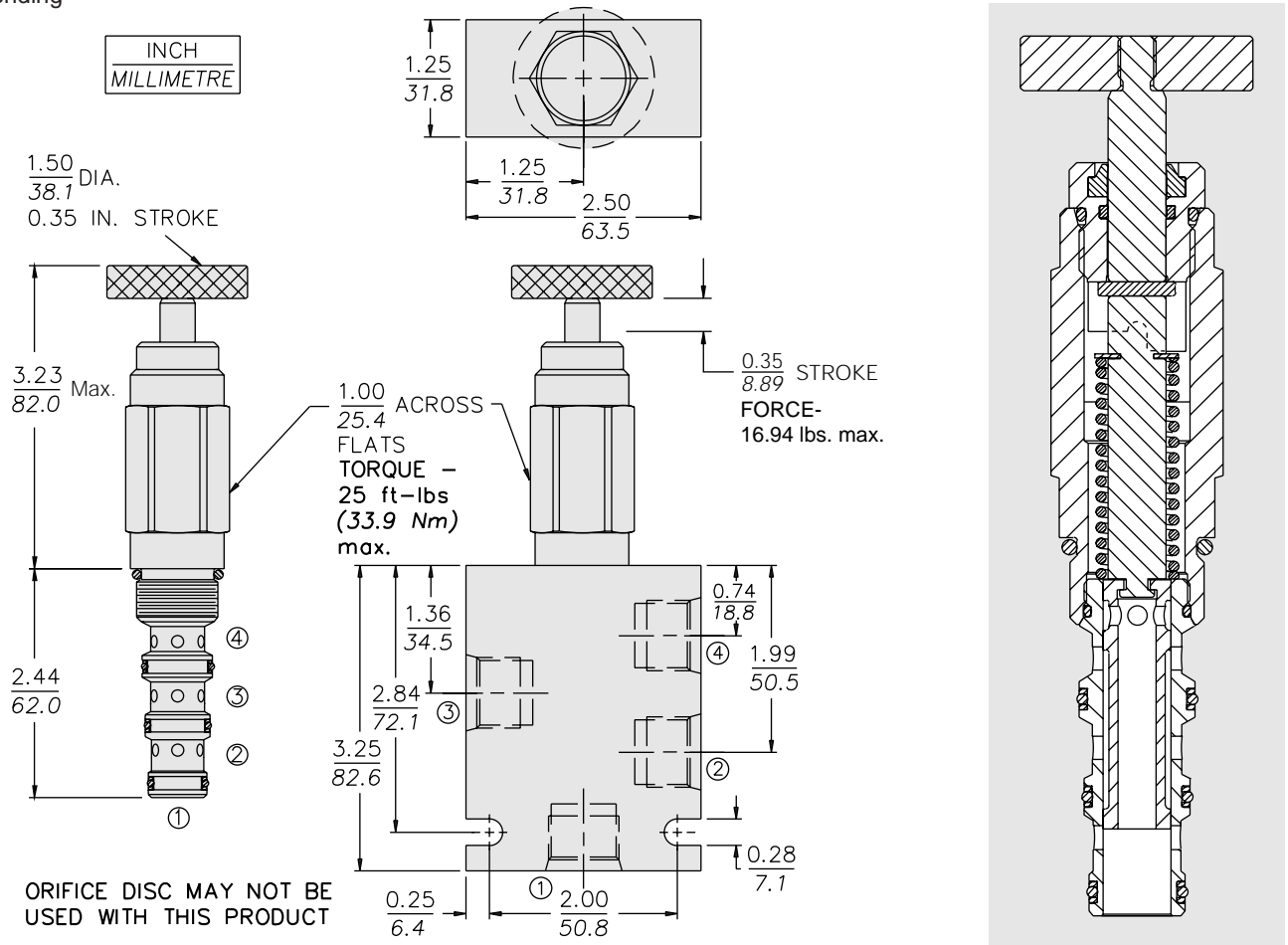

MATERIALS

Cartridge: Weight: 0.32 kg. (0.70 lbs.)
Steel with hardened work surfaces.
Zinc-plated exposed surfaces.
Buna N O-rings and polyester elastomer back-ups standard.
Aluminum knob.

Standard Ported Body: Weight: 0.34 kg. (0.75 lbs.) Anodized high-strength 6061 T6 aluminum alloy, rated to 207 bar (3000 psi). Ductile iron bodies available; dimensions may differ. See page 8.010.1

TO ORDER

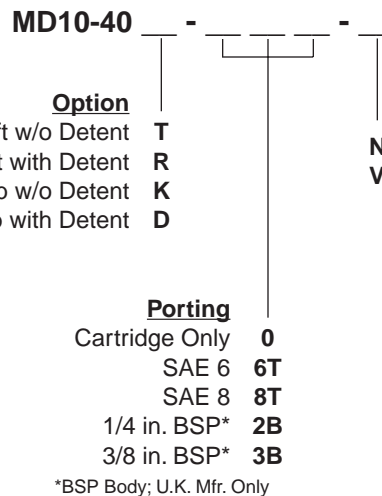

Seals

- N** Buna N (Std.)
- V** Fluorocarbon