

MR10-43 Manual Rotary 4-Way, 2-Pos. Directional Valve

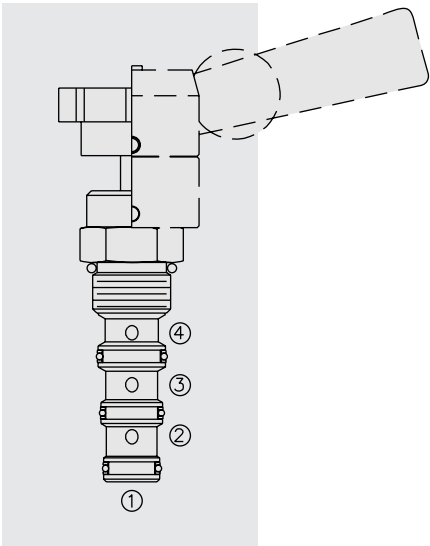

DESCRIPTION

A manually-operated four-way, two-position directional valve, with adaptability to a variety of adjustment operators (ordered separately).

OPERATION

Two positions, 90° rotation. In extreme counterclockwise position ports ① and ② are open while ports ③ and ④ are closed. In extreme clockwise position, ports ① and ④ are open while ports ② and ③ are open. In transition, ports ①, ② and ③ are partially open while port ④ is closed.

FEATURES

- Two-position detent or infinite friction lock may be ordered separately.
- May be fully pressurized at all ports.
- Optional lock-down bracket.
- Heavy-duty construction.
- Industry common cavity.

RATINGS

Operating Pressure: 240 bar (3500 psi)

Max. Flow: See Performance Chart

Internal Leakage: 164 cc/minute (10 cu. in./minute) at 240 bar (3500 psi)

Temperature: -40 to 120°C with standard Buna N seals

Fluids: Mineral-based or synthetics with lubricating properties at viscosities of 7.4 to 420 cSt (50 to 2000 sus); See Temperature and Oil Viscosity, page 9.060.1

Installation: No position restrictions; See page 9.020.1

See page 4.990.2 for operator handles/knobs installation;

See page 4.990.1 for lock-down bracket installation.

Cavity: VC10-4; See page 9.110.2

Cavity Tool: CT10-4XX; See page 8.600.1

Seal Kit: SK10-4X-MMM; See page 8.650.1

Lock-Down Bracket Kit: Part Number 5399000

SYMBOLS

USASI/ISO:

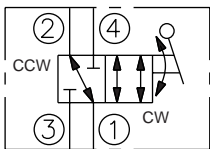

TRANSITION:

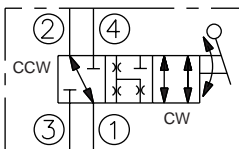

PERFORMANCE (Cartridge Only)

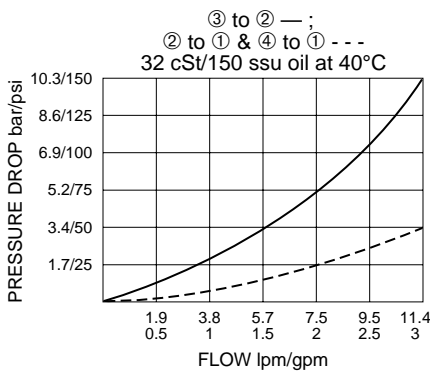

DIMENSIONS

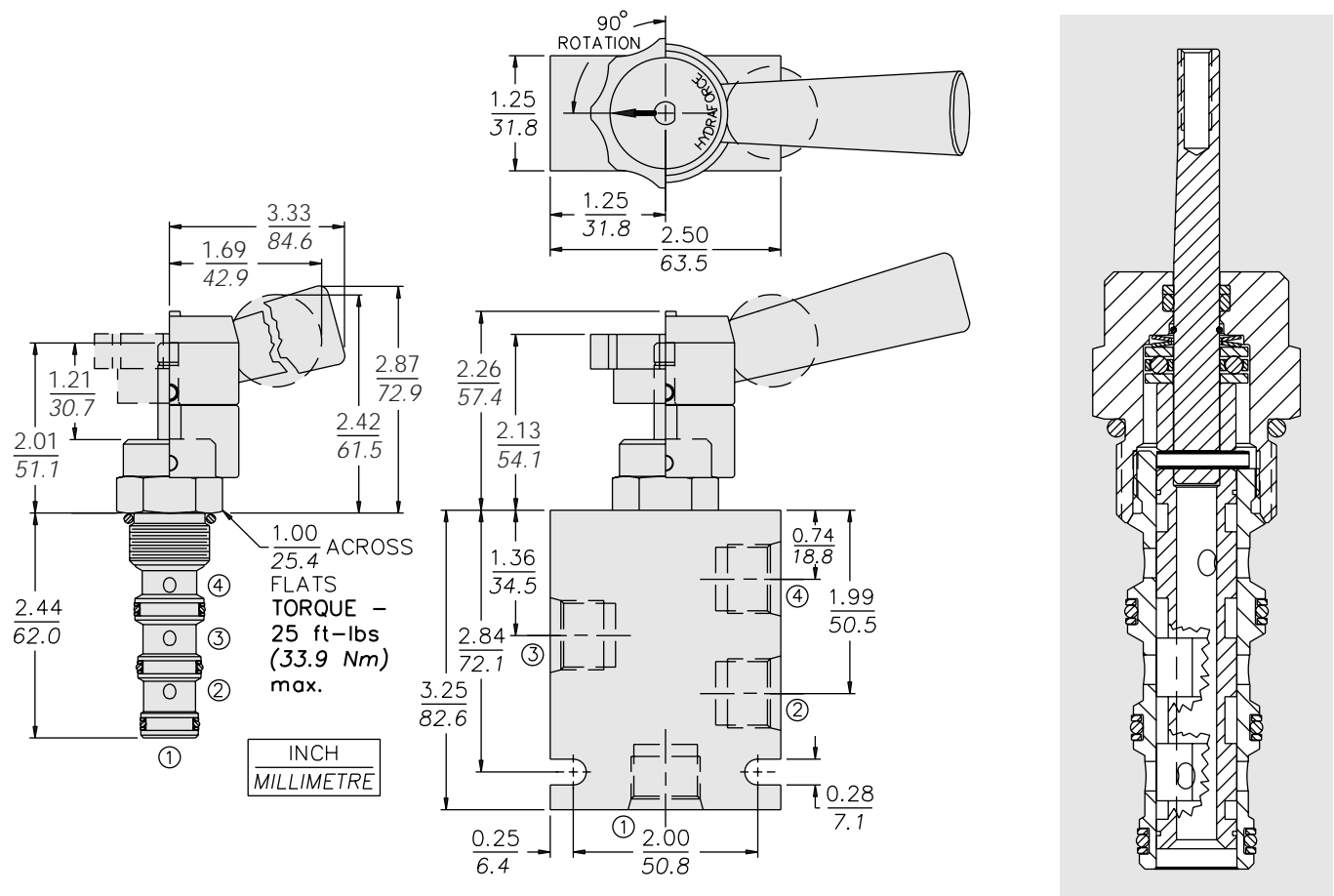

MATERIALS

Cartridge: Weight: 0.13 kg. (0.29 lbs.)
Steel with hardened work surfaces.
Zinc-plated exposed surfaces.
Buna N O-rings and Fluorocarbon
back-ups standard.

Standard Ported Body: Weight:
0.34 kg. (0.75 lbs.) Anodized high-
strength 6061 T6 aluminum alloy,
rated to 207 bar (3000 psi). Ductile
iron bodies available; dimensions
may differ. See page 8.010.1

Lever-Type Handle: (Sold Separately)
Weight: 0.18 kg. (0.38 lbs.) Steel with
hardened work surfaces. Zinc-plated
exposed surfaces. Plastic lever arm.

TO ORDER

MR10-43

Option

None (Blank)

Seals

N Buna N (Std.)
V Fluorocarbon

Porting

Cartridge Only **0**
SAE 6 **6T**
SAE 8 **8T**
SAE 8 with
Lock-Down Bracket **8TL**
1/4 in. BSP* **2B**
3/8 in. BSP* **3B**

NOTE: To order standard
operator kits, refer to pages
4.770.1 and 4.770.2

*BSP Body;
U.K. Mfr. Only