

## MR10-47F Manual Rotary, 4-Way, 3-Position

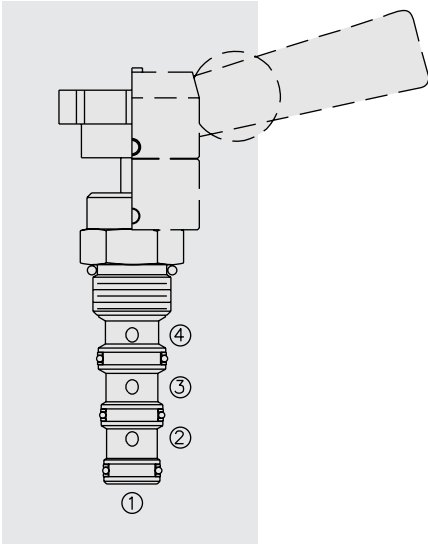

### DESCRIPTION

Manually-operated four-way, three-position directional valve, with adaptability to a variety of adjustment operators (ordered separately), in a variety of spool configurations.

### OPERATION

Three positions: centered, 45° counterclockwise, and 45° clockwise. In the center position ports ① and ③ are open while ports ② and ④ are closed. In the 45° counterclockwise from center position, ports ③ and ④ are open while ports ① and ② are open. In the 45° clockwise from center position, ports ② and ③ are open while ports ① and ④ are closed. All ports are partially open in transition, except for clockwise from center rotation when port ④ remains closed in transition.

### FEATURES

- Three-position detent, friction lock (with detented neutral), or spring return operators may be ordered separately.
- May be fully pressurized at all ports.
- Optional lock-down bracket.
- Heavy-duty construction.
- Industry common cavity.

### RATINGS

**Operating Pressure:** 240 bar (3500 psi)

**Max. Flow:** See Performance Chart

**Internal Leakage:** 164 cc/minute (10 cu. in./minute) at 240 bar (3500 psi)

**Temperature:** -40 to 120°C with standard Buna N seals

**Fluids:** Mineral-based or synthetics with lubricating properties at viscosities of 7.4 to 420 cSt (50 to 2000 sus); See Temperature and Oil Viscosity, page 9.060.1

**Installation:** No position restrictions; See page 9.020.1

See page 4.990.2 for operator handles/knobs installation;

See page 4.990.1 for lock-down bracket installation.

**Cavity:** VC10-4; See page 9.110.1

**Cavity Tool:** CT10-4XX; See page 8.600.1

**Seal Kit:** SK10-4X-MMM; See page 8.650.1

**Lock-Down Bracket Kit:** Part Number 5399000

### SYMBOLS

#### USAS/ISO:

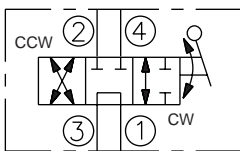

#### TRANSITION:

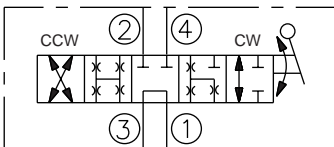

### PERFORMANCE (Cartridge Only)

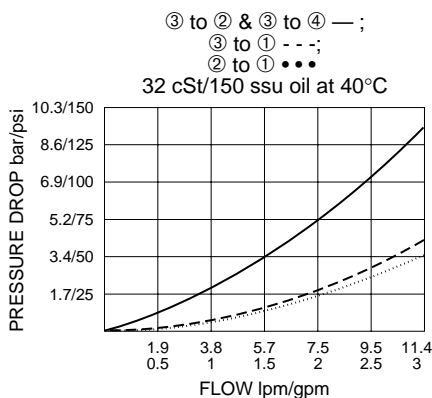

**DIMENSIONS**

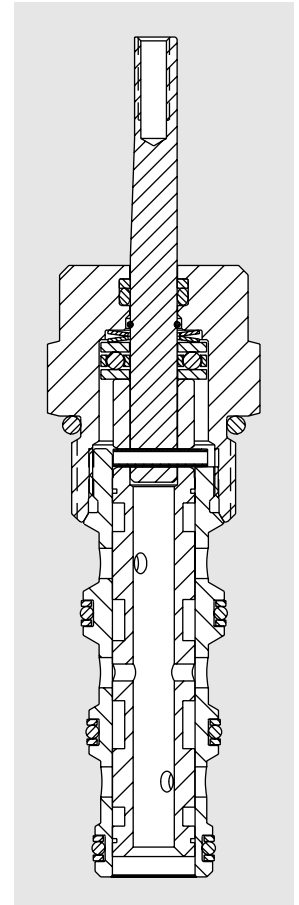
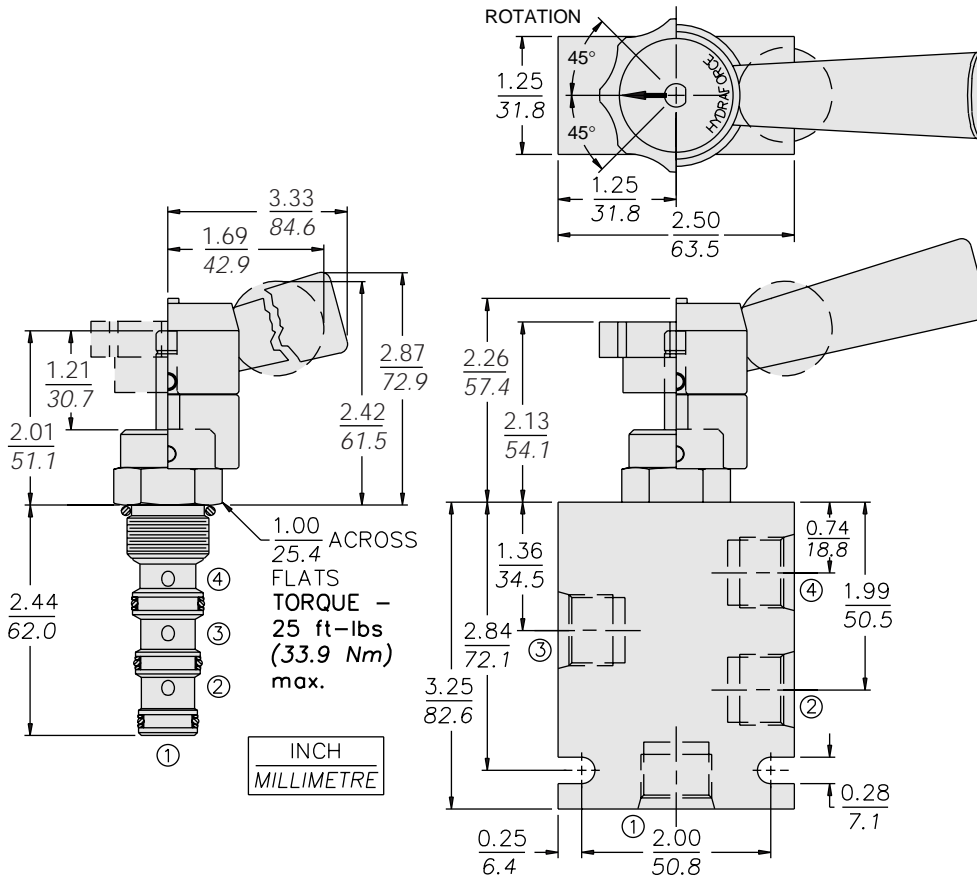

**MATERIALS**

**Cartridge:** Weight: 0.13 kg. (0.29 lbs.)  
Steel with hardened work surfaces.  
Zinc-plated exposed surfaces.  
Buna N O-rings and Fluorocarbon back-ups standard.

**Standard Ported Body:** Weight:  
0.34 kg. (0.75 lbs.) Anodized high-strength 6061 T6 aluminum alloy, rated to 207 bar (3000 psi). Ductile iron bodies available; dimensions may differ. See page 8.010.1

**Lever-Type Handle:** (Sold Separately)  
Weight: 0.18 kg. (0.38 lbs.) Steel with hardened work surfaces. Zinc-plated exposed surfaces. Plastic lever arm.

**TO ORDER**

**MR10-47F**

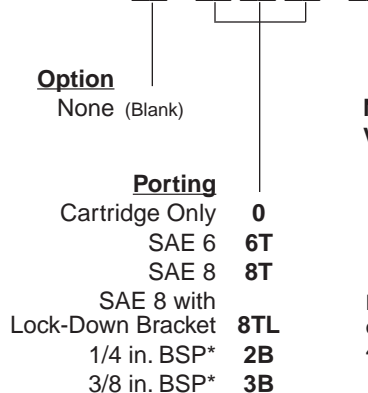

\*BSP Body;  
U.K. Mfr. Only

NOTE: To order standard operator kits, refer to pages 4.770.1 and 4.770.2