

ECU-0710 Machine Controller

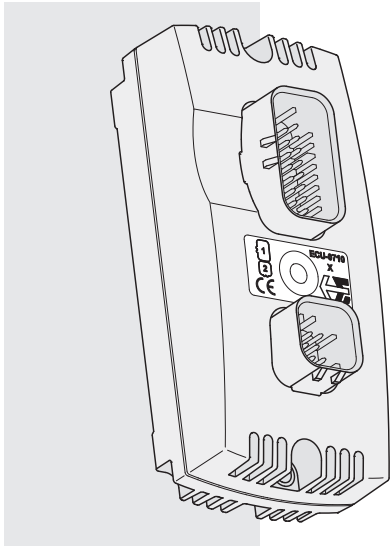

FEATURES

- Advanced electronic design for reliability and accuracy.
- Reliable operation in real-world temperature conditions from -40°C to +70°C.
- Fully-sealed, compact cast-aluminum housing.
- Inputs and Outputs are protected against shorts.
- Outputs have diagnostic capability.
- No external cooling or heat dissipation required.
- Software developed with **CoDeSys**. 2.3 Programming Tool.

DESCRIPTION

The ECU-0710 Machine Controller is a general-purpose programmable controller designed to withstand the real-world environmental demands of the off-highway mobile market. The ECU-0710 can be used as a stand-alone controller, or for integrating into a CAN network with other devices.

Input configuration can be set for up to 20 inputs consisting of Digital, Pulse, Current Measuring Feedback and Analog inputs. Output configuration can be set for a total of 7 outputs consisting of up to 6 PWM or digital high-side drivers, and a single low-side driver. All outputs are capable of driving up to 3.0 Amps.

NOTE: Refer to Input/Output table below for pin configuration capability. Refer to ECU-0710 Technical Reference Manual for specific data and ratings of individual inputs and outputs.

RATINGS

POWER REQUIREMENTS:

Operating Voltage: 9 to 30 VDC

Idle Power Consumption: approximately 1 Watt

Operating Current: 10 Amp Max. continuous current, with full external load.

Over-Voltage: 34 VDC maximum

REFERENCE VOLTAGES:

(1) 5 VDC Potentiometer Reference: 5 mA DC

COMMUNICATION:

(2) ISO CAN 2.0B Interfaces: CANopen, J1939, or user-programmable.

PROCESSING and MEMORY:

Microprocessor: 16-bit at 40 MHz

Flash ROM: 254 Kbyte

SRAM: 256 Kbyte

EEPROM: 6200 bytes

ENVIRONMENTAL RATINGS:

Operating Temperature: -40°C to +70°C

Storage Temperature: -50°C to +85°C

Water Resistance: meets IP67 standards (per IEC 660529)

Humidity Tolerance: Rel. Humidity > 90% from +25°C to +55°C (per IEC 60068-2-30 Test Db)

Radiated Immunity: 20 to 2000 MHz at 30 V/m (per 2005/83/EC Annex IX)

Vibration: 3.5Grms random from 10 to 500 Hz (per IEC 60068-2-64 Test Fh)

Shock: 50g peak (per IEC 60068-2-27 and -29 Tests Ea and Eb)

Corrosion: 50 g/l, NaCl for 24 hours at +35°C (per ISO 9227)

INPUTS / OUTPUTS — 20 Total

Max. I/O Count	Digital In (SWG)	Digital In (SWB)	Pulse Input	Analog Input	Current Feedback	PWM (Source)	Digital Out (Source)	Digital Out (Sink)
6		X				X	X	
2	X		X					
2		X	X					
3					X			
6		X		X				
1		X						X
20	2	15	4	6	3	6	6	1

Note: The ECU-0710 has inputs and outputs that can be configured in multiple ways. For more information, consult the ECU-0710 Technical Reference Manual.

ECU-0710 Machine Controller

DIMENSIONS and MOUNTING

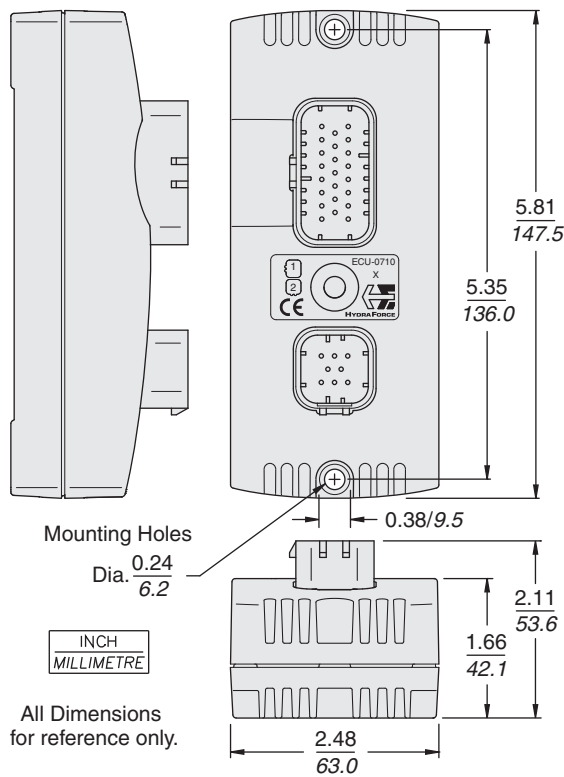

Weight: 1.11 lbs./**0.5 kg**

Mounting on Horizontal Surface:

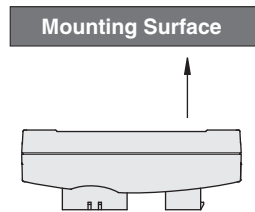

Mounting on Vertical Surface:

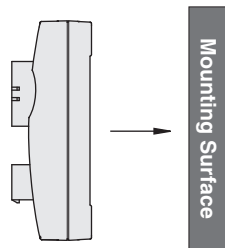

The mounting positions shown here will allow water or other potential contaminants to fall away from connectors.

Allow 5 in./**125 mm** clearance from mounting surface for connector installation.

For additional mounting information, consult the ECU-0710 Technical Reference Manual.

TO ORDER

Controller: Model **ECU-0710** Part No. 4000351

AmpSeal Connectors: 23-Pin Grey Part No. 4000361; 8-Pin Black Part No. 4000363

AmpSeal Socket/Plug: Sockets Gold (100 pc.) Part No. 4000369; Sealing Plugs (100 pc.) Part No. 4000370

Shock Cover Kit (optional): Part No. 4206820

CoDeSys Programming Software: available from 3S Software GmbH

USB-CAN Adaptor: Part No. 4000371, also available from www.kvaser.com/prod/hardware/leaf_light.htm

Diagnostic Kit: Part No. 4000372

Start-Up Kit: Part No. 4209060 Start-Up Kit includes the ECU-0710 controller, 8-pin power connector, 23-pin I/O connector, connector sockets and USB-CAN adaptor.

PIN ASSIGNMENTS

Pin	Connector 1 Pin Function	Type
1	Digital Input/PWM Output/Digital Output	I/O
2	Current Measuring Feedback	FB
3	Digital Input/PWM Output/Digital Output	I/O
4	Digital Input/PWM Output/Digital Output	I/O
5	Current Measuring Feedback	FB
6	Current Measuring Feedback	FB
7	Digital Input/PWM Output/Digital Output	I/O
8	Digital Input/PWM Output/Digital Output	I/O
9	Digital Input/PWM Output/Digital Output	I/O
10	Digital Input/Analog Input	Input
11	Digital Input/Pulse Input, 2.2KΩ to +5VDC	Input
12	Digital Input/Pulse Input, 2.2KΩ to +5VDC	Input
13	Digital Input/Pulse Input, 10KΩ to GND	Input
14	Digital Input/Pulse Input, 10KΩ to GND	Input
15	Must be left open	N/A
16	+5 VDC Reference (Ref 47Ω)	—
17	Digital Input/Analog Input	Input
18	Digital Input/Digital Output	I/O
19	Ground (Ref 47Ω)	—
20	Digital Input/Analog Input	Input
21	Digital Input/Analog Input	Input
22	Digital Input/Analog Input	Input
23	Digital Input/Analog Input	Input

Pin	Connector 2 Pin Function	Type
1	Power Ground	—
2	CAN 1 HIGH	I/O
3	Power Ground	—
4	V _{SUPPLY} (+9 to 30 VDC)	—
5	V _{SUPPLY} (+9 to 30 VDC)	—
6	CAN 1 LOW	I/O
7	CAN 2 HIGH	I/O
8	CAN 2 LOW	I/O