



HYDRAFORCE ELECTRONICS

ECU REQUIREMENTS OUTLINE

Table of Contents

1	ECU Machine Controllers	2
2	Development and Application Process	2
3	ECU Connectors	4
4	Mounting Hardware	6
5	Material Requirements	6



1 ECU Machine Controllers

Products Included:	ECU-MS	25 Inputs / 8 PWM Outputs and 4 On/Off Drivers
	ECU-MM	44 Inputs / 8 PWM Outputs and 12 On/Off Drivers
	ECU-ML	72 Inputs / 12 PWM Outputs with 14 On/Off Drivers

The ECU controllers are programmable, multi-function, robust processors that can relate specific or multiple inputs to a specific output for total machine control. Logic capabilities are available and used to regulate feedback loops and to program input and output relationships between sensors, displays, joysticks, and other system devices.

Programming: The software used for the HydraForce ECU system is licensed and copyright protected by Caterpillar Electronics.

- 1) Caterpillar Composer Software Engineer® (4100001) is a complete software package which includes program development as well as diagnostic capabilities. Service Technician capabilities as described below are included.
- 2) Caterpillar Composer Service Technician® (4100007) is a stand-alone, internet accessed, diagnostics program which allows limited adjustment of predetermined service parameters, real-time monitoring of service points and the ability to access the machine diagnostic log. This is intended for field or dealer set-up and adjustment.



Caterpillar Composer Software is not compatible with MS Vista® Operating Systems.

Software Training: Training in the usage of the Caterpillar Composer Software Engineer® tool generally takes between 3 and 5 days of hands-on guidance and practice.

- The software uses a logic based, function-block diagram interface. No special programming language is required, however, users should be experienced in system configuration and engineering.
- Training is conducted at HydraForce facilities, or on-site in some instances. Please contact your HydraForce representative.

2 Development and Application Process

- 1) Define and document customer requirements.
 - a. Describe vehicle functions and corresponding operator inputs
 - b. Define logic and safety requirements
 - c. Define operator controls i.e. joysticks, push buttons, potentiometers, etc.
 - d. Define feedback devices i.e. sensors
 - e. Define outputs – hydraulic circuit, displays, horns, lights, etc.
 - f. Define set-up adjustments and data records for trouble shooting (What parameters should be dealer or factory adjustable?)



HYDRAFORCE ELECTRONICS

2) Who will do the programming?

a. HydraForce, distributor or customer?

- i. If distributor or customer programming is intended, contact your HydraForce representative for training and applications engineering support.
- ii. If HydraForce will do the programming, prepare PPDE form to document operating requirements.
 1. Preliminary software development costs, bill-of-material, and a timeline will be provided based on the PPDE input.
 2. Following finalization of the project definition, HydraForce engineering will prepare an engineering specification document which will detail the requirements and expectations of the system and will guide software development. System development begins with customer sign-off and proposal approval.

3) Controllers and Communications Adapter

a. Controllers

- i. ECU-MS (4000864* unflashed)
- ii. ECU-MM (4000995* unflashed)
- iii. ECU-ML (4000997* unflashed)



Unflashed ECU's listed in the parts list receive standard product discounts and can be added to distributor stock orders.

ECU's which are flashed by HydraForce receive a unique part number and are priced with the price adder as referenced in the price list. Flashed ECU's receive quantity based line item discounts.

b. CAN Communications Adapter (4000805)

- i. 4000805 is a compact, non-sealed adapter with serial & USB connection capability.

c. Female End Connector (4002124)

- i. The communication adapters mating connector is model HD-9-96P, 9-pin Deutsch connector.

4) Caterpillar Composer Software Engineer® (4100001)

- a. Caterpillar Composer Software Engineer® is licensed by Caterpillar Electronics and is accessed via the internet.



Orders must be placed on a separate purchase order with no other product listed.

For license activation, the order must include the e-mail address of the authorized user.

The e-mail address must include the domain name of the company.

No public domain names such as Yahoo.com, Comcast.com, etc. are allowed.



HYDRAFORCE ELECTRONICS

- b. The order will be authorized by HydraForce and submitted to Caterpillar Electronics for approval, registration and processing. Lead-time is 2-weeks.
- c. The authorized user will be contacted at the referenced e-mail address with access instructions and password information. HydraForce applications engineering can assist in the set-up process.
- d. Caterpillar and / or HydraForce may choose to limit access to electronic products and software for commercial, security or safety reasons.



The Annual Software Maintenance Fee is charged separately each March following the first 12 months which is included in the software license.

The part number for the Annual Maintenance Fee is 4100024.

3 ECU Connectors

The ECU connector allows the connection of the vehicle wiring harness to the ECU. The connector is the ending termination of the wiring harness allowing for easy installation and proper pin connection.

Deutsch size 16 socket terminals (0462-201-16141) are sold separately as HydraForce number 4002063. Sealing plugs are also available for unused connector cavities (Deutsch 114017) HydraForce 6110276.

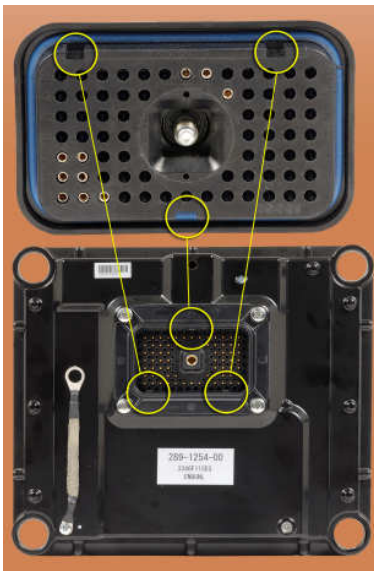

Connector:
MS (Type A) p/n: 4000750

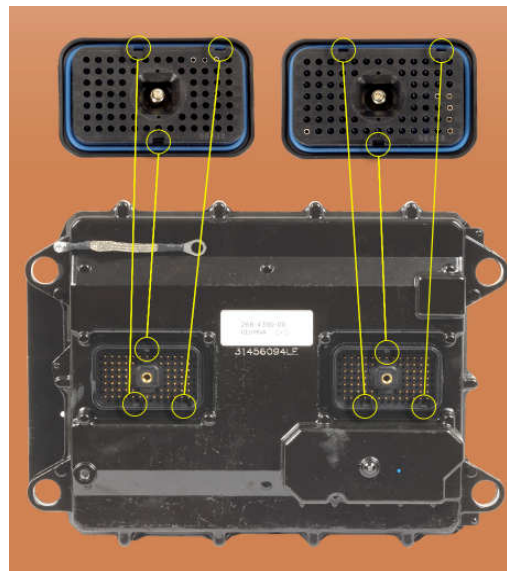

Connectors:
MM/ML (L) J1 p/n: 4000980
(R) J2 p/n: 4000979

Accommodates 14 – 18 Gauge Wiring (AWG)
Rated 13 amps per connector

2) CAN-Bus Bridge

The CAN-Bus consists of a 3-wire set which connects all input and output devices to a common communications network. In order to splice individual devices into the common network a bridge connection must be created for each device. This bridge consists of the following items which are supplied by Deutsch;

- i. Y-Splitter DT04-3P P007 (4001917)
- ii. Terminating 120Ω Resistor DT06-3S-PP01 (4001918)
- iii. Connector DT06-3S (4001952)

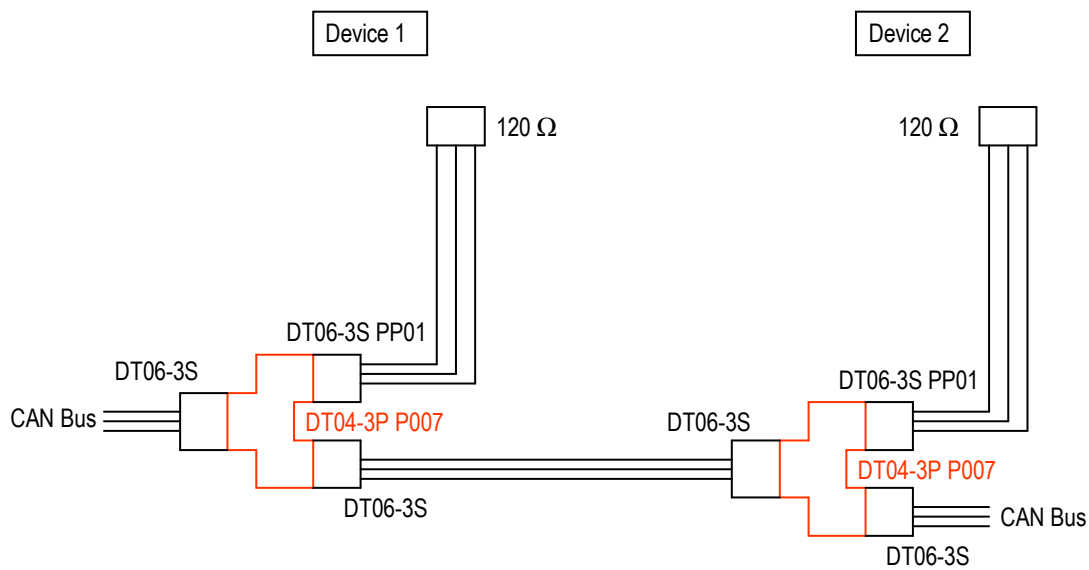

3) Power Connection / Key Switch

The ECU is designed to operate on mobile machinery with a keyed start switch. The key switch is a required input in order to operate and program the ECU. The key switch is connected in the power supply connection.

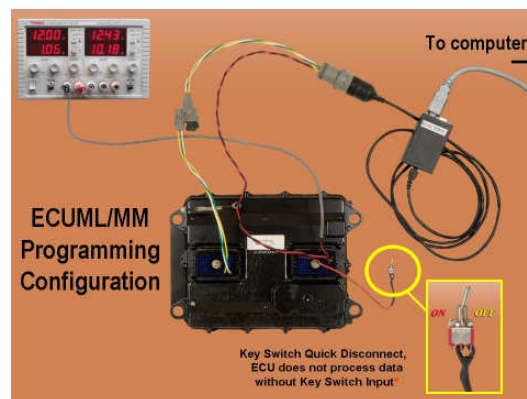
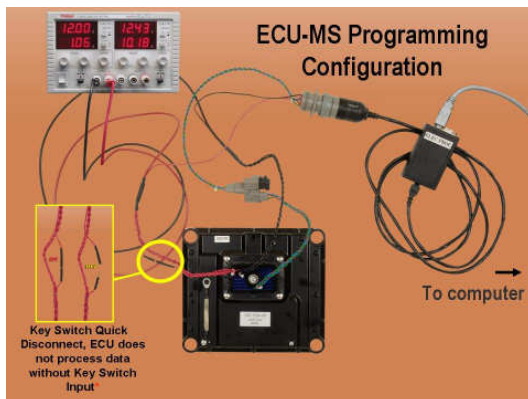



HYDRAFORCE ELECTRONICS

4 Mounting Hardware

Mounting Kit 4001629 includes washers, bushings and spacers required for the mounting of the ECU. This provides partial isolation against machine vibration. The 5/16" or M8 customer supplier bolt is also required (torque 21 ft-lb (28 N-m)).

5 Material Requirements

Qty 1 4100001 Cat Composer Software Engineer (on separate PO)

ECU-MS

Qty 1	4000864	ECU-MS
Qty 1	4000750	ECU 70-pin Connector
	4002063	Deutsch Socket (0462-201-1631)
	6110276	Deutsch Sealing Plugs (114017)

ECU-MM/ML

Qty 1	4000995	ECU-MM
or	4000997	ECU-ML
Qty 1	4000979	ECU 70-pin Connector
Qty 1	4000980	ECU 70-pin Connector
	4002063	Deutsch Socket (0462-201-1631)
	6110276	Deutsch Sealing Plugs (114017)

Installation and Test Hardware

Qty 1	4000805	Communications Adapter
Qty 1	4002124	Female End Connector
Qty 1	4001629	Mounting Kit
Qty 1	4001917	Deutsch DT04-3P P007 Y-Splitter
Qty 1	4001918	Deutsch DT06-3S-PP01 Resistor
Qty 2	4001952	Deutsch DT06-3S Connector
Qty 1	Customer	On/Off Key Switch
Qty 1	Customer	Power Supply

Change and Revision Notice:

22 January, 2009 -Applicable discount notes added to ECU description

17 February, 2009 -Deutsch Connectors corrected