

# Heavy-Duty Pressure Sensor

Model ERP345-RM-IM-06

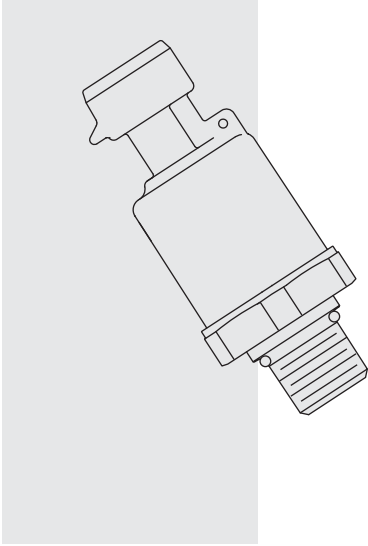

## DESCRIPTION

A high-accuracy heavy-duty pressure sensor with 1% total error band accuracy accomplished by marrying a high performance ASIC to a very stable, field-proven polysilicon, thin-film pressure sensor. This sensor is intended for use in demanding industrial and off-highway equipment.

## FEATURES

- Advanced ASIC technology for reliability and accuracy.
- 1% total error band accuracy within -20 to 85°C temperature range.
- Long term active stability and repeatability.
- Broad temperature capability.
- All-welded pressure construction.
- Protected against EMI/RFI.
- IP67 ingress rated.
- Diagnostic rails.

## RATINGS

### PERFORMANCE:

#### Pressure Range:

0 to 345 bar (0 to 5000 psi)  
For alternate pressure ranges, consult factory.

#### Durability:

Tested to 50 million cycles  
**Overpressure Limit:** 0 to 345 bar (0 to 5000 psi) range.

**Proof Pressure:** 150% Full Scale, up to 10% intermittent duty cycle.

**Burst Pressure:** 500% Full Scale.

#### Accuracy:

±1% of Span from -20 to 85°C  
±1.5% of Span from -40 to -20°C  
±1.5% of Span from 85 to 125°C  
**Static Accuracy Class:** ±0.25% of span (BFSL Method) including linearity, hysteresis, non-repeatability at reference temperature 21°C/72°F.

#### Response Time:

< 1 ms

#### Supply Voltage:

5VDC

#### Supply Current:

3.5mA

#### Radiometric Output:

0.5–4.5VDC

#### Reverse Polarity

and Miswired Protected

## INSTALLATION & PHYSICAL SPECIFICATIONS

**Electrical Connection:** Metri-Pack 150

**Pressure Port Material:**  
304 Stainless Steel

**Sensor Material:** 17-4PH SS

**Housing:** 20% Glass Reinforced Nylon

**Install Torque:** 27 Nm (20 ft-lbs)

## ENVIRONMENTAL RATINGS:

**Operating and Storage Temperature:**  
-40°C to 125°C

**Vibration:** 20 grms (10 hrs. each axis)

**Shock:** 100gs, 6ms

#### EMI / RFI Protection

**EN61326 (Heavy Industrial):**  
30 V/M 500 KHz to 1 GHz

**Weather Rating:** IP67

## TO ORDER

**Pressure Sensor Model No.:**

ERP-345-RM-IM-06

Part No. 4000672

**Mating Connector:**

Metri-Pack® 150

HF Part No. 4000669

## DIMENSIONS

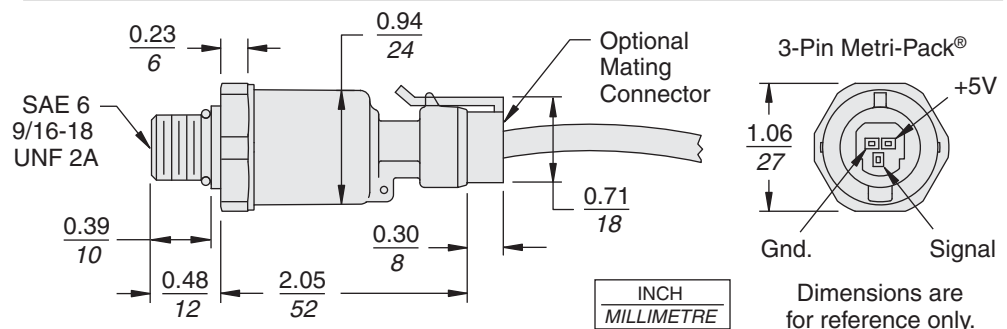

**NOTE:** See following page (3.652.2) for important Installation and Technical Reference Information.

# Pressure Sensor Installation and Reference Info.

## TECHNICAL REFERENCE INFORMATION FOR ERP MODEL PRESSURE SENSORS

### WARNING- READ BEFORE INSTALLATION

#### User Liability and Safety — OEM Responsibility

Full responsibility for the safe and effective functioning of the equipment into which HydraForce electronic controls are installed is assumed by the OEM of the equipment. HydraForce assumes no responsibility for application performance, or for the consequences of improper application or equipment malfunction.

A failure resulting in injury or damage may be caused by excessive overpressure, excessive vibration or pressure pulsation, excessive instrument temperature, corrosion of the pressure containing parts, or other misuse. Consult HydraForce Inc., Lincolnshire, IL, USA before installing if there are any questions or concerns.

#### 1. Overpressure:

Pressure spikes in excess of the rated overpressure capability of the sensor may cause irreversible electrical and/or mechanical damage to the pressure measuring and containing elements. Fluid hammer and surges can destroy any pressure sensor and must always be avoided. A pressure snubber should be installed to eliminate the damaging hammer effects. Fluid hammer occurs when a liquid flow is suddenly stopped, as with quick closing solenoid valves. Surges occur when flow is suddenly begun, as when a pump is turned on at full power or a valve is quickly opened. Liquid surges are particularly damaging to pressure sensors if the pipe is originally empty. To avoid damaging surges, fluid lines should remain full (if possible), pumps should be brought up to power slowly, and valves opened slowly. To avoid damage from both fluid hammer and surges, a surge chamber should be installed.

#### Symptoms of fluid hammer and surge's damaging effects:

- Pressure sensor exhibits an output at zero pressure (large zero offset).
- Pressure sensor output remains constant regardless of pressure
- In severe cases, there will be no output.

#### 2. Freezing:

Prohibit freezing of media in pressure port. Unit should be drained (mount in vertical position with electrical termination upward) to prevent possible overpressure damage from frozen media.

#### 3. Static Electrical Charges:

Any electrical device may be susceptible to damage when exposed to static electrical charges.

To avoid damage to the sensor observe the following:

- Ground the body of the sensor BEFORE making any electrical connections.
- When disconnecting, remove the ground LAST!

Note: The shield and drain wire in the cable (if supplied) is not connected to the sensor body, and is not a suitable ground.

#### 4. Use in Life Support Devices

HydraForce Inc. products are not authorized for use as critical components in life support devices or systems without the express written approval of the HydraForce Engineering Department. As used herein:

- Life support devices or systems are devices or systems which, (a) are intended for surgical implant into the body, or (b) support or sustain life, and whose failure to perform, when properly used in accordance with instructions for use provided in the labeling, can be reasonably expected to result in a significant injury to the user.
- A critical component is any component of a life support device or system whose failure to perform can be reasonably expected to cause the failure of the life support device or system, or to affect its safety or effectiveness.

### DESCRIPTION

The Hydraforce Model ERP pressure sensors are high performance instruments intended for use in off-highway and industrial applications where the process media is compatible with the 17-4PH stainless steel sensor material and the 304 SS process connection.

#### Mechanical Installation Guidelines:

##### Environmental

The ERP pressure sensors can be stored and used within the temperature limits of  $-40^{\circ}\text{C}$  to  $125^{\circ}\text{C}$  ( $-40^{\circ}\text{F}$  to  $257^{\circ}\text{F}$ ). Ingress protection ratings of the units are IP67 standard, but dependent on the electrical termination specified for special models.

##### Mounting

The ERP pressure sensors require no special mounting hardware and can be mounted in any orientation with negligible position error. Although the units can withstand considerable vibration without damage or significant output effects, it is always good practice to mount the sensor where there is minimum vibration. For units with NPT type pressure fittings, apply sealing tape or an equivalent sealant to the threads before installing. When installing or removing the unit apply a wrench to the hex wrench flats, located above the pressure fitting. DO NOT tighten by using a pipe wrench on the housing. A 27mm (11/16") wrench can be used on the wrench flats of the hex.

##### Electro-Magnetic Interference

The circuitry of the ERP pressure sensors is designed to minimize the effect of electromagnetic and radio frequency interference. To minimize susceptibility to noise, avoid running the termination wiring in a conduit which contains high current AC power cables. Where possible avoid running the termination wiring near inductive equipment.

##### Field Adjustments

The ERP pressure sensors are precisely calibrated and temperature compensated at the factory to ensure long and stable performance. There are no field accessible adjustments on the sensors.

##### Electrical Installation

Please refer to the performance ratings on the previous page for power supply requirements and for appropriate wiring protocol based on the particular output signal and electrical termination features of the unit being installed.