

Proportional Valve Controller—DIN Coil Mount—

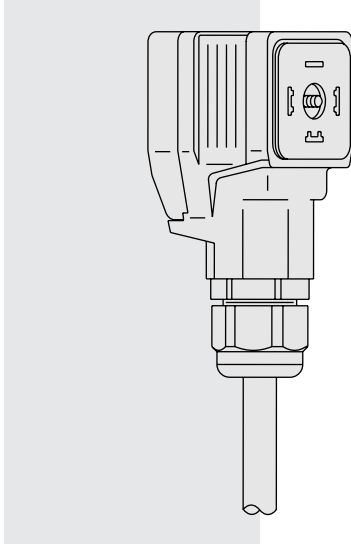

DESCRIPTION **4–20 mA Input**

A convenient, plug-mounted control amplifier for controlling HydraForce proportional valves that have solenoids with DIN 43650A/ISO 4400 electrical connectors.

OPERATION

This control module uses closed-loop current control with superimposed dither to supply a proportional valve solenoid with a proportional control signal. This controller will accept a 4–20 mA input signal from a programmable logic controller (PLC) or other control systems.

FEATURES

- Mounts directly to solenoid coils with DIN 43650A connectors.
- IP65 weather resistant when used with base gasket (supplied).
- Adjustments accessible with a removable cover.
- One unit covers supply voltages from 9 to 32 VDC.
- No internal fuses; circuit limits current electronically.
- Short circuit proof and reverse polarity protected.
- Connector can be disconnected from coil when powered.
- Maximum current adjustment does not affect minimum current setting.
- Independent ramp adjustments.
- Dither frequency and amplitude are adjustable for maximum valve performance.

GENERAL SPECIFICATIONS

- Plug Housing:** Polyamide
Plug Lid: Polycarbonate
Weight: 30 g (1.06 oz.) without cable
Connections: Mounted cable with unterminated wires provided; Length: approximately 2 meters (79")

RATINGS

- Supply Voltage:** 9–32 VDC
 Coil rating must be matched with supply voltage: $R_{COIL} \leq (V_{SUPPLY} - 1.5 V) / I_{MAX}$.
- Control Input Signal Options:** 4–20 mA current signal
Input Resistance: 50 Ohms
Output Current: 1200 mA
Minimum Current Range: 0–150 mA, adjustable
Maximum Current Range: 400–1200 mA, adjustable
Ramp Up and/or Down: 0.01–5.0 seconds, independently adjustable
Dither Frequency: 70–350 Hz, adjustable
Dither Amplitude: 0–10% of maximum current, adjustable
Operating Conditions: –40° to 85°C; 0 to 85% relative humidity
Environmental Protection: IP65 with cover and base gasket installed

SCHEMATIC

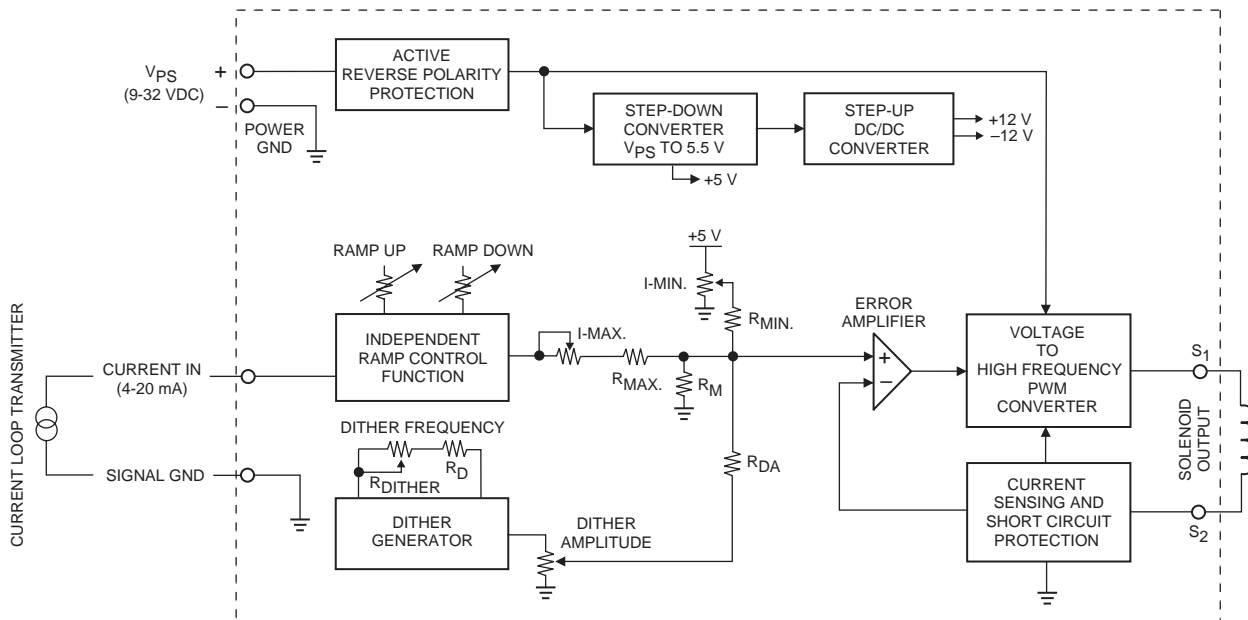

4-20 mA Input

DIMENSIONS

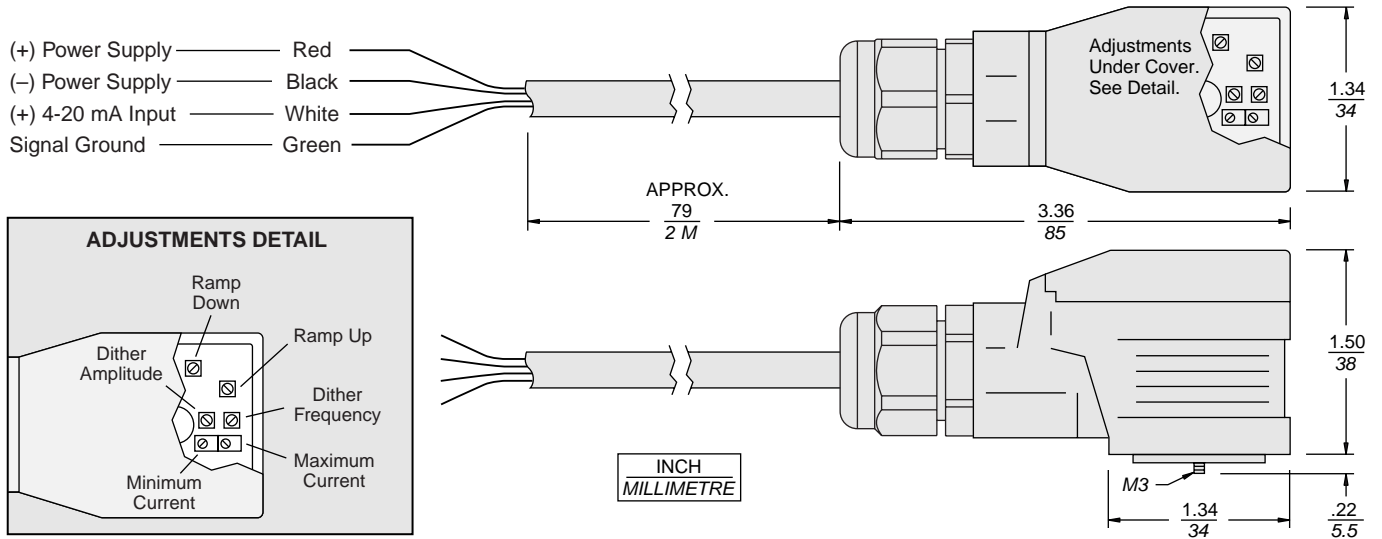

CONNECTIONS

For Complete Set-Up Instructions, see page 3.439.1

Basic Setup:

Turn ramp screws fully counterclockwise to eliminate ramping.
 Use I-Min. screw to set minimum speed with minimum control input.
 Use I-Max. screw to set maximum speed with 100% of control input.

4 to 20 mA Control

Supplied by User	Wire Color
(+) Power	Red
(-) Power	Black
(+) 4-20mA	White
(-) 4-20mA	Green

TO ORDER

Part Number	Output	I-Min. Setting	I-Max. Setting	Cable Length
4000169	1200 mA Max.	0 to 150 mA	400 to 1200 mA	2 meters