

EFDR1 Valve Driver, Fan Control, Plug-In Style

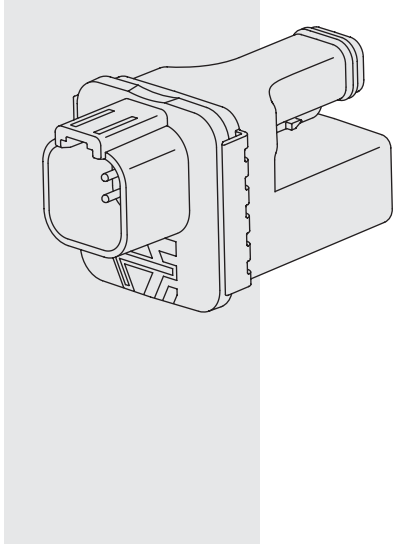

DESCRIPTION

A convenient, plug-mounted microprocessor-based controller intended for use on a TSxx-21 or TSxx-27 hydraulic proportional valve for fan control applications. The input signal to the controller can be a temperature sensor, PWM, voltage, or current.

OPERATION

This fan drive controller can be configured for a single or dual output control based on a single input signal. A single output would be used to control a single solenoid proportional valve coil for flow or pressure control. As the temperature increases the current decreases. All input and output endpoints and breakpoints can be adjusted via a PC interface and configuration software.

There are two modes of automatic operation: On/Off and Proportional. There is also a Reversing feature which allows the operator to blow any debris out of the radiator by reversing the direction of fan rotation.

RATINGS

Operating Temperature: -40°C to +85°C (-40°F to +185°F)

Molded Enclosure Dimensions: 35.1mm(W) x 72.9mm(H) x 42.67mm (D);
1.38 in.(W) x 2.87 in. (H) x 1.68 in. (D)

Mating Connectors: Deutsch DT06-6S and DT04-2P

Solenoid Connector: Integral HF DR 2-Pin

Power Requirements: 9 to 32 VDC

Control Inputs: Voltage: 0 to 5 or 0 to 10 VDC; Current: 4 to 20 mA;
Negative or Positive Temperature Coefficient (NTC or PTC) sensor;
Resistive: 60 to 6500 ohms; PWM: 5 to 95%, 1.5V to 3.5V, 100 Hz to 10 KHz

Control Outputs: 50 to 2000 mA

Dither: 50 to 400 Hz; 0 to 50% of I-Max

Ramp Time: 0.0 to 10.0 seconds; I-Min to I-Max

Sealing: IP67 rated

DIAGNOSTIC FEATURES

- Any input below 9 VDC or above 32 VDC for a duration of 100ms will cause the controller to default to safe mode of "valve off."
- Any absence of an input signal caused by an open or short will cause the controller to default to safe mode of "valve off max. pressure."
- Any no-current (open) output condition or over-current (short) will cause the controller to default to safe mode of "valve off max. pressure."
- When a fault is corrected the controller will return to a proper operating mode.

DIMENSIONS

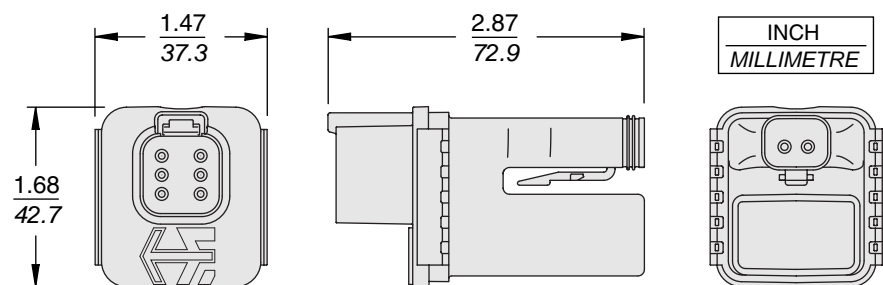

MOUNTING CONSIDERATIONS

When installing the coil on a horizontal plane, the controller should be orientated as closely as possible to vertical alignment with the coil, as shown in Fig 1. When mounted in this position, the controller will withstand the vibration test profile described on HydraForce catalog page 3.400.3 (Test No. 4).

Avoid mounting the controller on a horizontal axis with the coil, as shown in Fig. 2.

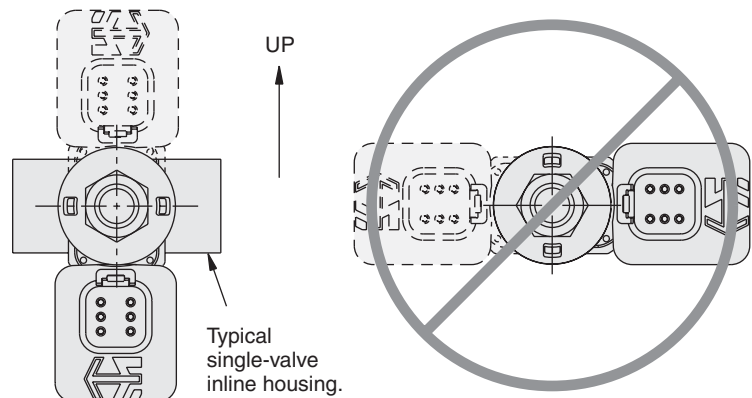

FIG. 1: CORRECT INSTALLATION

FIG. 2: INCORRECT INSTALLATION

EFDR1 Valve Driver, Fan Control, Plug-In Style

CONNECTIONS & WIRING

Description	Interface	I/O	Pin	Connector
Battery	Power+	A/0	4	DT04-6P
	Power-	Pgnd	5	
Control Input	Temperature Signal	A/1	3	
	Temperature Return	Agnd	2	
Solenoid "B" Reverse	Solenoid B+	AO2	6	
	Solenoid B-	Pgnd	1	
Solenoid "A" Control	Solenoid A+	AO1	1	DT06-2S
	Solenoid A-	Pgnd	2	

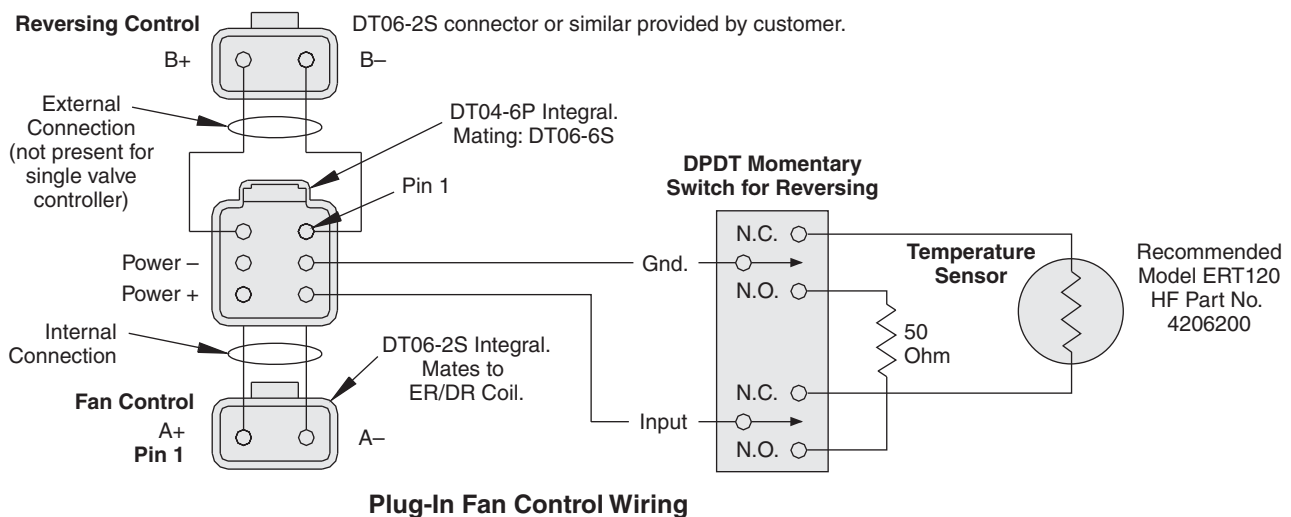

CONTROL MODES (based on default values)

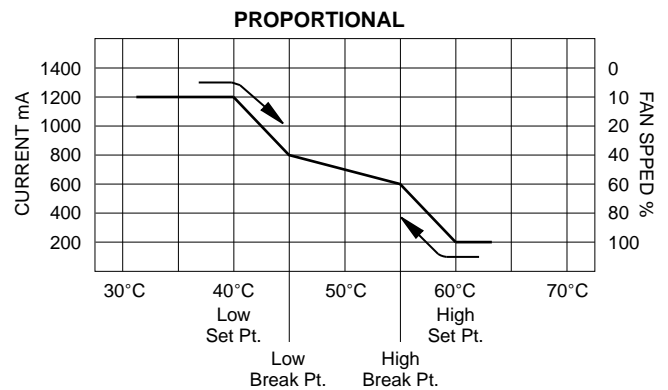
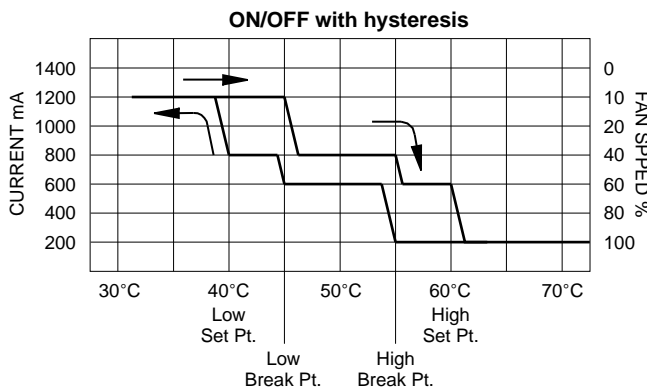

TO ORDER

- EFDR1 Fan Control Valve Driver — Part No. **4204500**
- Configuration Cable for ExDR1 — Part No. **4001605**
- Configuration Software for ExDR1 — Part No. **4001618**
- Recommended Temperature Sensor, Model ERT120 — Part No. **4206200**