

EFDR2 Valve Driver, Fan Control, Multi-Input,



FEATURES

- Complete Closed-Loop System Controller.
- Settings by pre-written PC program.
- CE Compliant for global application.
- PC Data Logging feature for trend analysis.
- Visible diagnostics with LED system 'error' blink code warning.
- Alarm output for integrated system interface/shutdown options.
- Fully protected against shorts, opens, and reverse connections.
- Fan 'Start-up Delay' feature to prevent excessive cooling.
- Flame-proof resin encapsulation.
- Reversing can be initiated manually or automatically.
- Various password levels ensure that characteristics cannot be changed without proper authority.
- Suitable for on- or off-road use.
- Industry-standard, sealed, Weather-pack or two-part polarized connectors.
- Fan Noise Test feature for demonstrating the proper noise level of a forward driven fan.

DESCRIPTION

The EFDR2 multi-input fan drive controller provides precise, repeatable control of one proportional valve coil and one on/off solenoid valve coil. The controller accepts up to three thermistor inputs for fan control along with a single switch input for manual activation of the fan reversal function. Controller input signals can be from a resistive temperature sensor, or analog switch inputs. The EFDR2 setup parameters are configured using a PC, or the Application Configuration Programmer (ACP) serial interface, which allows for infrared programming and field adjustment of the controller. This multi-input fan drive controller is suitable for a wide range of heavy duty industrial, marine, and mobile off-highway equipment applications requiring proportional fan control.

RATINGS

POWER REQUIREMENTS:

Power Required: 10 to 32 VDC

INPUT SUPPLY CURRENT:

One: 200 mA Quiescent

All input and output characteristics are configurable with the Application Configuration Programmer (ACP) software.

INPUTS — Three Command Inputs:

Three discrete thermistor inputs: OHMS only (Max. Temp. = 50; Min. Temp. = 2M)

Note: a thermistor input reaching 'Overtemp' will result in ramping to full fan speed.

One Reversing Input: Digital: Active High

Dither Frequency: ~30 to 250Hz (menu selectable)

OUTPUTS — Two Control Outputs:

Operating Current: Max. load for proportional valve

One, On/Off Sourcing Driver: (3A)

One, Proportional: (3.3A)

Proportional and Directional Coils: 8-14VDC: Use 12V coil;
20-36VDC: Use 24V Coil

ENVIRONMENTAL RATINGS:

Operating Temp. Range: -30°C to +75°C; Storage Temp. Range: -40°C to +85°C

Humidity Tolerance: 95-100% Non-Condensing

Moisture Leakage (sealant pressure tolerance): ±0.35 bar (5 psi) against water and water vapor; immersion resistant in 3 ft. (1 meter) of water; meets IP68 standards.

MATERIALS:

Housing: Polycarbonate with flame resistant, two-part Epoxy Resin

Thermistor Input w/USB Interface

DIMENSIONS

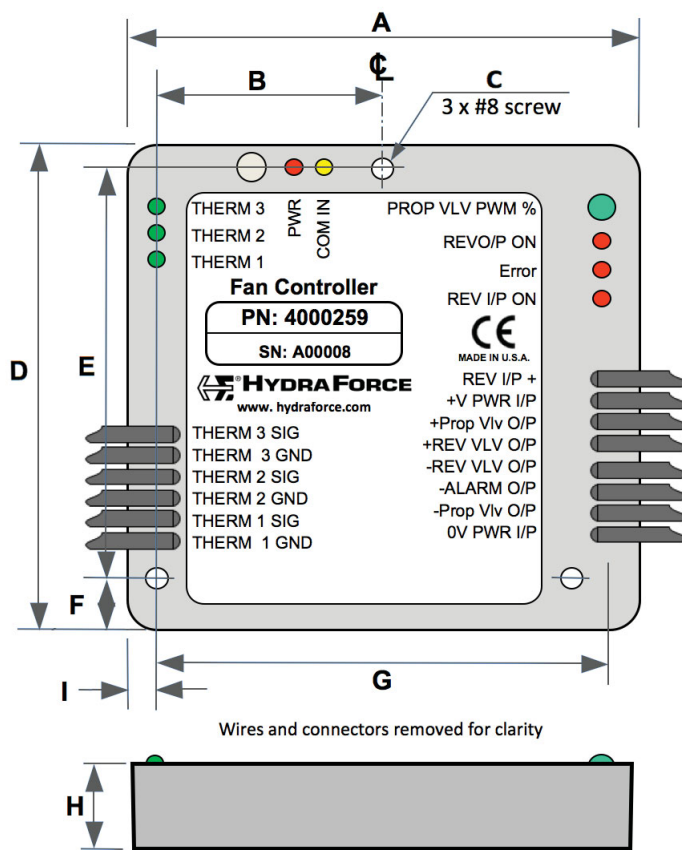

Label	Dimension
A	3.77 in./96.0 mm
B	1.89 in./48.0 mm
C	0.186 in./5.0 mm Dia.
D	3.82 in./97.0 mm
E	3.10 in./78.8 mm
F	0.46 in./12.0 mm
G	3.25 in./82.6 mm
H	0.64 in./16.5 mm
I	0.26 in./6.5 mm

Dimensions are for reference only.

Wires and connectors removed for clarity

PINOUT

Connector 1

Pin	Function
1	Thermistor 3 Sig
2	Thermistor 3 Gnd
3	Thermistor 2 Sig
4	Thermistor 2 Gnd
5	Thermistor 1 Sig
6	Thermistor 1 Gnd

Connector 2

Pin	Function
1	Reverse I/P+
2	+V Power I/P
3	+Prop Valve O/P
4	+Reverse Valve O/P
5	-Reverse Valve O/P
6	Alarm O/P
7	-Prop Valve O/P
8	0V Power I/P

Notes:
 The engine Coolant Sensor must be connected to Thermistor 1 input.
 The Charge Air Sensor must be connected to Thermistor 2 input.

TO ORDER

- EFDR2 Fan Control Valve Driver** — Part No. **4000259**
- Connector Kit for EFDR2** — Part No. **4000266**
- Configuration Kit for EFDR2**
 Includes Application Configuration Programmer (ACP), and USB Cable — Part No. **4000260**
 Software GUI — Part No. **4100041**
- Recommended Temperature Sensor: Model ERT150** — Part No. **4204440**
- Mating Connector for Recommended Temperature Sensor** — Part No. **4001951**