

ETDR1 Dual/Single Transmission Valve Driver, Plug-In

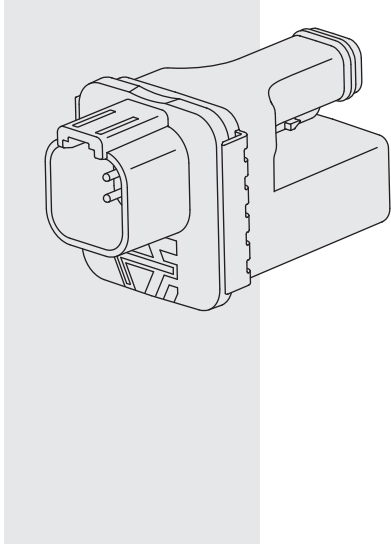

DESCRIPTION

A convenient, plug-mounted microprocessor-based controller for use on a hydraulic proportional valve coil. The input signal to the controller can be configured as voltage, current, resistive, or PWM.

OPERATION

The ETDR1 can be configured to provide a smooth clutch operation on a transmission. The controller will output the required current to fill the clutch, hold the output and then ramp the current output to full engagement of the shift. This will happen under a configurable preset timed function when the neutral to in gear is required. See Clutch Engagement Profile graph below.

Once the transmission is engaged the controller will also operate in the inch/troll which will allow slow precise control based on the amplitude of the input signal.

The input signal can originate from a joystick type device with PWM, Voltage, or Resistance output. The two outputs of the ETDR1 provide for both forward and reverse control.

RATINGS

Operating Temperature: -40°C to $+85^{\circ}\text{C}$ (-40°C to $+185^{\circ}\text{F}$)

Molded Enclosure Dimensions: 35.1mm(W) x 72.9mm(H) x 42.67mm (D);
1.38 in.(W) x 2.87 in. (H) x 1.68 in. (D)

Mating Connectors: Deutsch DT06-6S and DT04-2P

Solenoid Connector: Integral HF DR 2-Pin

Power Requirements: 9 to 32 VDC

Control Inputs: Voltage: 0 to 5 or 0 to 10 VDC; Current: 0 to 20 or 4 to 20 mA
Resistive: 0 to 5K ohms; PWM: 5 to 95%, 1.5V to 3.5V, 100 Hz to 10 KHz

Control Outputs: 50 to 2000 mA

Dither: 70 to 350 Hz; 0 to 10% of I-Max

Ramp Time: 0.0 to 5.0 seconds; I-Min to I-Max

Sealing: IP67 rated

Materials: Polyester, 15% glass with silicone seals

DIAGNOSTIC FEATURES

- Any input below 9 VDC or above 32 VDC for a duration of 100ms will cause the controller to default to safe mode of "valve off."
- Any absence of an input signal caused by an open or short will cause the controller to default to safe mode of "valve off."
- Any no-current (open) output condition or over-current (short) will cause the controller to default to safe mode of "valve off."
- When a fault is corrected the controller will return to a proper operating mode.

RAMP PROFILE EXAMPLES (Output A shown with default settings)

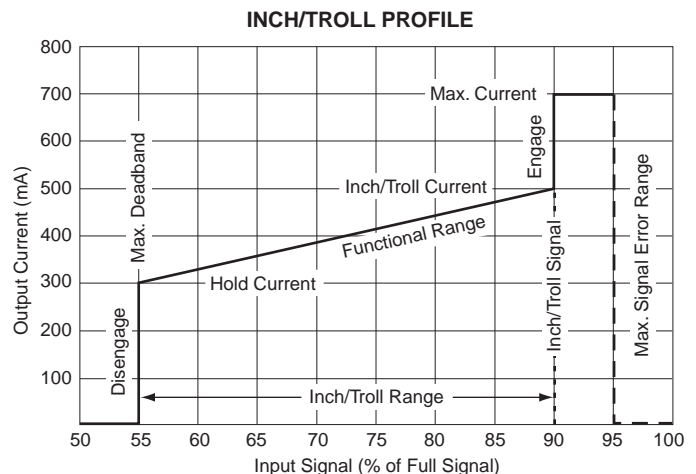
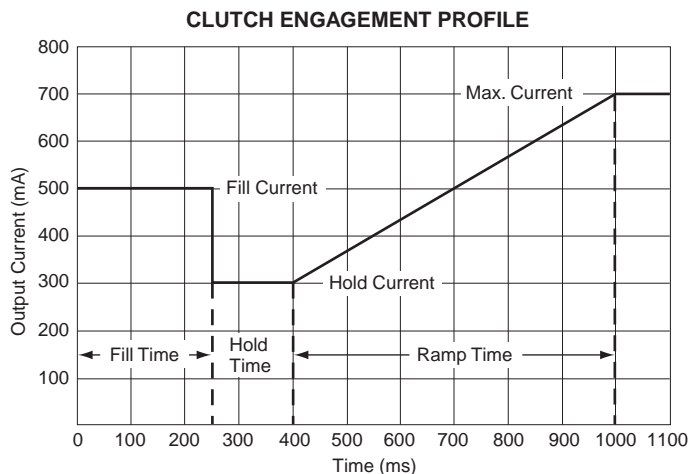

ETDR1 Dual/Single Transmission Valve Driver, Plug-In

CONNECTIONS & WIRING

Description	Interface	I/O	Pin	Connector
Battery	Power+	A/0	4	DT04-6P
	Power-	Pgnd	5	
Voltage Control Signal	Voltage in	A/1	3	
	Gnd	Agnd	2	
Current Control Signal	0 to 20 mA in	A/1	3	
	4 to 20 mA in	A/1	3	
	Gnd	Agnd	2	
Resistive Control Signal	Radj in	A/1	3	
	Gnd	Agnd	2	
PWM Control Signal	PWM in	A/1	3	
	Gnd	Agnd	2	
External Solenoid Reverse	Sol B+	AO2	6	DT06-2S
	Sol B-	AO3	1	
Integral Solenoid Forward	Sol A+	AO1	1	DT06-2S
	Sol A-	Pgnd	2	

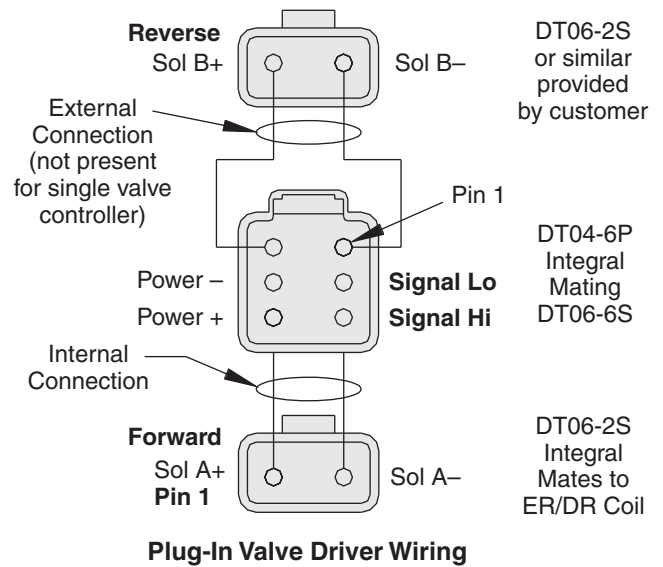

DIMENSIONS & MOUNTING

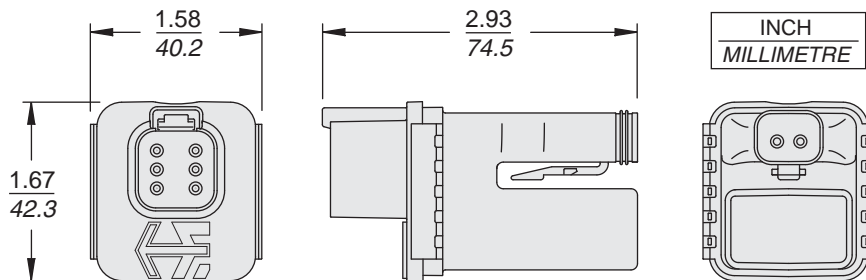

MOUNTING CONSIDERATIONS

When installing the coil on a horizontal plane, the controller should be orientated as closely as possible to verticle alignment with the coil, as shown in Fig 1. When mounted in this position, the controller will withstand the vibration test profile described on HydraForce catalog page 3.400.3 (Test No. 4).

Avoid mounting the controller on a horizontal axis with the coil, as shown in Fig. 2.

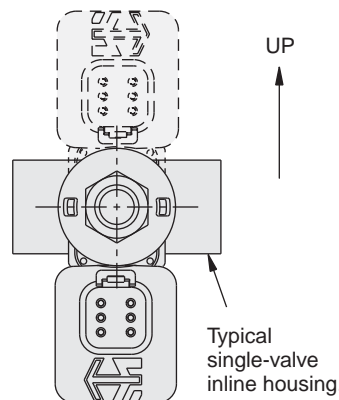

FIG. 1: CORRECT INSTALLATION

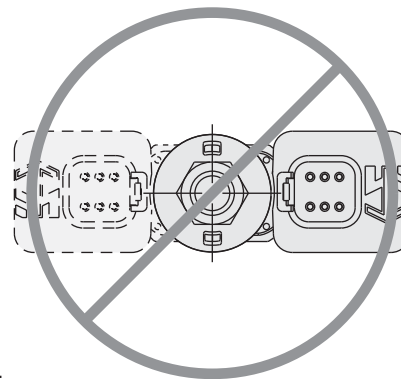

FIG. 2: INCORRECT INSTALLATION

TO ORDER

Dual/Single Transmission Control Valve Driver Model ETDR1 — Part No. 4204520

Configuration Cable for ExDR1 — Part No. 4001605

Configuration Software for ExDR1 — Part No. 4001618