

## EVDR4 Five-Valve Driver, Universal Input

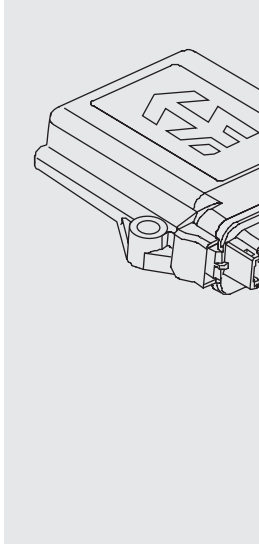

### FEATURES

- Microprocessor based control (standard software or OEM software on request).
- Standard hardware and software adapts to many applications including interface to a joystick PWM command or proportional signals.
- Independent outputs for four proportional valves (0...2A) and 1on/off valve (< 2 A).
- Interfaces to up to 2 PWM signal inputs (interface to a 2 axis joystick).
- Up to four voltage or current analog inputs: 0-5V, 0-10V, 4-20 mA or 0-20 mA.
- Digital inputs for interface to switches, etc., (up to 6).
- Robust 8...36VDC power supply interface with reverse polarity protection.
- One, +5V reference voltage to power input devices.
- Thermal overload and overvoltage protection provided.
- Rugged IP67-rated packaging with IP69K-rated plug-in connections.
- Operational from -40 to 85°C (-40 to 185°F).
- RS232 interface to PC or laptop for user configuration and diagnostics.

### DESCRIPTION

The EVDR4 valve driver provides precise, repeatable control of four proportional solenoid valve coils and one on/off solenoid valve coil. PWM input signals can be from a joystick, a PLC or Engine Control Module. Analog inputs and multiple switched inputs are optional to suit a range of applications. An onboard RS-232 port is used for user-configuration and diagnostics via PC.

This versatile, multi-function controller is suitable for a wide range of heavy duty industrial, marine, and mobile off-highway equipment applications, such as transmission controls, vehicle traction controls, and drive-by-wire control systems.

### RATINGS

#### POWER REQUIREMENTS:

Power Required: 9 to 32 VDC  
Operating Current: 7 amp maximum load  
Non-Destructive Voltage: -32 to +36 VDC

#### SENSOR POWER SUPPLY:

One, 5V Sensor Supply: 50 mA DC

#### PROCESSING and MEMORY:

Motorola Microprocessor: MC56F8346  
Flash ROM: 128 KByte  
SRAM: 4 KByte  
EEPROM: 8 KBytes

**All input and output characteristics are configurable with ACP (Application Configuration Programmer).**

#### INPUTS:

PWM/Digital: 2 inputs  
5 to 36 VDC; 0 to 100% DC; 50 Hz to 10 KHz; or Digital Active High/Low Input  
Analog/Digital: 4 inputs  
0 to 20 mA; 4 to 20 mA, 0 to 5V or 0 to 10V; or Digital Active High or Low

#### OUTPUTS:

On/Off High Side Driver (2A): 1  
PWM Driver, High Side (2A): 4;  
PWM Drivers can be configured for On/Off or Proportional  
Communications: RS-232

#### ENVIRONMENTAL RATINGS:

Operating Temperature Range: -40°C to +85°C  
Storage Temperature Range: -50°C to 125°C  
Humidity Tolerance: 115% of nominal system voltage at 90% relative humidity over operating temperature range  
Salt Spray Tolerance: 115% of nominal system voltage with 5% salt spray for 48 hours at 35°C  
Chemical Splash Immunity: Diesel Fuel, engine/machine oil, SAE J1455 chemical agents  
Vibration (Shock-isolated components): 7.4 Grms random vibration from 24 Hz to 2 KHz in three orthogonal planes  
Moisture Leakage (sealant pressure tolerance): ±0.35 bar (5 psi) against water and water vapor; immersion resistant in 3 ft. (1 meter) of water; meets IP67 standards.  
Radiated Immunity: 10 V/M; 80 MHz to 1.0 GHz  
Electrostatic Environment: Zero damage during exposure to electrostatic painting process (IEC 61000-4-2)

#### Materials:

Housing: Thermoplastic with silicone elastomer seals.  
Contacts: Tin-plated copper alloy.

# EVDR4 Five-Valve Driver, Universal Input

## DIMENSIONS

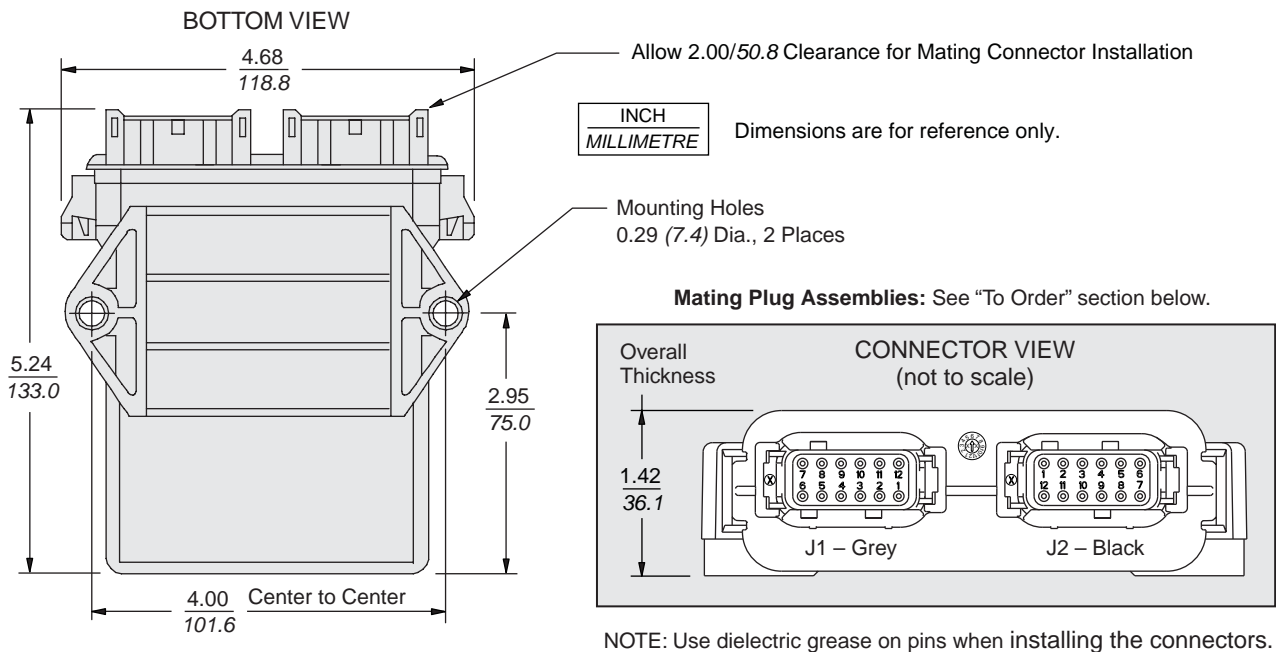

## PINOUT

### Connector J1 – Grey

Pin	Function
1	Power +
2	Proportional Solenoid 1+
3	Proportional Solenoid 2+
4	Proportional Solenoid 3+
5	Proportional Solenoid 4+
6	Digital Solenoid +
7	Digital Solenoid –
8	Proportional Solenoid 4–
9	Proportional Solenoid 3–
10	Proportional Solenoid 2–
11	Proportional Solenoid 1–
12	Power –

**Pinout Notes:** To ground a PWM input use an analog GND connection pin. Active high digital inputs can be connected to the +5V reference. Active low inputs can be grounded to the analog GND connection pin. Joystick commands X and Y axes affect solenoids depending on how the joystick is wired to the controller. X and Y mentioned here may not correspond to the wiring chosen in a particular application.

Use RS232 cable with the following pinout to make this connection:

J2 Black, Pin 7 -> TXD -> female DB-9 Pin 2  
 J2 Black, Pin 8 -> RXD -> female DB-9 Pin 3  
 J2 Black, Pin 9 -> GND -> female DB-9 Pin 5

### Connector J2 – Black

Pin	Function
1	CAN-H
2	CAN-L
3	Analog In 1 / Digital In 1 (Controls the digital output when PWM command type is selected.)
4	Analog In 2 / Digital In 2 (ENABLE control when PWM command type is selected.)
5	Analog In 3 / Digital In 3 (Not used in standard software.)
6	Analog In 4 / Digital In 4 (Not used in standard software.)
7	RS232 Transmit (See Notes.)
8	RS232 Receive (See Notes.)
9	Analog Ground (and RS232 Ground)
10	+5V Reference
11	PWM In 1 / Digital In 5 (Controls the digital output when analog command type is selected; See notes.)
12	PWM In 2 / Digital In 6 (ENABLE control when analog command type is selected; See Notes.)

## TO ORDER

**Controller:** Model EVDR4; Part No. 4000245

**Connector Kits:** J1, DTM06-12A Kit, Grey: 4001976  
 J2, DTM06-12B Kit, Black: 4001977

**Configuration Software:** 4100005

**Configuration Cable:** 4000698