

EVDR7 Multi-I/O Controller and/or Slave Module

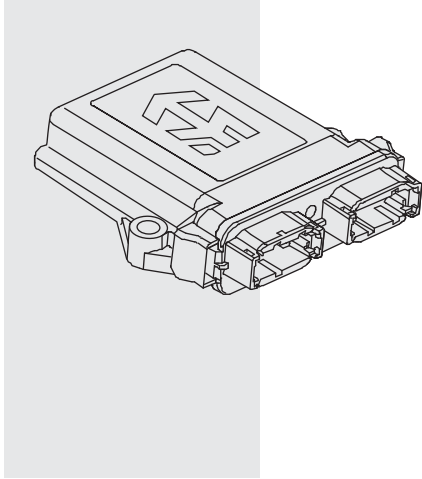

FEATURES

- Microprocessor based control (standard software or OEM software on request).
- Standard hardware and software adapts to many applications.
- Independent outputs for one proportional valve (0 to 2A) and one on/off valve (2A).
- Up to four universal analog or digital inputs: voltage, current, resistive, PWM, frequency, or digital.
- Digital input (one) for interface to switch, etc.
- Priority control sensor, selectable.
- Robust 8-60 VDC power supply interface with reverse polarity protection.
- Four, +5V reference voltage-to-power input devices (100mA w/output to common ground).
- Thermal overload and overvoltage protection provided.
- Rugged IP67-rated packaging with IP69K-rated plug-in connections.
- Operational from -40 to 85°C (-40 to 185°F).
- CAN for networking capability, user configuration and diagnostics.

DESCRIPTION

The EVDR7 multi-I/O controller provides precise, repeatable control of one proportional solenoid valve coil and one on/off solenoid valve coil. Controller input signals can be resistive temperature sensor, frequency, PWM, digital, voltage, or current. Analog inputs and multiple switched inputs are optional to suit a range of machine applications. The CAN J1939 communications port, along with the USB-to-CAN adapter, allows the EVDR7 setup parameters to be configured using a PC. Also, the CAN port can be set up to provide communications with other devices on the network. This multi-input controller is suitable for a wide range of heavy duty industrial, marine, and mobile off-highway equipment applications.

RATINGS

POWER REQUIREMENTS:

Power Required: 8 to 60 VDC; Operating Current: 6 amp maximum load
Non-Destructive Voltage: -32 to +80 VDC

SENSOR POWER SUPPLY:

Four, 5V Sensor Supplies: 100 mA DC each

PROCESSING and MEMORY:

Motorola Microprocessor: MC56F8346; Flash ROM: 128 KByte
SRAM: 4 KByte; EEPROM: 8 KBytes

All input and output characteristics are configurable with ACP (Application Configuration Programmer).

INPUTS: Four universal inputs can be chosen in the following ranges:

- Voltage, current, or resistive analog inputs:
0-1V, 0-2.5V, 0-5V, 0-10V, 0-20 mA, 4-20 mA, or 30K to 300K ohms.
- PWM, frequency, or digital inputs:
PWM: Two @ 0-100% D.C., 10 Hz to 1 KHz, or 100 Hz to 10 KHz
Frequency: Two ranges, 10 Hz to 1 KHz, or 100 Hz to 10 KHz
Digital: Active High

OUTPUTS: Two control outputs:

One, On/Off Sinking or Sourcing Driver (2A)
One, High side grounded, 0-2000mA configurable as:
Discrete: On/Off; Current: PWM Closed Loop; Duty Cycle: PWM Open Loop

ENVIRONMENTAL RATINGS:

Operating Temp. Range: -40°C to +85°C; Storage Temp. Range: -50°C to 125°C
Humidity Tolerance: 115% of nominal system voltage at 90% relative humidity over operating temperature range.
Salt Spray Tolerance: 115% of nominal system voltage with 5% salt spray for 48 hours at 35°C.
Chemical Splash Immunity: Diesel fuel, engine/machine oil, SAE J1455 chemical agents.
Vibration (Shock-isolated components): 7.4 Grms random vibration from 24 Hz to 2 KHz in three orthogonal planes.
Moisture Leakage (sealant pressure tolerance): ±0.35 bar (5 psi) against water and water vapor; immersion resistant in 3 ft. (1 meter) of water; meets IP67 standards.

Materials:

Housing: Thermoplastic with silicone elastomer seals.
Contacts: Tin-plated copper alloy.

Universal Input, w/J1939,

EVDR7

DIMENSIONS

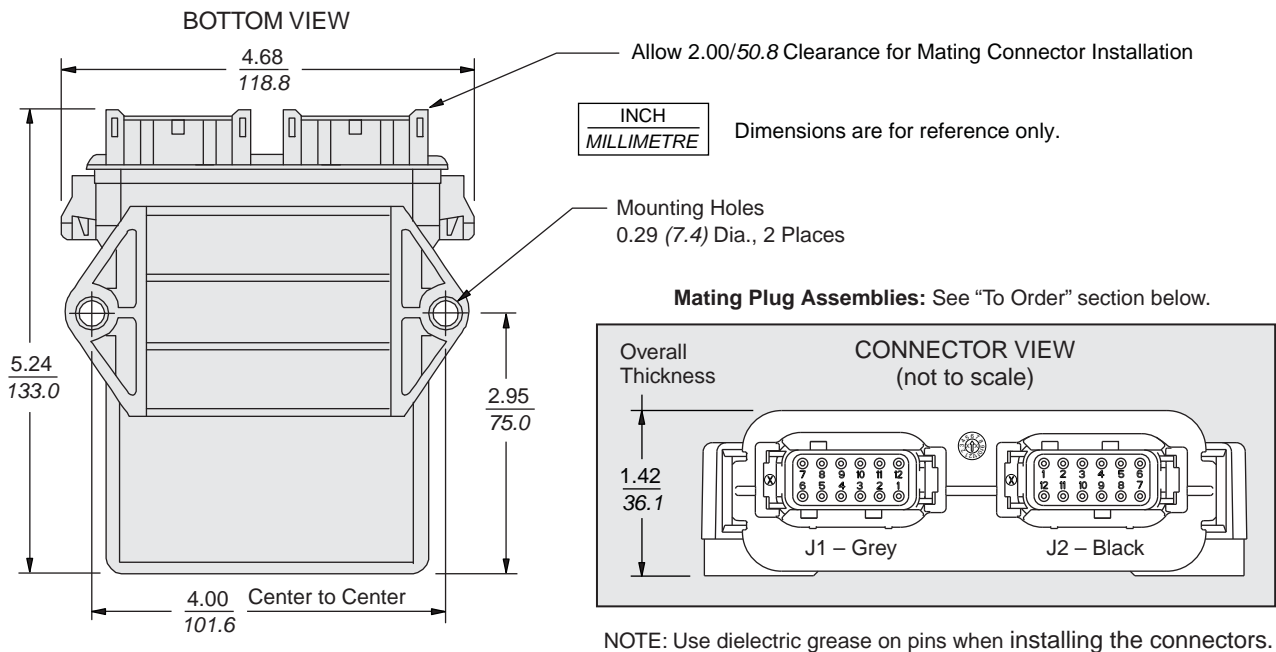

PINOUT

Connector J1 – Grey

Pin	Function
1	CAN_SH
2	Not Used
3	Output 2 Return
4	Output 1 Return
5	BATT –
6	BATT –
7	BATT +
8	BATT +
9	Output 1 Driver
10	Output 2 Driver
11	CAN Hi
12	CAN Lo

Connector J2 – Black

Pin	Function
1	5 Vref 1
2	Input 1
3	Analog Ground
4	Analog Ground
5	Input 2
6	5 Vref 2
7	5 Vref 3
8	Input 3
9	Analog Ground
10	Analog Ground
11	Input 4
12	5 Vref 4

Pinout Notes:

To ground a PWM input use an analog GND connection pin.
Active high digital inputs can be connected to the +5V reference.
Active low inputs can be grounded to the analog GND connection pin.

TO ORDER

Controller Model EVDR7; Part No. 4000258

Connector Kits: J1, DTM06-12A Kit, Grey: Part No. 4001976
J2, DTM06-12B Kit, Black: Part No. 4001977

Configuration Kit

Includes Converter, USB Cable and Software: Part No. 4000250

CAN Flashing Cable: Part No. 4000682