

EVDR18 *Eighteen Digital Input Module with J1939*

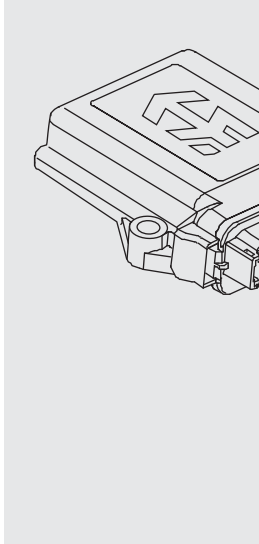

FEATURES

- Microprocessor based control (standard software or OEM software on request).
- Standard hardware and software adapts to many applications.
- Robust 8 to 32VDC power supply interface with reverse polarity protection.
- Thermal overload and overvoltage protection provided.
- Rugged IP67-rated packaging with IP69K-rated plug-in connections.
- Operational from -40 to 85°C (-40 to 185°F).
- CAN for networking capability, user configuration and diagnostics.

DESCRIPTION

The EVDR18 Input Module measures up to 18 inputs and sends the data over a CAN network. The 10 inputs can be configured for Digital (High or Low). The remaining 8 inputs can be configured for Digital (High or Low), PWM, Freq/RPM, or Counter. CAN bus communications offer control system networking capability and is used for configuration.

This versatile, multi-function module is suitable for a wide range of heavy duty industrial, marine, and mobile off-highway equipment applications, such as transmission controls, vehicle traction controls, and drive-by-wire control systems.

RATINGS

POWER REQUIREMENTS:

Power Required: 8 to 32 VDC
 Operating Current: 0.10 amps maximum, typically less than 2W
 Non-Destructive Voltage: -32 to +75 VDC

PROCESSING and MEMORY:

Motorola Microprocessor: DSP56F8346
 Flash ROM: 128 KByte
 SRAM: 4 KByte
 EEPROM: 8 KBytes

All input and output characteristics are configurable with ACP (Application Configuration Programmer).

COMMUNICATION I/O:

CAN J1939 — Standard
 CANopen — Consult Factory

Inputs:

Type	Range	Accuracy
PWM	0 to 100%, 1Hz to 10KHz, 32Vp-p	±1.25%
RPM	50Hz to 10KHz, 50mV to 3V RMS	±1.0%
Counter	0 to 32 VDC, 10KHz	—
Digital	0 to 32 VDC, 2.5V Threshold	—

ENVIRONMENTAL RATINGS:

Operating Temperature Range: -40°C to +85°C
 Storage Temperature Range: -50°C to 125°C
 Humidity Tolerance: 115% of nominal system voltage at 90% relative humidity over operating temperature range
 Salt Spray Tolerance: 115% of nominal system voltage with 5% salt spray for 48 hours at 35°C
 Vibration (Shock-isolated components): 7.4 Grms random vibration from 24 Hz to 2 KHz in three orthogonal planes
 Moisture Leakage (sealant pressure tolerance): ±0.35 bar (5 psi) against water and water vapor; immersion resistant in 3 ft. (1 meter) of water; meets IP67 standards.
 Radiated Immunity: 10 V/M; 80 MHz to 1.0 GHz
 Electrostatic Environment: Zero damage during exposure to electrostatic painting process (IEC 61000-4-2)

Materials:

Housing: Thermoplastic with silicone elastomer seals.
 Contacts: Tin-plated copper alloy.

EVDR18 Eighteen Digital Input Module with J1939

DIMENSIONS

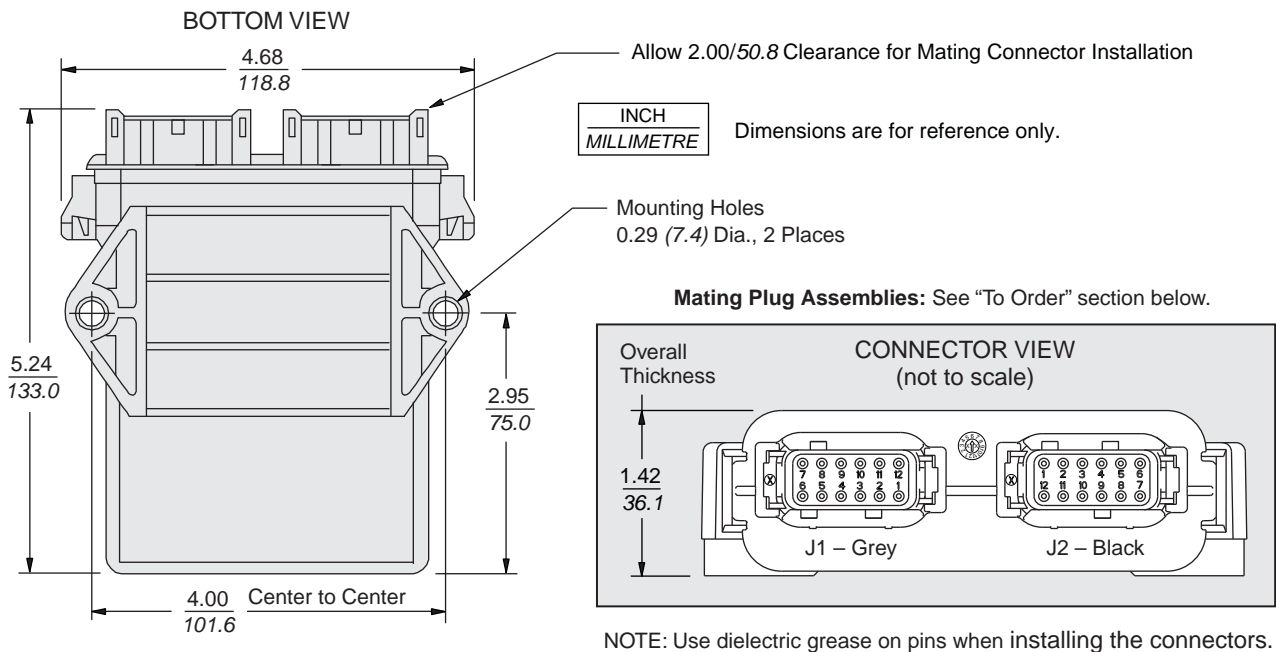

PINOUT

Connector J1 – Grey

Pin	Function
1	CAN HI
2	CAN LO
3	CAN_SH
4	GND
5	Power –
6	Power +
7	Input 6
8	Input 5
9	Input 4
10	Input 3
11	Input 2
12	Input 1

Connector J2 – Black

Pin	Function
1	Input 7
2	Input 8
3	Input 9
4	Input 10
5	Input 11
6	Input 12
7	Input 18
8	Input 17
9	Input 16
10	Input 15
11	Input 14
12	Input 13

TO ORDER

Controller Model EVDR18; Part No. 4000262

Connector Kits: J1, DTM06-12A Kit, Grey: 4001976
J2, DTM06-12B Kit, Black: 4001977

Configuration Kit

Includes Converter, Cable and Software: 4000250

CAN Flashing Cable: Part No. 4000683