

FC10-21 Flow Control

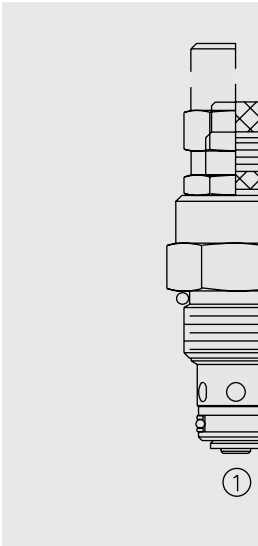

DESCRIPTION

A screw-in, cartridge-style, variable orifice, hydraulic flow control valve with reverse flow check.

OPERATION

The FC10-21 increases its orifice value from fully closed to fully open with clockwise adjustment rotation.

FEATURES

- Adjustments cannot be backed out of the valve.
- Desired settings may be locked down.
- Hardened parts for long life.
- Industry common cavity.
- Aluminum knob option.
- Positive shut-off.
- Linear adjustment.

RATINGS

Operating Pressure: 240 bar (3500 psi)

Flow: 57 lpm (15 gpm) nominal at 5.5 bar (80 psi) at full open 2.0 turns

Internal Leakage: 0.50 cc/minute (10 drops/minute) max. at shut-off

Adjustment Torque Required: 0.34 Nm (3 inch-pounds) at 7 bar (100 psi);
4.50 Nm (40 inch-pounds) at 207 bar (3000 psi)

Free Reverse Flow Check Bias Spring: See ordering information

Temperature: -40 to 120°C

Filtration: See page 9.010.1

Fluids: Mineral-based or synthetics with lubricating properties at viscosities of
7.4 to 420 cSt (50 to 2000 sus); See Temperature and Oil Viscosity, page 9.060.1

Installation: No restrictions; See page 9.020.1

Cavity: VC10-2; See page 9.110.1 (Cavity Variation "A")

Cavity Tool: CT10-2XX; See page 8.600.1

Seal Kit: SK10-2X-M; See page 8.650.1

SYMBOLS

USASI:

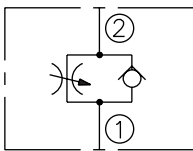

ISO:

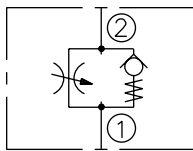

PERFORMANCE (Cartridge Only)

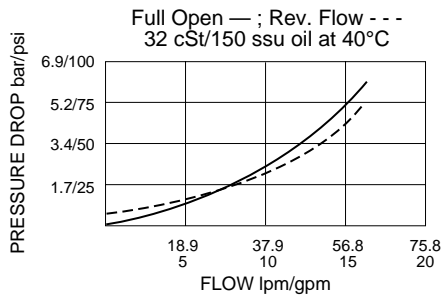

DIMENSIONS

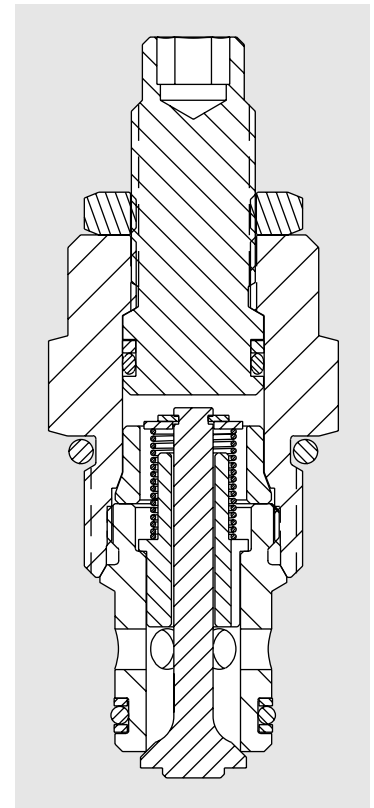
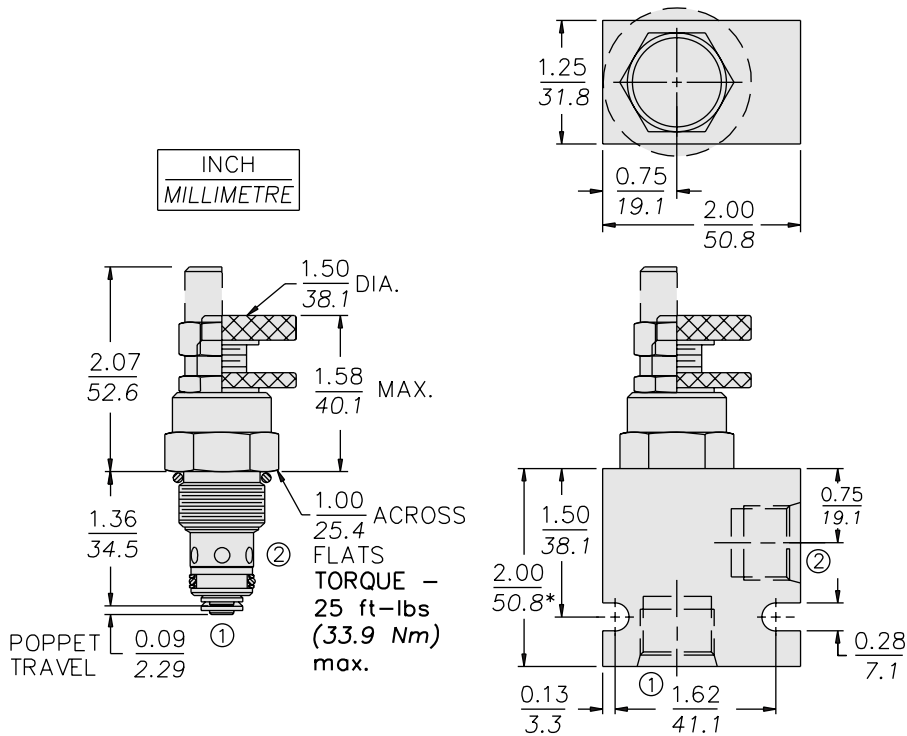

ORIFICE DISCS SHOULD NOT BE USED WITH THIS PRODUCT.

* BSP BODY - 55.9

MATERIALS

Cartridge: Weight: 0.17 kg. (0.37 lbs.)
Steel with hardened work surfaces.
Zinc-plated exposed surfaces.
Buna N O-rings and polyester elastomer back-ups standard.
Anodized aluminum knobs.

Standard Ported Body: Weight: 0.16 kg. (0.35 lbs.). Anodized high-strength 6061 T6 aluminum alloy, rated to 207 bar (3000 psi). Ductile iron bodies available; dimensions may differ. See page 8.010.1

TO ORDER

