

FR12-20F Regulator, Pressure-Compensated

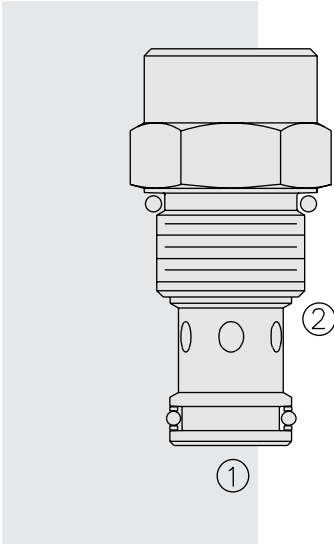

DESCRIPTION

A screw-in, cartridge-style, fixed orifice, pressure-compensated, hydraulic flow regulating valve (restrictive type).

OPERATION

The **FR12-20F** maintains a constant flow rate out of ② regardless of load pressure changes in the circuit downstream of ②.

The fixed control orifice is factory preset to customer flow specification. The valve begins to respond to load changes when the flow through the valve creates a pressure differential across the control orifice greater than 5.5 bar (80 psid), with accurate flow maintenance from 7.6 to 240 bar (110 to 3500 psid). Reverse flow (② to ①) returns through the control orifice and is non-compensated.

FEATURES

- Hardened parts for long life.
- Quiet, modulated response.
- Cost-effective cavity.

RATINGS

Operating Pressure: 240 bar (3500 psi)

Flow Settings: 4 lpm (1 gpm) min; 55 lpm (14.5 gpm) max.

Temperature: -40 to 120°C

Filtration: See page 9.010.1

Fluids: Mineral-based or synthetics with lubricating properties at viscosities of 7.4 to 420 cSt (50 to 2000 sus); See Temperature and Oil Viscosity, page 9.060.1

Installation: No restrictions; See page 9.020.1

Cavity: VC12-2; See page 9.112.1

Cavity Tool: CT12-2XX; See page 8.600.1

Seal Kit: SK12-2X-M; See page 8.650.1

SYMBOLS

USASI:

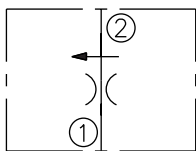

ISO:

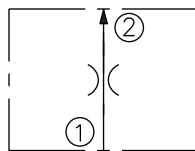

PERFORMANCE

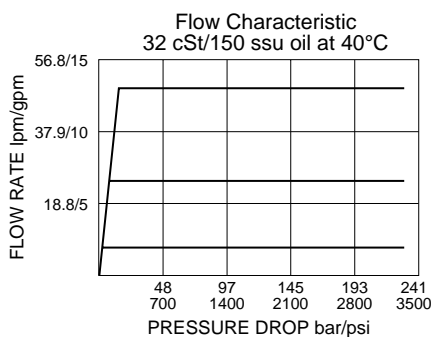

DIMENSIONS

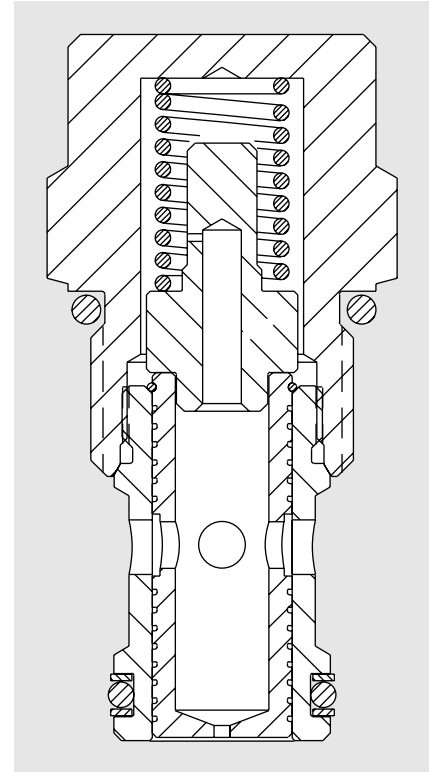
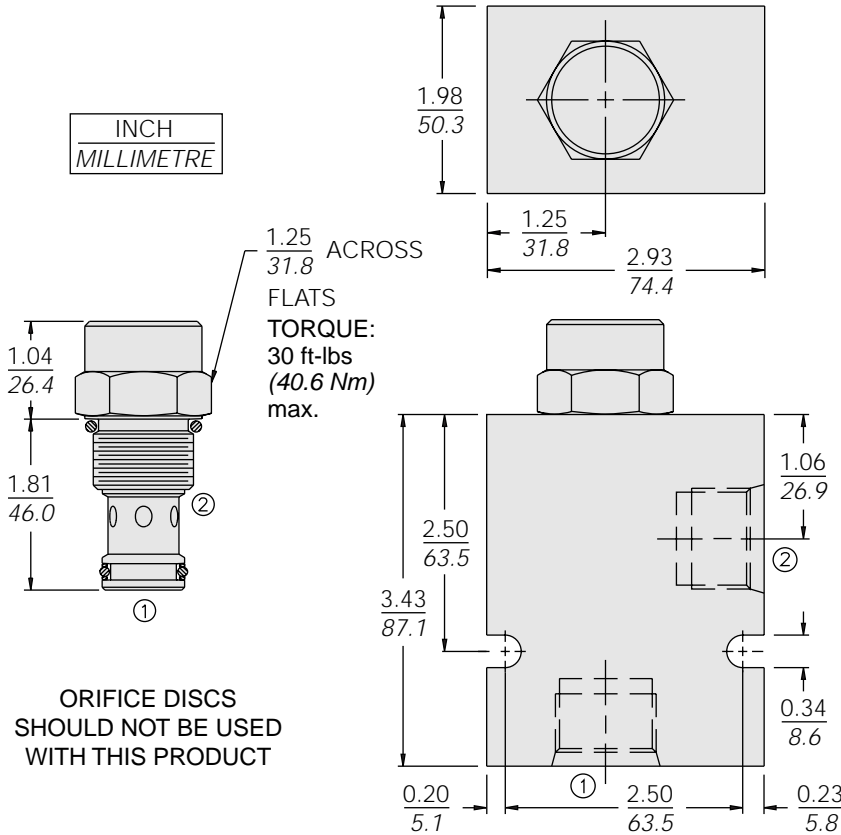

MATERIALS

Cartridge: Weight: 0.08 kg. (0.18 lbs.)
 Steel with hardened work surfaces.
 Zinc-plated exposed surfaces.
 Buna N O-rings and polyester elastomer back-ups standard.

Standard Ported Body: Weight: 0.52 kg. (1.15 lbs.) Anodized high-strength 6061 T6 aluminum alloy, rated to 207 bar (3000 psi). Ductile iron bodies available; dimensions may differ. See page 8.012.1

TO ORDER

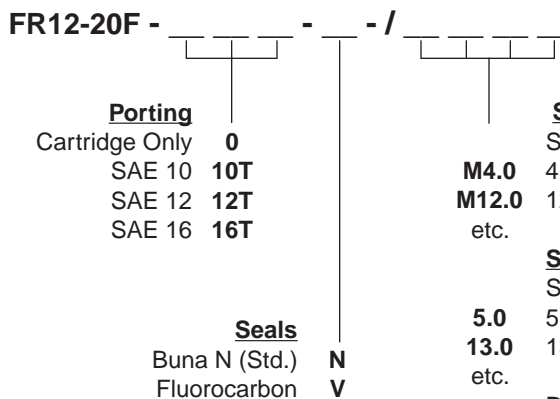

Setting in lpm

Specify, for example:
M4.0 4.0 lpm
M12.0 12.0 lpm
 etc.

Setting in gpm

Specify, for example:
5.0 5.0 gpm
13.0 13.0 gpm
 etc.

Drill Size Method

In thousandths of an inch.
 Specify, for example:

D030 0.030 in. control orifice hole
 etc.

Note: Minimum drill diameter is 0.020 in.
 For smaller orifice sizes consult factory.