

FRRV12-41F Priority Flow Regulator . . .

U.S. Patent
No. 7,063,100

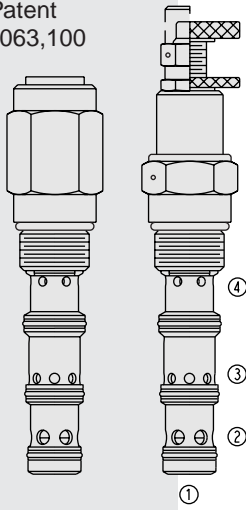

DESCRIPTION

A screw-in, cartridge-style, multi-function valve which includes a fixed-compensated, priority-type flow regulator and an adjustable pressure relief valve in one cartridge.

OPERATION

The **FRRV12-41F** maintains a constant flow rate from port ③ regardless of load pressure changes at priority port ③ or bypass port ②. When load pressure at ③ reaches the setting of the relief valve, flow is dumped over the relief at ④.

The exit flow from the relief can be connected to tank or to the bypass flow.

Note: Back pressure at port ④ is directly additive to the relief setting.

FEATURES

- Two valve functions in one, industry-common cavity.
- Adjustments cannot be backed out of the valve.
- Relief valve adjustments prohibit relief valve spring from going solid.
- Quiet, modulated response.
- Hardened parts for long life.

RATINGS

Maximum Operating Pressure: 207 bar (3000 psi)

Maximum System Pressure: 276 bar (4000 psi)

Priority Flow: 45.4 lpm (12.0 gpm) maximum regulated

Inlet Flow: 75.7 lpm (20.0 gpm) maximum

Relief Valve Pressure Setting Ranges: 17 to 207 bar (250 to 3000 psi)

Temperature: -40 to 120°C with standard Buna seals

Filtration: See page 9.010.1

Fluids: Mineral-based or synthetics with lubricating properties at viscosities of 7.4 to 420 cSt (50 to 2000 sus); See Temperature and Oil Viscosity, page 9.060.1

Installation: No restrictions; See page 9.020.1

Cavity: VC12-4; See page 9.112.1

Cavity Tool: CT12-4XX; See page 8.600.1

Seal Kit: SK12-4X-MMM; See page 8.650.1

SYMBOLS

USASI/ISO:

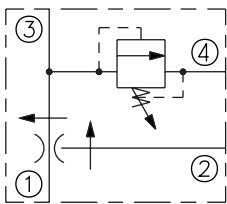

PERFORMANCE (Cartridge Only)

Priority Flow vs. Load Pressure
at 75.7 lpm/20.0 gpm Inlet Flow
32 cSt/150 ssu oil at 40°C

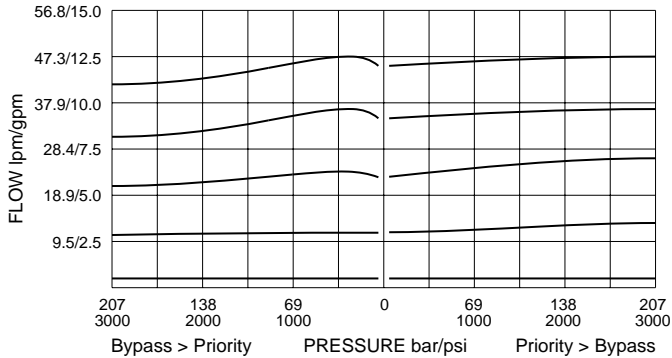

Relief Pressure vs. Flow
32 cSt/150 ssu oil at 40°C

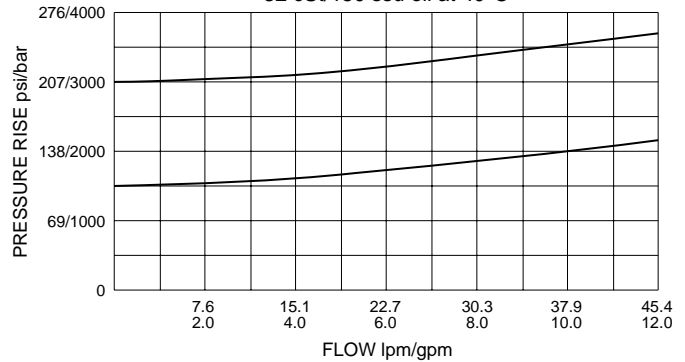

with Built-In Relief Valve

FRRV12-41F

DIMENSIONS

U.S. Patent No. 7,063,100

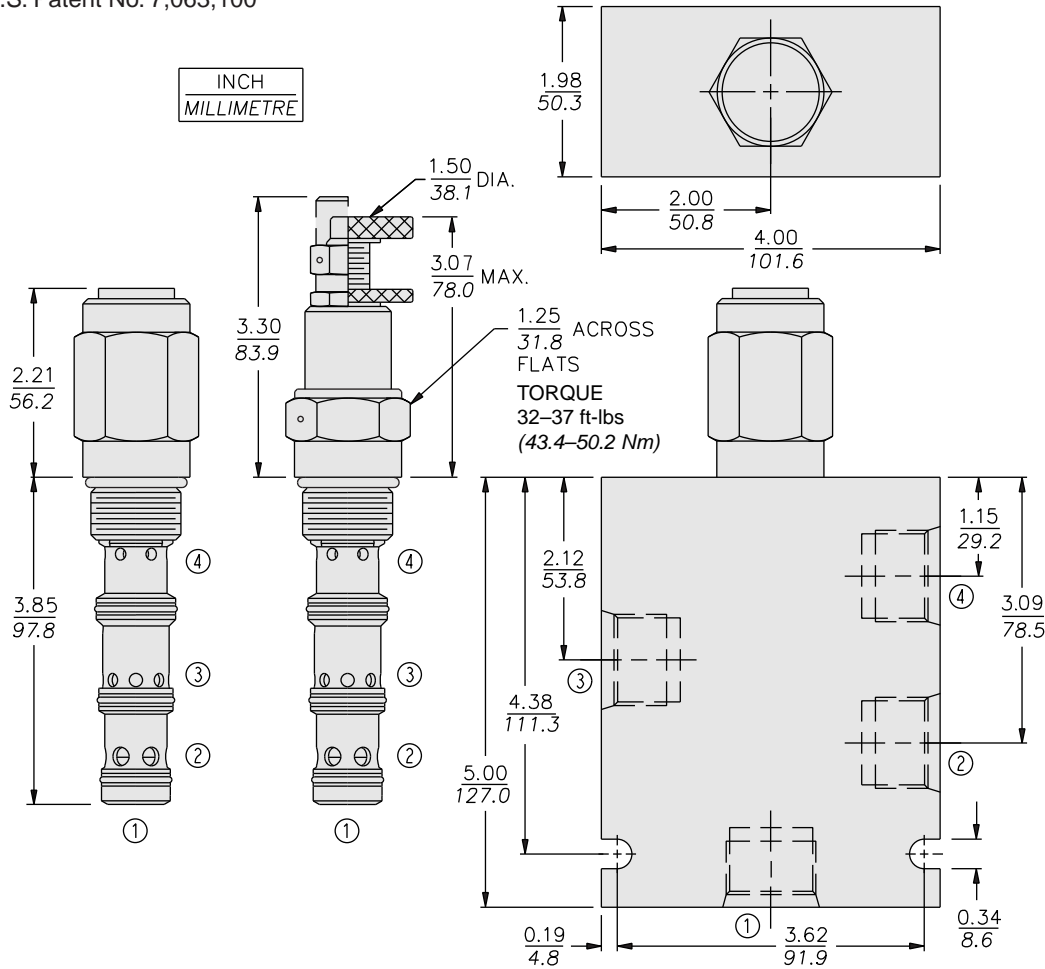

MATERIALS

Cartridge: Weight: 0.43 to 0.48 kg. (0.95 to 1.05 lbs.) depending on option selected. Steel with hardened work surfaces. Zinc-plated exposed surfaces. Buna N O-rings and polyester elastomer back-ups standard. Anodized aluminum knobs and caps.

Standard Ported Body: Weight: 1.50 kg. (3.30 lbs.) Anodized high-strength 6061 T6 aluminum alloy, rated to 207 bar (3000 psi). Ductile iron body required for operation over 207 bar (3000 psi), dimensions may differ. See page 8.010.1

TO ORDER

FRRV12-41F

- Adjustment Option**
 1/4 in. Hex Allen Head **A**
 1-1/2 in. Dia. Alum Knob **B**
 Option A w/Cover Cap **C**
 Factory Preset Non-Adj. **F**
 Factory Preset Hidden Adj. **H**
 Option C w/Lockwire Holes **L**

See page 6.003.1 for adjustment option details.

- Porting**
 Cartridge Only **0**
 SAE 10 **10T**
 SAE 12 **12T**

- Seals**
 Buna N(Std.) **N**
 Fluorocarbon **V**

- Pressure Setting in bar**
 Range: 17 to 207 bar
M25 25 bar (example)
M100 100 bar (example)
- Pressure Setting in psi**
 Range: 250 to 3000 psi
9.0 900 psi (example)
23.5 2350 psi (example)

- Priority Flow Setting**
 Range: 1.0 to 45.4 lpm
M20.0 20.0 lpm (example)
 Range: 0.25 to 12.0 gpm
5.0 5.0 gpm (example)