

EC50-30 Pressure Compensator, High Pressure

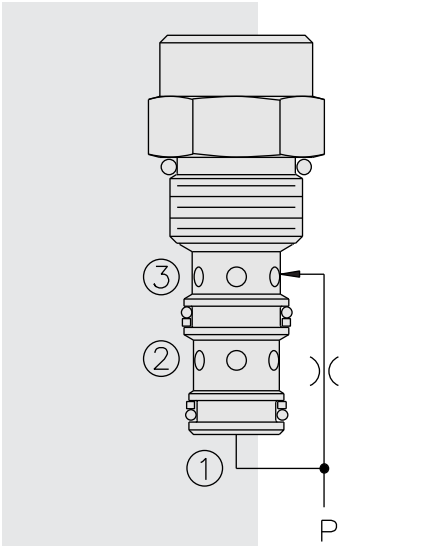

DESCRIPTION

A screw-in, cartridge-style pressure-compensating element, intended for use with a remote fixed or variable orifice to yield a two-port-type, pressure-compensated, flow regulating hydraulic valve for use in high pressure circuits.

OPERATION

The **EC50-30** maintains a constant flow rate from ② regardless of load pressure changes in the circuit downstream of ②.

The cartridge maintains a constant differential pressure from circuit point P to port ③ (see USASI Symbol), thereby regulating the hydraulic flow rate between the two points in the circuit.

FEATURES

- Hardened parts for long life.
- Quiet, modulated response.
- Industry common cavity.

RATINGS

Operating Pressure: 345 bar (5000 psi)

Regulated Flow Rate: 30.3 lpm (8 gpm) max.

Standard Compensator Bias Spring: 5.5 bar (80 psid)

Flow Maintenance: ±10% from 0.38 to 38 lpm (0.1 to 10 gpm) at pressures from 5.5 to 345 bar (80 to 5000 psi)

Temperature: -40 to 120°C

Filtration: See page 9.010.1

Fluids: Mineral-based or synthetics with lubricating properties at viscosities of 7.4 to 420 cSt (50 to 2000 sus); See Temperature and Oil Viscosity, page 9.060.1

Installation: No restrictions; See page 9.020.1

Cavity: VC10-3; See page 9.110.1

Cavity Tool: CT10-3XX; See page 8.600.1

Seal Kit: SK10-3P-TB; See page 8.650.1

SYMBOLS

USASI:

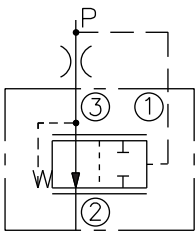

ISO:

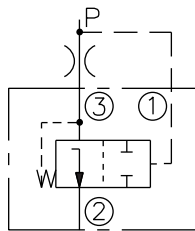

PERFORMANCE (Cartridge Only)

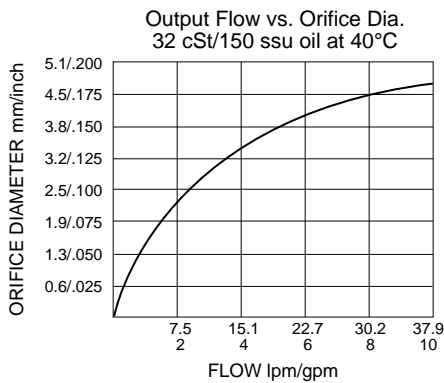

DIMENSIONS

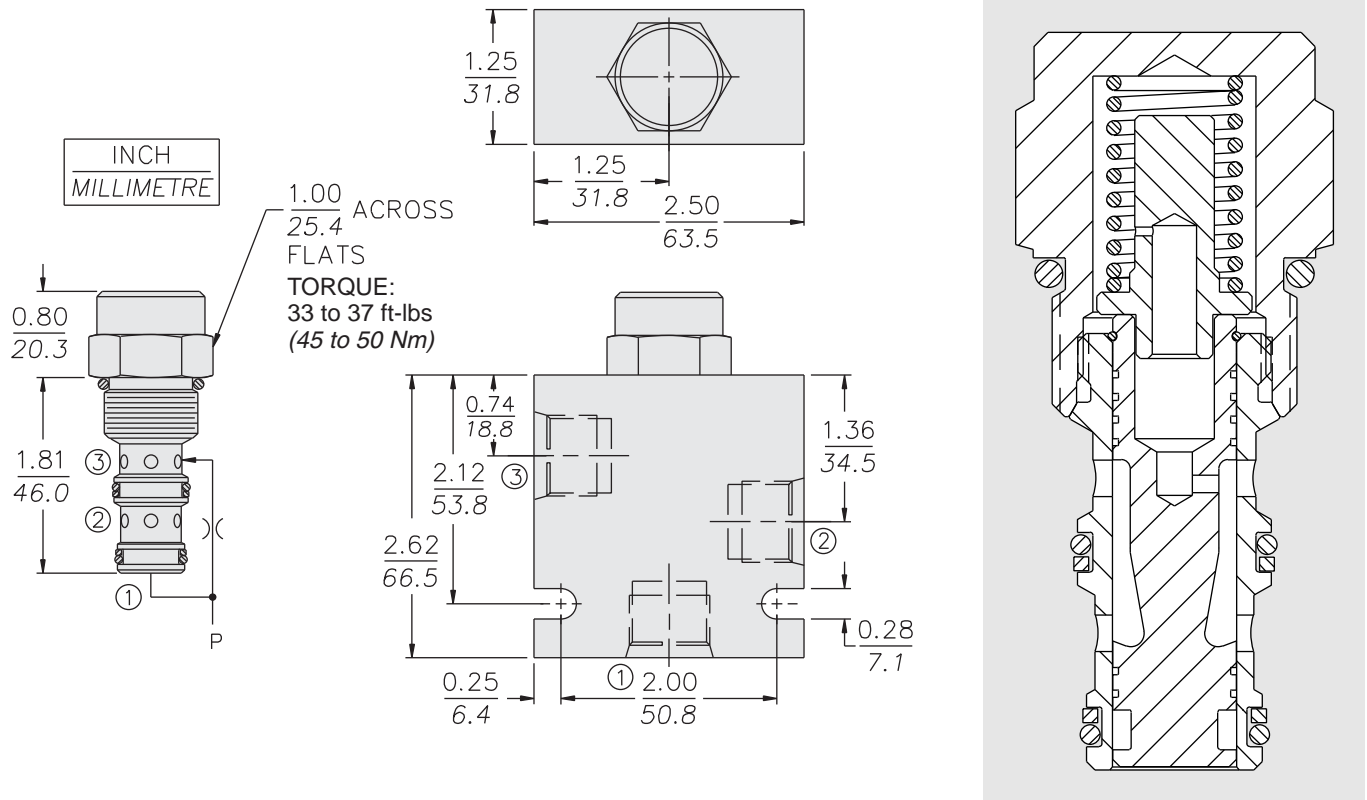

MATERIALS

Cartridge: Weight: 0.11 kg. (0.25 lbs.)
 Steel with hardened work surfaces.
 Zinc-plated exposed surfaces.
 Polyurethane O-rings and
 Fluorocarbon back-ups standard.

Ported Body: Weight: 0.64 kg.
 (1.41 lbs.) Ductile Iron (code "D")
 standard, consult factory for weight,
 dimensions may differ. Rated to
 345 bar (5000 psi).
 See page 8.010.1

TO ORDER

