

EC12-32 Pressure Compensator

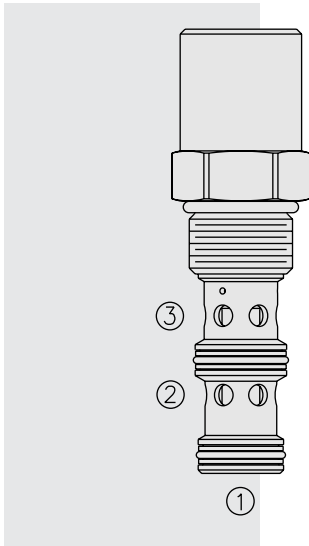

DESCRIPTION

A screw-in, cartridge-style, load sense, flow-on-demand pressure-compensator.

OPERATION

With inlet flow at ②, the **EC12-32** will deliver required flow at ③, in response to load differential pressure sensed at ①.

FEATURES

- Hardened parts for long life.
- Quiet, modulated response.
- Industry common cavity.

RATINGS

Operating Pressure: Inlet: 241 bar (3500 psi)

Maximum Regulated Flow: 57 lpm (15 gpm) with 80 psi compensating spring;
83 lpm (22 gpm) with 160 psi compensating spring.

Flow Maintenance: See performance chart

Temperature: -40 to 120°C with Buna N seals

Filtration: See page 9.010.1

Fluids: Mineral-based or synthetics with lubricating properties at viscosities of 7.4 to 420 cSt (50 to 2000 sus); See Temperature and Oil Viscosity, page 9.060.1

Installation: No restrictions; See page 9.020.1

Cavity: VC12-3; See page 9.112.1

Cavity Tool: CT12-3XX; See page 8.600.1

Seal Kit: SK12-3X-MM; See page 8.650.1

SYMBOLS

USASI/ISO:

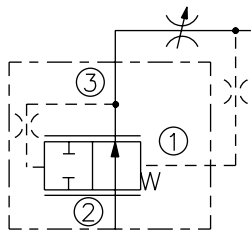

PERFORMANCE (Cartridge Only)

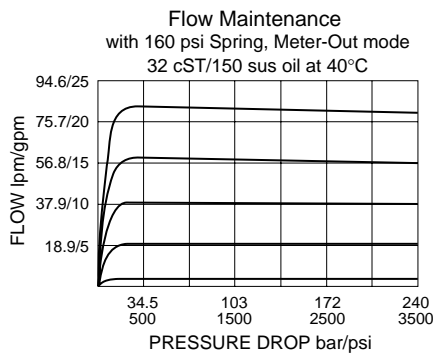

DIMENSIONS

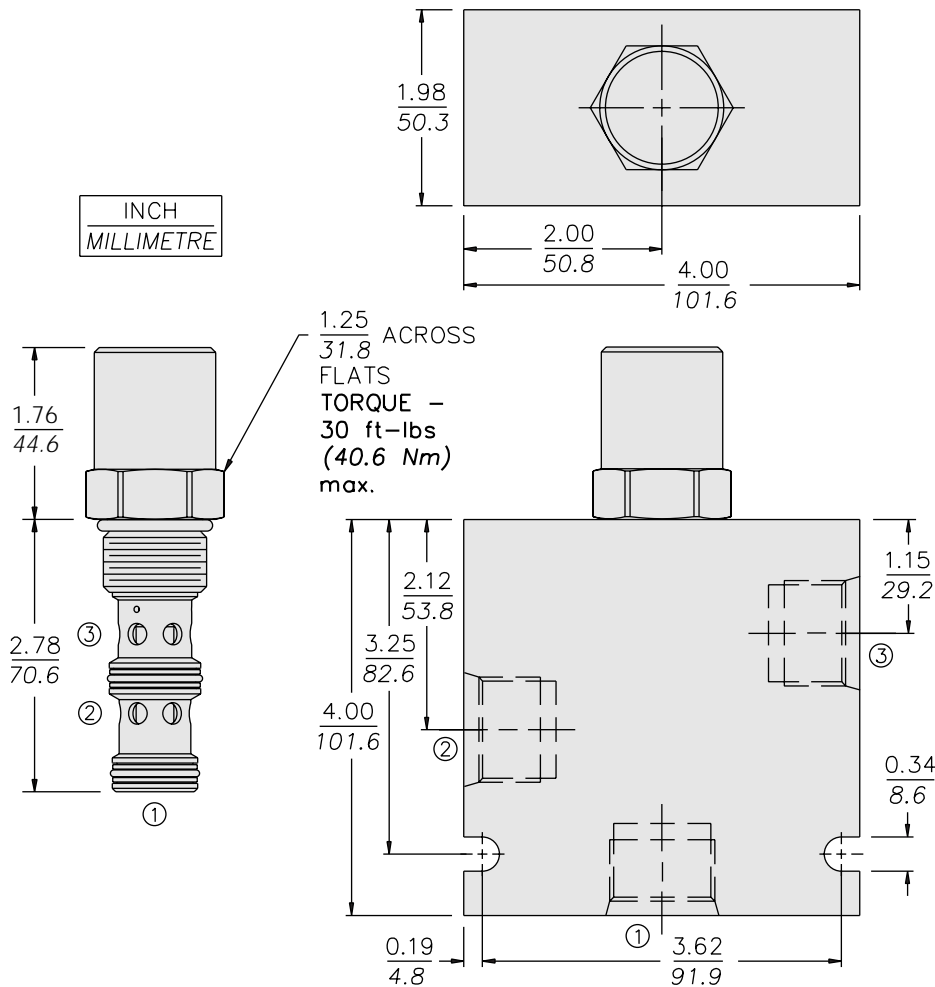

MATERIALS

Cartridge: Weight: 0.39 kg. (0.87 lbs.)
Steel with hardened work surfaces.
Zinc-plated exposed surfaces.
Buna N O-rings and polyester elastomer back-ups standard.

Standard Ported Body: Weight:
1.13 kg. (2.5 lbs.) Anodized high-strength 6061 T6 aluminum alloy, rated to 207 bar (3000 psi). Ductile iron bodies available, dimensions may differ. See page 8.012.1

TO ORDER

