

EC50-40 Pressure Compensator, High Pressure

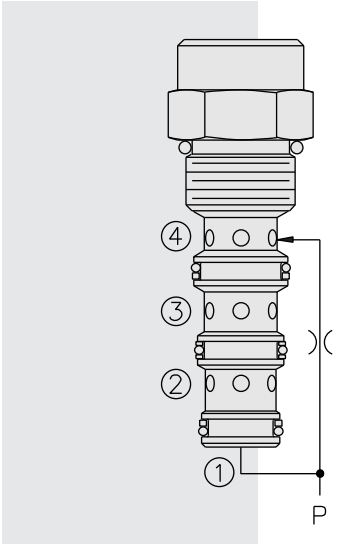

DESCRIPTION

A screw-in, cartridge-style pressure-compensating element, intended for use with a remote fixed or variable orifice to yield a three-port (bypass-type), pressure-compensated, flow regulating hydraulic valve for use in high pressure circuits.

OPERATION

The **EC50-40** maintains a constant flow rate from ③ regardless of load pressure changes in the circuit downstream of ③.

The cartridge maintains a constant differential pressure from circuit point P to port ③ (see USASI Symbol), thereby regulating the hydraulic flow rate between the two points in the circuit. The EC50-40 is a priority type regulator, delivering pump flow first to ③, then bypassing excess to ②. All ports may be fully pressurized.

FEATURES

- Hardened parts for long life.
- Quiet, modulated response.
- Industry common cavity.

RATINGS

Operating Pressure: 345 bar (5000 psi)

Flow Rate: 38 lpm (10 gpm) max. regulated; 57 lpm (15 gpm) max. input.

EC50-40 inlet pressure begins to rise over compensating pressure when bypass oil exceeds 26 lpm (7 gpm).

Standard Compensator Bias Spring: 5.5 bar (80 psid)

Flow Maintenance: 0.38 to 1.86 lpm (0.1 to 0.49 gpm) settings $\pm 20\%$;

1.89 to 5.64 lpm (0.5 to 1.49 gpm) settings $\pm 15\%$;

5.68 to 37.85 lpm (1.5 to 10 gpm) settings $\pm 10\%$

Temperature: -40 to 120°C

Filtration: See page 9.010.1

Fluids: Mineral-based or synthetics with lubricating properties at viscosities of

7.4 to 420 cSt (50 to 2000 sus); See Temperature and Oil Viscosity, page 9.060.1

Installation: No restrictions; See page 9.020.1

Cavity: VC10-4; See page 9.110.1

Cavity Tool: CT10-4XX; See page 8.600.1

Seal Kit: SK10-4P-TMB; See page 8.650.1

SYMBOLS

USASI/ISO:

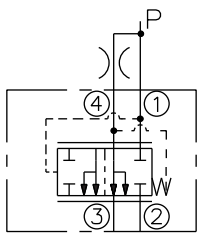

PERFORMANCE (Cartridge Only)

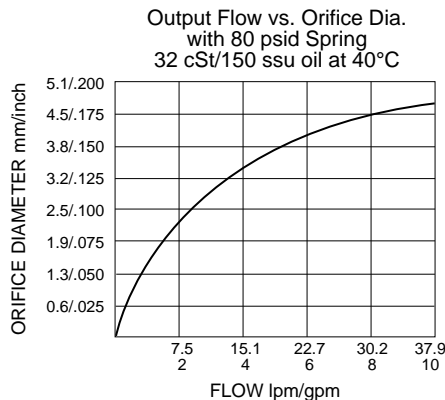

DIMENSIONS

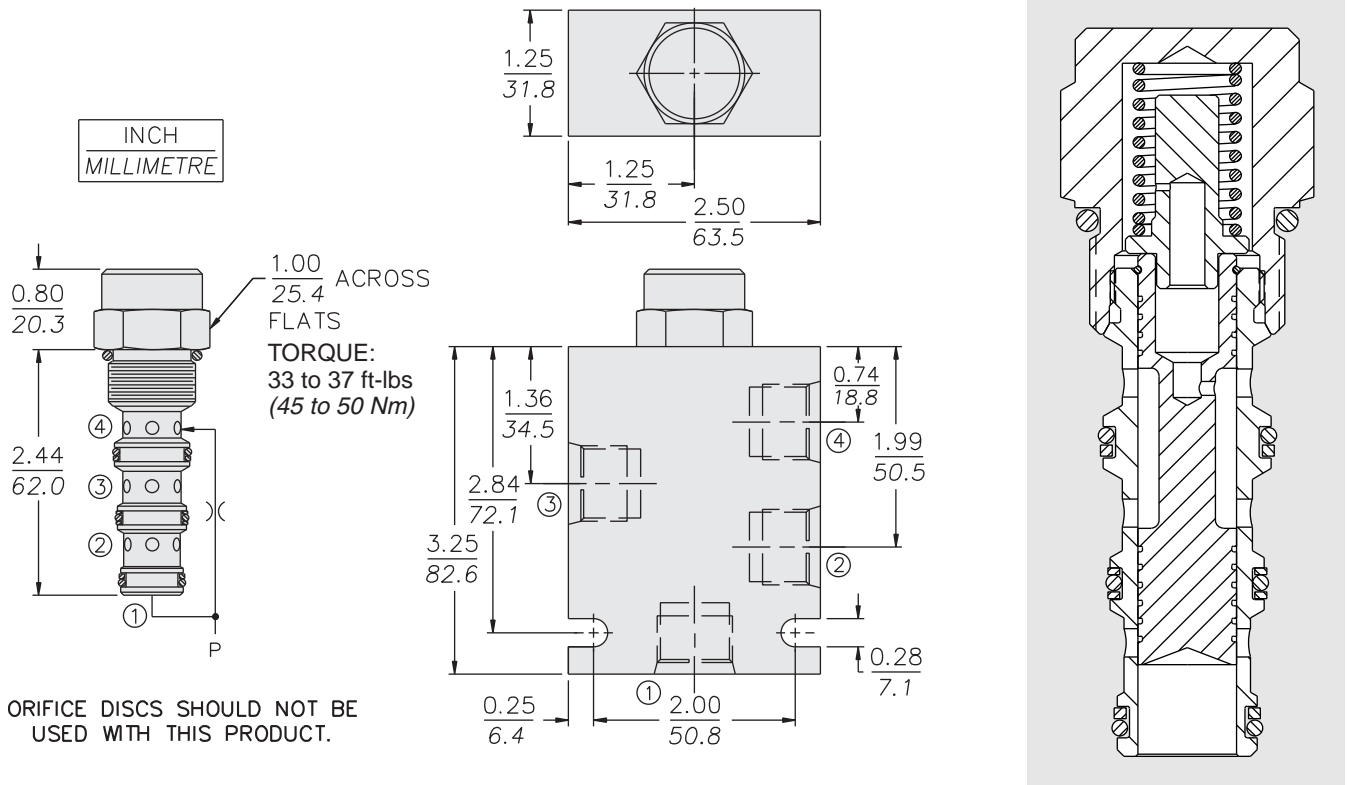

ORIFICE DISCS SHOULD NOT BE USED WITH THIS PRODUCT.

MATERIALS

Cartridge: Weight: 0.18 kg. (0.39 lbs.)
Steel with hardened work surfaces.
Zinc-plated exposed surfaces.
Polyurethane O-rings and
Fluorocarbon back-ups standard.

Ported Body: Weight: 0.68 kg.
(1.51 lbs.); Ductile Iron (code "D")
standard, consult factory for weight,
dimensions may differ. Rated to
345 bar (5000 psi).
See page 8.010.1.

TO ORDER

