

# EC16-40 Pressure Compensator

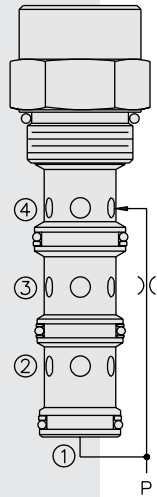

## DESCRIPTION

A screw-in, cartridge-style pressure-compensating element, intended for use with a remote fixed or variable orifice to yield a three-port (bypass-type), pressure-compensated, flow regulating hydraulic valve.

## OPERATION

The **EC16-40** maintains a constant flow rate from ③ regardless of load pressure changes in the circuit downstream of ③.

The cartridge maintains a constant differential pressure from circuit point P to port ③ (see USASI Symbol), thereby regulating the hydraulic flow rate between the two points in the circuit. The EC16-40 is a priority type regulator, delivering pump flow first to ③, then bypassing excess to ②. All ports may be fully pressurized.

## FEATURES

- Hardened parts for long life.
- Quiet, modulated response.
- Industry common cavity.

## RATINGS

**Operating Pressure:** 240 bar (3500 psi)

**Flow Rate:** 100 lpm (26.5 gpm) max. regulated; 180 lpm (47.5 gpm) max. input.

Pressure at ① begins to rise higher than compensating pressure differential when bypass flow exceeds 80 lpm (21 gpm).

**Standard Compensator Bias Spring:** 5.5 bar (80 psid)

**Flow Maintenance:** 7.57 to 98.4 lpm (2 to 26 gpm) settings  $\pm 10\%$

**Temperature:** -40 to 120°C

**Filtration:** See page 9.010.1

**Fluids:** Mineral-based or synthetics with lubricating properties at viscosities of 7.4 to 420 cSt (50 to 2000 sus); See Temperature and Oil Viscosity, page 9.060.1

**Installation:** No restrictions; See page 9.020.1

**Cavity:** VC16-4; See page 9.116.2

**Cavity Tool:** CT16-4XX; See page 8.600.1

**Seal Kit:** SK16-4X-TMB; See page 8.650.1

## SYMBOLS

### USASI/ISO:

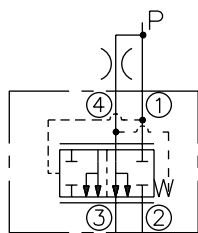

## PERFORMANCE (Cartridge Only)

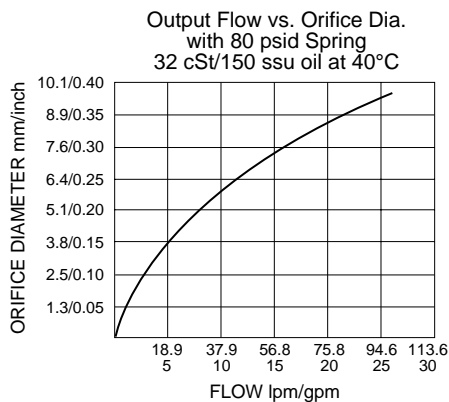

## DIMENSIONS

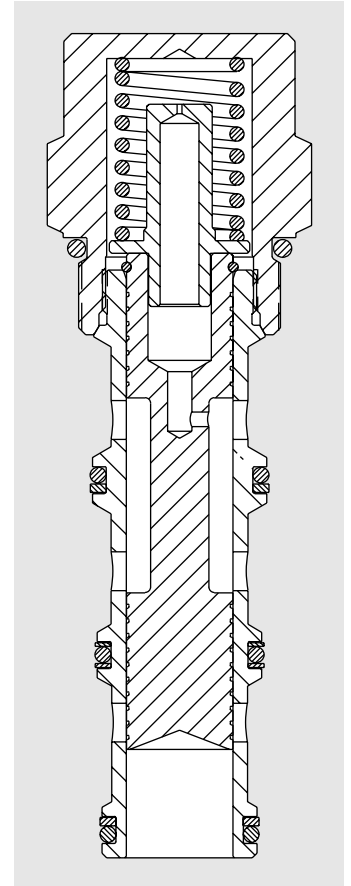
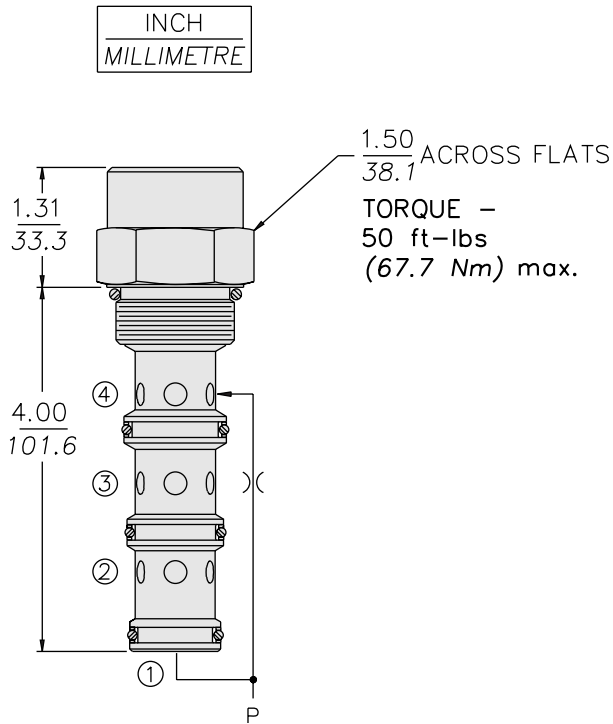

## MATERIALS

**Cartridge:** Weight: 0.36 kg. (0.80 lbs.)  
Steel with hardened work surfaces.  
Zinc-plated exposed surfaces.  
Buna N O-rings and polyester elastomer back-ups standard.

**Ported Body:** Not available; consult factory.

## TO ORDER

