

EC50-42 Pressure Compensator, High Pressure

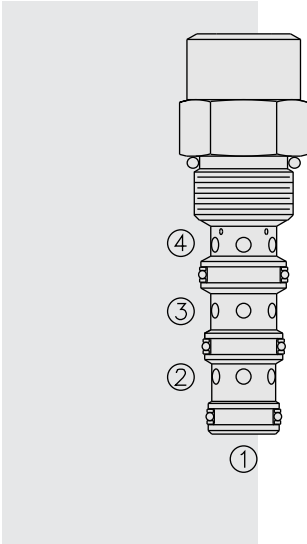

DESCRIPTION

A screw-in, cartridge-style, priority-on-demand, pressure-compensator with a static load sense, intended to provide priority flow in the required amount, while allowing excess flow to be used for auxiliary functions.

OPERATION

With inlet flow at ③, the **EC50-42** will deliver required priority flow at ④, regardless of load pressure. Excess flow exits at ②. Port ① is the load sense port. All ports may be fully pressurized.

FEATURES

- Hardened parts for long life.
- Quiet, modulated response.
- Industry common cavity.

RATINGS

Operating Pressure: Inlet: 345 bar (5000 psi)

Input Flow Rate: 45.4 lpm (12 gpm) maximum

Maximum Regulated Flow: 37.9 lpm (10 gpm) with 10.3 bar (150 psi) compensator spring; 30.2 lpm (8.0 gpm) with 5.5 bar (80 psi) compensator spring

Flow Maintenance: see performance chart

Temperature: -40 to 120°C

Filtration: See page 9.010.1

Fluids: Mineral-based or synthetics with lubricating properties at viscosities of 7.4 to 420 cSt (50 to 2000 sus); See Temperature and Oil Viscosity, page 9.060.1

Installation: No restrictions; See page 9.020.1

Cavity: VC10-4; See page 9.110.1

Cavity Tool: CT10-4-XXX; See page 8.600.1

Seal Kit: SK10-4P-TMB; See page 8.650.1

SYMBOLS

USASI/ISO:

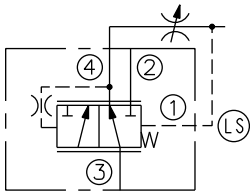

PERFORMANCE (Cartridge Only)

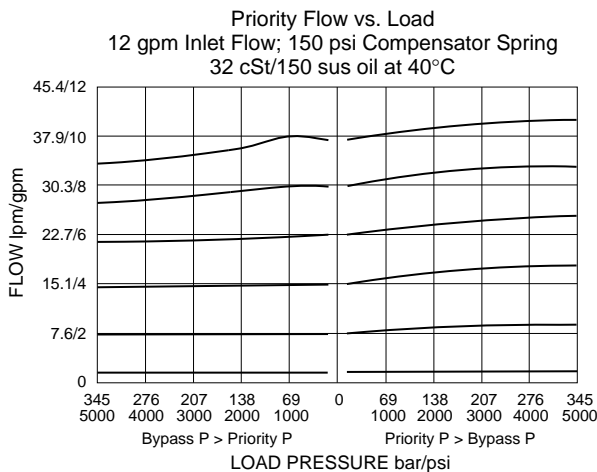

with Static Load Sense

EC50-42

DIMENSIONS

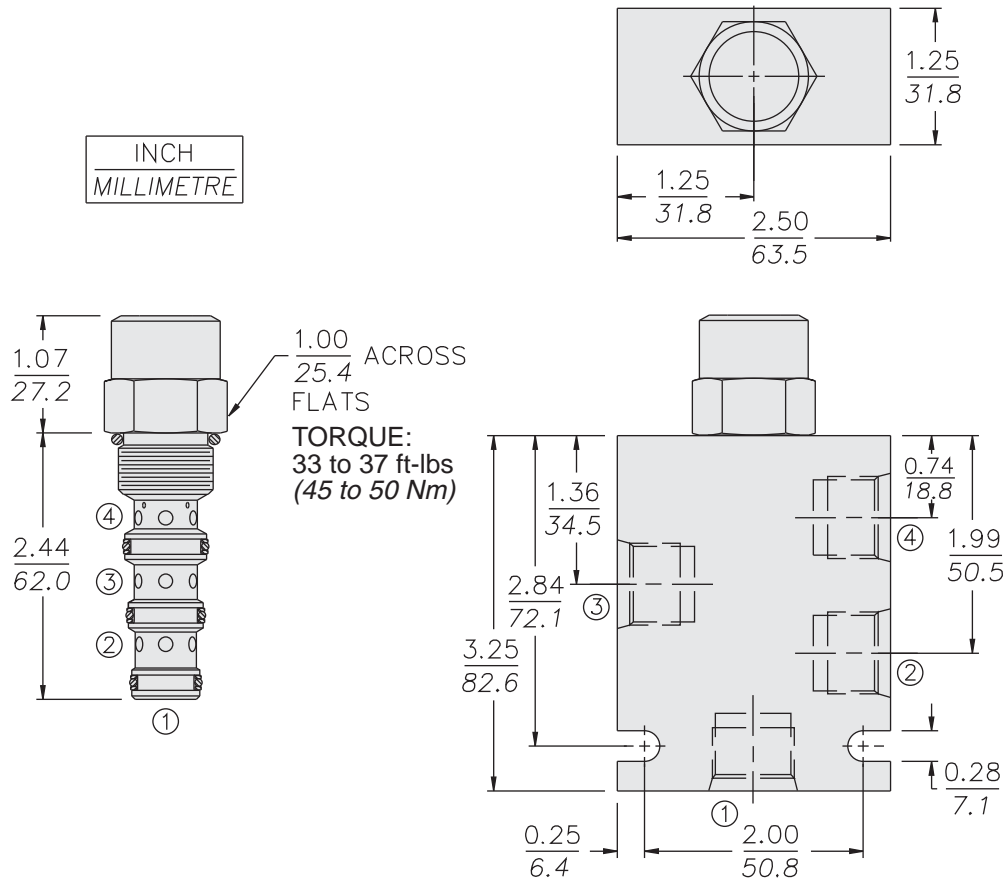

MATERIALS

Cartridge: Weight: 0.17 kg. (0.37 lbs.)
Steel with hardened work surfaces.
Zinc-plated exposed surfaces.
Buna N O-rings and polyester elastomer back-ups standard.

Ported Body: Weight: 0.68 kg. (1.51 lbs.) Ductile Iron (code "D") standard, consult factory for weight, dimensions may differ. Rated to 345 bar (5000 psi). See page 8.010.1.

TO ORDER

