

# EC42-M42 Pressure Compensator

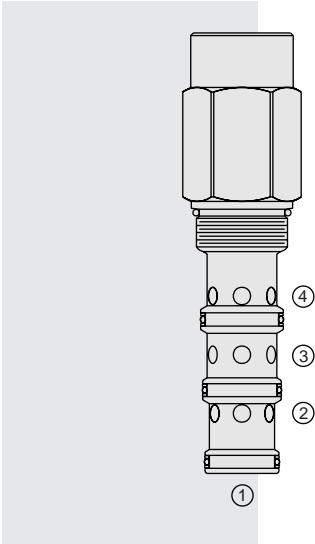

## DESCRIPTION

A screw-in, cartridge-style priority-on-demand pressure-compensator with static load sense.

## OPERATION

The **EC42-M42** provides priority flow in the required amount, while allowing excess flow to be used for auxiliary functions. With port ③ providing inlet flow, port ④ will deliver the required priority flow regardless of load pressure. Excess flow exits at ②. Port ① is the load sense port. All ports may be fully pressurized.

**NOTE:** 0.031 in. (0.79 mm) orifice is recommended to be installed in the load sense line at port ① for better stability.

## FEATURES

- Hardened parts for long life.
- Quiet, modulated response.
- Industry common cavity.

## RATINGS

**Operating Pressure:** 241 bar (3500 psi)

**Maximum Input Flow:** 303 lpm (80.0 gpm)

**Maximum Priority Flow:** 208 lpm (55.0 gpm) with 10.3 bar (150 psi) spring;  
151 lpm (40.0 gpm) with 5.5 bar (80 psi) spring

**Maximum Bypass Flow:** 208 lpm (55.0 gpm) with 10.3 bar (150 psi) spring;  
151 lpm (40.0 gpm) with 5.5 bar (80 psi) spring

**Flow Maintenance:** see performance chart

**Temperature:** -40 to 120°C with Buna N seals

**Filtration:** See page 9.010.1

**Fluids:** Mineral-based or synthetics with lubricating properties at viscosities of 7.4 to 420 cSt (50 to 2000 sus); See Temperature and Oil Viscosity, page 9.060.1

**Installation:** No restrictions; See page 9.020.1

**Cavity:** VC42-M4; See page 9.142.1

**Cavity Tool:** CT42-M4XX; See page 8.600.1

**Seal Kit:** SK42-4X-MMM; See page 8.650.1

## SYMBOLS

### USASI/ISO:

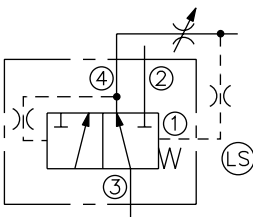

## PERFORMANCE (Cartridge Only)

Pressure Drop thru Bypass vs. Inlet Flow  
with ④ closed; no load at ②  
0.031 in. (0.79 mm) Orifice  
in Load Sense Line  
32 cSt/150 sus oil at 40°C

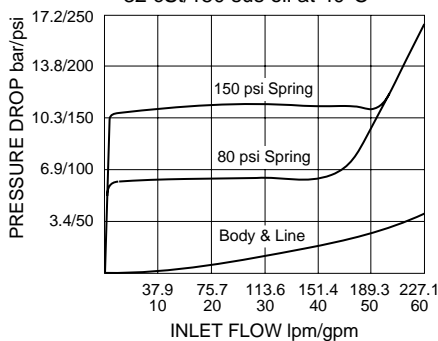

Priority Flow vs. Pressure  
at 3500 psi (241 bar), 60 gpm (227 lpm) Inlet  
0.031 in. (0.79 mm) Orifice in Load Sense Line  
150 psi Spring: —; 80 psi Spring: - - - -  
32 cSt/150 sus oil at 40°C

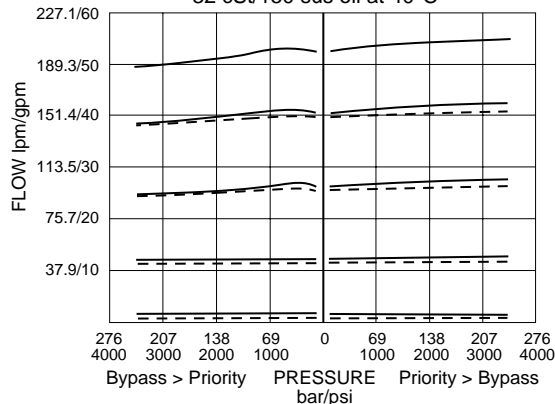

**DIMENSIONS**

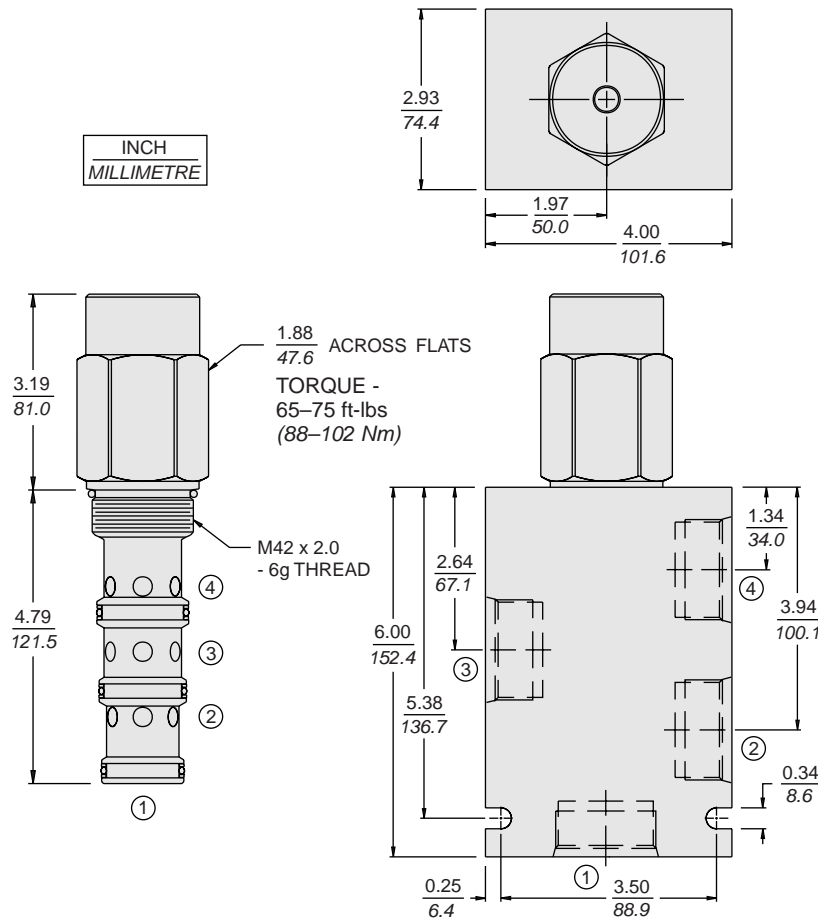

**MATERIALS**

**Cartridge:** Weight: 1.56 kg. (3.44 lbs.)  
Steel with hardened work surfaces.  
Zinc-plated exposed surfaces.  
Buna N O-rings and polyester elastomer back-ups standard.

**Standard Ported Body:** Weight: 2.8 kg. (6.2 lbs.)  
Anodized high-strength 6061 T6 aluminum alloy, rated to 207 bar (3000 psi). Ductile iron bodies available; dimensions may differ. See page 8.042.1.

**TO ORDER**

