

FD12-41 Flow Divider/Combiner, Cylinder Synch.

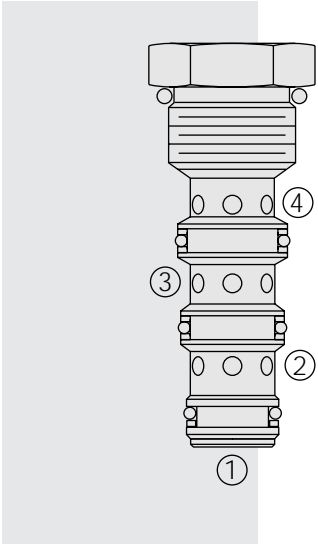

DESCRIPTION

A screw-in, cartridge-style, spool-type flow divider/combiner. Optional flow dividing/combining ratios are maintained regardless of system operating pressure conditions.

OPERATION

In the dividing mode, the **FD12-41** will divert input flow from port ③ to ports ② and ④, based on the ratio specified, regardless of operating pressure.

The cartridge will combine input flows from ports ② and ④.

The **FD12-41** is designed to allow flow to the opposite cylinder once the first cylinder has "bottomed" in the combining mode.

FEATURES

- Hardened parts for long life.
- Quiet, modulated response.

RATINGS

Operating Pressure: 240 bar (3500 psi)

Flow: 90.8 lpm (24 gpm) input max.

Flow Options:

Input Flow: 60.6 lpm (16 gpm); Ratio: 50:50; Model Code: 44

Input Flow: 75.7 lpm (20 gpm); Ratio: 50:50; Model Code: 55

Input Flow: 90.8 lpm (24 gpm); Ratio: 50:50; Model Code: 66

Standard Compensator Bias Spring: 2.07 bar (30 psid)

Flow Accuracy: 10% from 30–100% of rated flow

Temperature: -40 to 120°C

Filtration: See page 9.010.1

Fluids: Mineral-based or synthetics with lubricating properties at viscosities of 7.4 to 420 cSt (50 to 2000 sus); See Temperature and Oil Viscosity, page 9.060.1

Installation: No restrictions; See page 9.020.1

Note: Standard 12 size 4-way bodies should not be used with this product.

See page 8.012.3 for special flow divider bodies.

Cavity: VC12-4; See page 9.112.1 (Cavity Variation "A")

Cavity Tool: CT12-4XX; See page 8.600.1

Seal Kit: SK12-4X-MMM; See page 8.650.1

SYMBOLS

USASI/ISO:

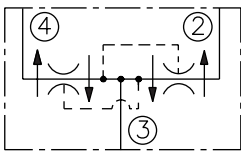

PERFORMANCE (Cartridge Only)

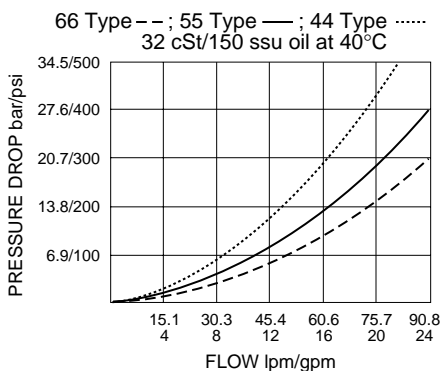

Note: This model will be superseded by the new FDxx-45 models, which incorporate the features of the FDxx-40, FDxx-41 and FDxx-42 series valves in one product. OEM's are encouraged to consider the newer, more robust and versatile FDxx-45 models for new applications:

FD50-45; see page 5.632.1
 FD52-45; see page 5.634.1
 FD56-45; see page 5.636.1

DIMENSIONS

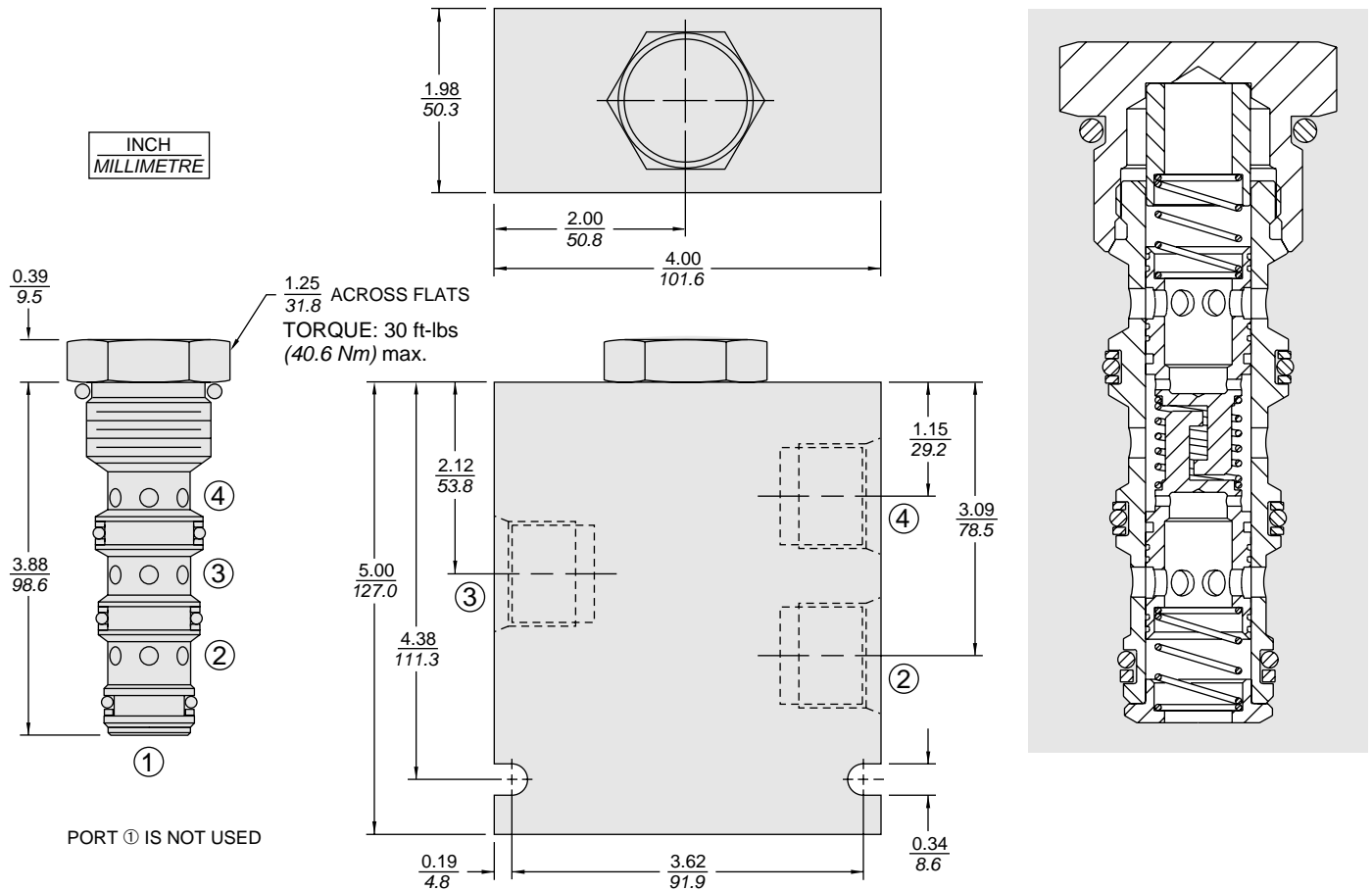

MATERIALS

Cartridge: Weight: 0.28 kg. (0.61 lbs.)
Steel with hardened work surfaces.
Zinc-plated exposed surfaces.
Buna N O-rings and polyester elastomer back-ups standard.

Standard Ported Body: Weight:
1.50 kg. (3.30 lbs.) Anodized high-strength 6061 T6 aluminum alloy, rated to 207 bar (3000 psi). Ductile iron bodies available; dimensions may differ. See page 8.012.1

TO ORDER

FD12-41 - - -

Porting

- Cartridge Only **0**
- SAE 10 **10T**
- SAE 12 **12T**
- See page 8.012.3 **8D**
- See page 8.012.3 **10D**

Flow Options (50/50 Ratio)

- 44** 16 gpm (60 lpm)
- 55** 20 gpm (74 lpm)
- 66** 24 gpm (90 lpm)

Consult factory for other flow options.

NOTE: Standard 12-size 4-way bodies should not be used for flow dividers. See special flow divider bodies, page 8.012.1

Seals

- N** Buna N (Std.)
- V** Fluorocarbon