

FD16-42 Flow Divider/Combiner, w/Anti-Stall Feature

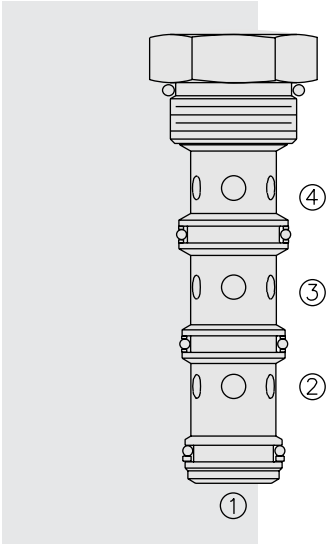

DESCRIPTION

A screw-in, cartridge-style, spool-type flow divider/combiner. Standard flow dividing/combining ratios are maintained regardless of system operating pressure conditions.

OPERATION

In the dividing mode, the **FD16-42** will divert input flow from port ③ to ports ② and ④, based on the ratio specified, regardless of operating pressure.

The cartridge will combine input flows from both ② and ④.

The FD16-42 is designed to maintain a flow path to both combining ports ② and ④ when one port is "free-wheeling." This feature keeps hydraulic (parallel) motor drive circuits from stalling in the combining mode only.

FEATURES

- Hardened parts for long life.
- Quiet, modulated response.
- Industry common cavity.

RATINGS

Operating Pressure: 240 bar (3500 psi)

Flow: See Performance Chart

Flow Options:

Input Flow: 98.4 lpm (26 gpm); Ratio: 50:50; Model Code: 44

Input Flow: 151.4 lpm (40 gpm); Ratio: 50:50; Model Code: 66

Other ratio options available; consult factory.

Standard Compensator Bias Spring: 2.07 bar (30 psid)

Flow Accuracy: 10% from 33-100% of rated flow

Temperature: -40 to 120°C

Filtration: See page 9.010.1

Fluids: Mineral-based or synthetics with lubricating properties at viscosities of

7.4 to 420 cSt (50 to 2000 sus); See Temperature and Oil Viscosity, page 9.060.1

Installation: No restrictions; See page 9.020.1

Note that standard 16 size 4-way bodies should not be used with this product.

See page 8.016.1 for special flow divider bodies.

Cavity: VC16-4; See page 9.116.2

Cavity Tool: CT16-4XX; See page 8.600.1

Seal Kit: SK16-4X-MMM; See page 8.650.1

SYMBOLS

USASI/ISO:

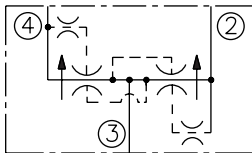

PERFORMANCE (Cartridge Only)

③ to ② or ④: 44 Type — ;
66 Type - - -
32 cSt/150 ssu oil at 40°C

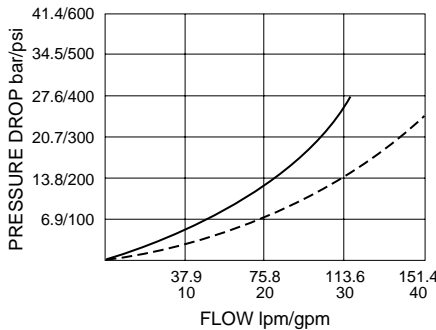

Note: This model will be superseded by the new FDxx-45 models, which incorporate the features of the FDxx-40, FDxx-41 and FDxx-42 series valves in one product. OEM's are encouraged to consider the newer, more robust and versatile FDxx-45 models for new applications:

FD50-45; see page 5.632.1
 FD52-45; see page 5.634.1
 FD56-45; see page 5.636.1

DIMENSIONS

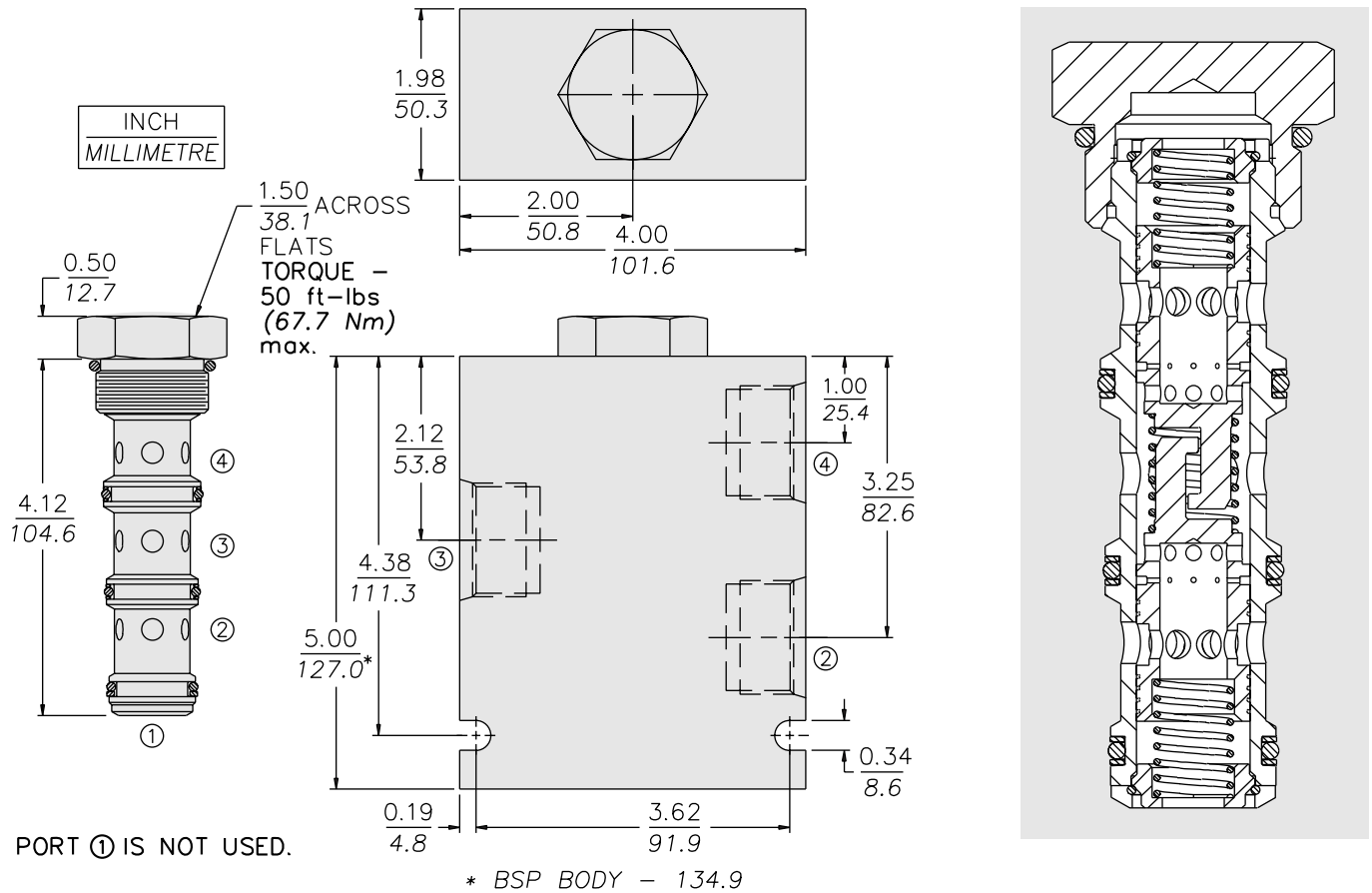

MATERIALS

Cartridge: Weight: 0.36 kg. (0.80 lbs.)
Steel with hardened work surfaces.
Zinc-plated exposed surfaces.
Buna N O-rings and polyester
elastomer back-ups standard.

Special Ported Body: Weight: 1.5 kg.
(3.3 lbs.) Anodized high-strength
6061 T6 aluminum alloy, rated to
207 bar (3000 psi). Ductile iron
bodies available; dimensions
may differ. See page 8.016.1

TO ORDER

FD16-42 -

Special Ported Bodies

- Cartridge Only **0**
- SAE 12 (All Ports) **12T**
- SAE 12 ② & ④;
SAE 16 ③ **16D**
- SAE 16 (All Ports) **16T**
- 3/4 in. BSP* (All Ports) **6B**
- 3/4 in. BSP* ② & ④;
1 in. BSP* ③ **7B**
- 1 in. BSP* (All Ports) **8B**

*BSP Body; U.K. Mfr. Only

Dividing/Combining Ratio

- 44** 50:50 rated @ 98.4 lpm
(26 gpm) input
- 66** 50:50 rated @ 151.4 lpm
(40 gpm) input

NOTE: Additional ratios and/or input
flow sizings available for OEM
applications. Consult factory.

Seals

- N** Buna N (Std.)
- V** Fluorocarbon

NOTE: Standard 16-size 4-way bodies should
not be used for flow dividers. See special flow
divider bodies, page 8.016.1.