

••••• **INNOVATION AT WORK FOR YOU** •••••

New solenoid-operated valve with built-in reverse-flow check can reduce system cost

New SVCV08-20 and SVCV08-21 dual-function valves can help reduce costs in medium flow applications that require low leakage. They are solenoid-operated, two-way, pilot-operated valves with outlet flow check. As poppet-type valves, the SVCVs are well-suited for load-holding or blocking applications. And being uni-directional, they are ideal for single-acting cylinder applications. They are rated for flows up to 6 gpm/22.7 lpm, with an impressive low-leakage rate of 5 dpm between ports 2 to 1, and 10 dpm from ports 1 to 2 at rated pressure. The pressure drop is 74 psi/ 5.1 bar for the rated flow, so there is little heat build-up or energy loss.



With conventional single-function valves, both an 08-size solenoid valve and a separate reverse flow check valve would have been required to achieve the same functionality. By using one cartridge instead of two, initial cost, cavity machining costs, and the size and weight of the manifold can all be reduced.

Although the SVCVs are 2-way valves, they require a 3-way cavity, with the normal inlet at cavity port 3 (valve port 2) and with the outlet at cavity ports 1 and 2 blocked. However, cavity port 2 can be connected as an alternate outlet port, though the pressure drop will be significantly higher from ports 3 to 2. This feature offers manifold design and application flexibility.

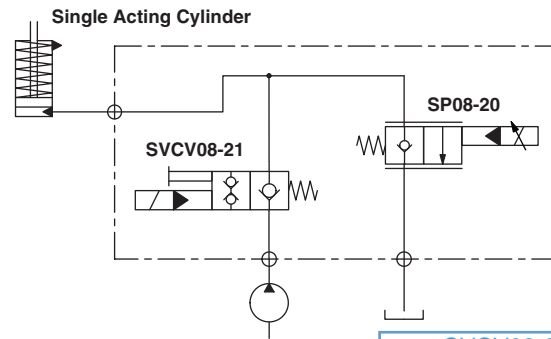
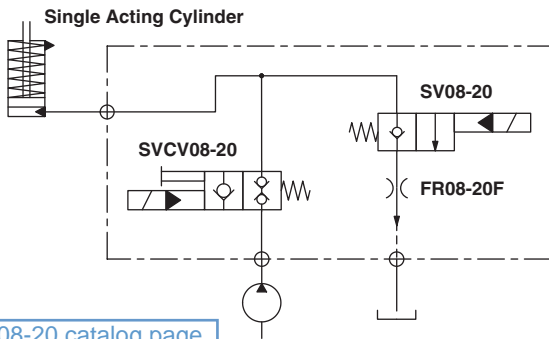

[go to SVCV08-20 catalog page](#)

[go to SVCV08-21 catalog page](#)

Features	Benefits
Compact, multi-function solenoid valve with integral outlet-flow check.	Dual functionality allows lower cost, smaller packaging and lighter-weight manifolds.
Industry common cavity.	Easy manifold machining using standard tooling and set-up configurations.
Poppet-style construction.	Suitable for load-holding applications.
New manual-override options.	SVCV08-20 has 'M' Manual override option. SVCV08-21 has 'P' and 'K' option.
Optional waterproof E-Coils rated up to IP69K.	Reliability in the harshest, most severe operating conditions.
Hardened seat for long life and low leakage.	Reliable operation in mobile machinery application conditions.
5-year limited warranty. See full warranty statement in the catalog or website.	Confidence, with the backing of the industry's leading manufacturer of hydraulic cartridge valves
Tested to 1 million cycles at max. rated flow and pressure.	Long life without wear or decreased performance over time.

HydraForce is dedicated to innovation, quality and superior technical support in order to provide our customers with the most competitive high-performance system solutions in the industry. Please see www.hydraforce.com for additional product information, or contact your HydraForce representative for assistance.

Disclaimer: Nothing in this document constitutes an implied warranty of merchantability or of fitness for a particular purpose. The information contained in this document is provided for technical illustration purposes only and may not be used as a statement of suitability for use in any particular application. Each application is unique and prospective purchasers should conduct their own tests and studies to determine the fitness of HydraForce's products for their particular purposes and specific applications.

HYDRAFORCE, INC.

500 Barclay Blvd. • Lincolnshire, IL 60069 USA
 Ph: 847 793 2300 • Fx: 847 793 0086
 Web: www.hydraforce.com • E-Mail: sales@hydraforce.com
 ISO 9001 & QS 9000 • Member: National Fluid Power Assn.

HYDRAFORCE HYDRAULICS, LTD.

St. Stephens Street • Birmingham B6 4RG England
 Ph: 0121 333 1800 • Fx: 0121 333 1810
 Web: www.hydraforce.com • E-Mail: sales@hydraforce.com
 ISO 9001 & ISO 14001 • Member: British Fluid Power Assn.