

RV50-26 Relief, Pilot-Operated Spool

U.S. Patent
No. 7,137,406

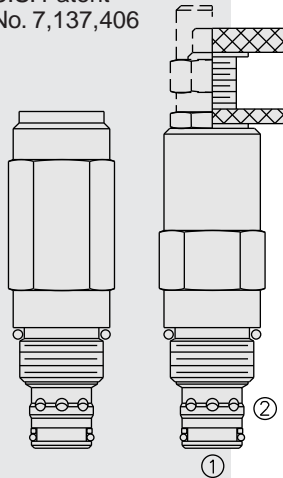

DESCRIPTION

A screw-in, cartridge-style, pilot-operated (two-stage), spool-type hydraulic relief valve, intended for use as a pressure limiting device in demanding hydraulic circuits which require fast response and low hysteresis.

OPERATION

The **RV50-26** blocks flow from ① to ② until sufficient pressure is present at ① to force the piloting relief off its seat, allowing the main (second stage) spool to shift, opening ① to ②.

The cartridge offers smooth transition in response to load changes in demanding hydraulic circuits.

NOTE: The RV50-26 may not be used in cross-over relief applications (back pressure on ②).

FEATURES

- Adjustments cannot be backed out of the valve.
- Adjustments prohibit springs from going solid.
- Hardened spool and cage for long life.
- Fast, smooth response to pressure surges.
- Industry common cavity.

RATINGS

Operating Pressure: 345 bar (5000 psi)

Flow: The Performance Chart illustrates flow handling capacity at maximum setting. Pressure rise will vary with setting due to flow forces. Consult factory for specific flow characteristic values.

Internal Leakage: 115 cc/minute (7 cu. in./minute) max. to 85% of nominal setting

Crack Pressure Defined: bar (psi) evident at 7.6 lpm (2.0 gpm) attained

Reseat Pressure: Nominal 90% of crack pressure

Standard Spring Ranges: 27.6 to 345 bar (400 to 5000 psi)

Temperature: -40 to 120°C

Filtration: See page 9.010.1

Fluids: Mineral-based or synthetics with lubricating properties at viscosities of 7.4 to 420 cSt (50 to 2000 sus); See Temperature and Oil Viscosity, page 9.060.1

Installation: No restrictions; See page 9.020.1

Cavity: VC10-2; See page 9.110.1

Cavity Tool: CT10-2XX; See page 8.600.1

Seal Kit: SK10-2P-B; See page 8.650.1

SYMBOLS

USAS/ISO:

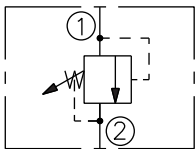

PERFORMANCE (Cartridge Only)

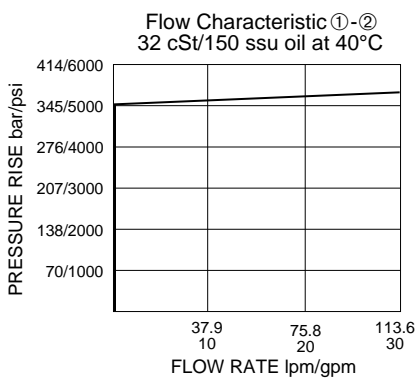

DIMENSIONS

U.S. Patent No. 7,137,406

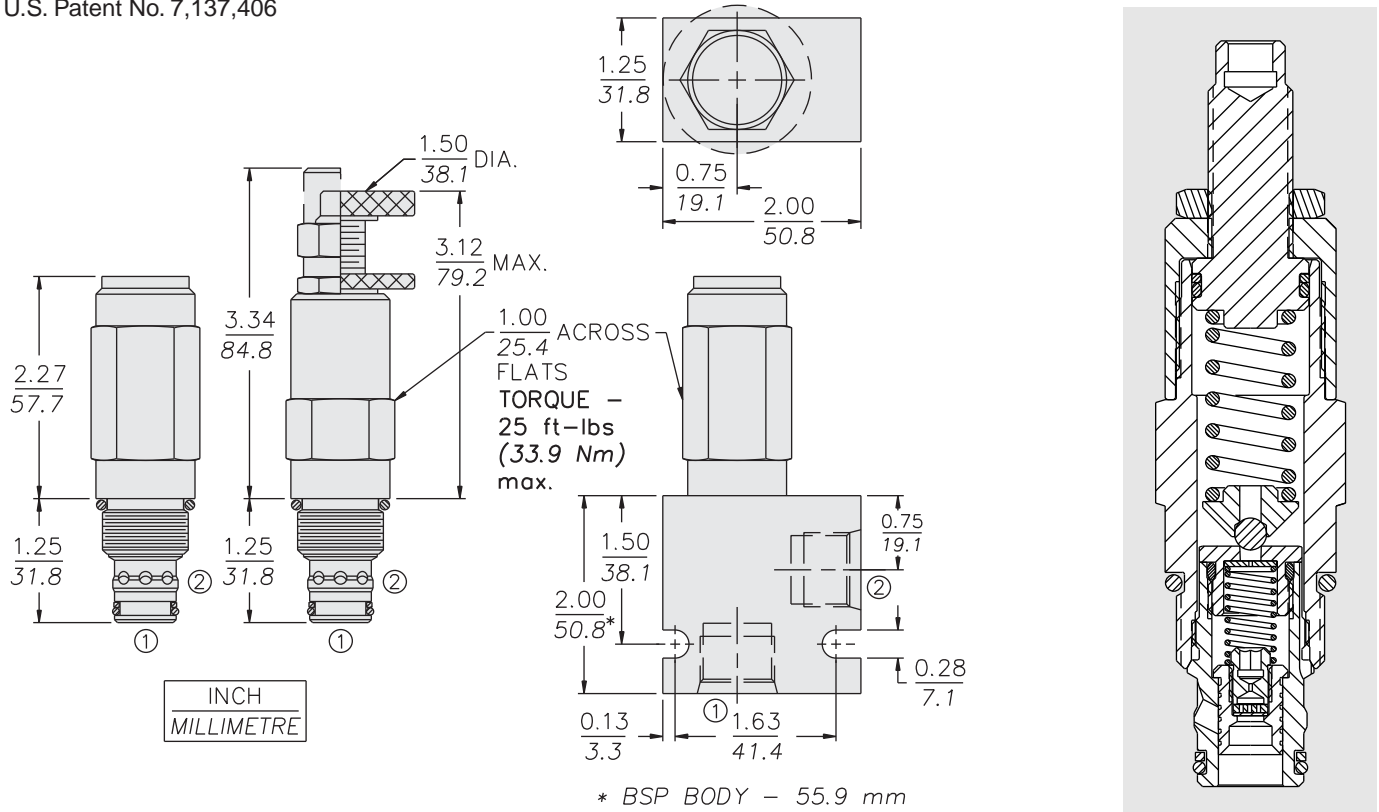

MATERIALS

Cartridge: Weight: 0.25 kg. (0.55 lbs.)
 Steel with hardened work surfaces.
 Zinc-plated exposed surfaces.
 Poly-urethane seals with
 Fluorocarbon back-ups for
 pressures over 240 bar (3500 psi).
 Anodized aluminum knobs.

Ported Body: Weight: 0.54 kg.
 (1.2 lbs.) Ductile Iron (code "D")
 standard, consult factory for
 weight, dimensions may differ.
 Rated to 345 bar (5000 psi).
 See page 8.010.1

TO ORDER

RV50-26

- Adjustment Option**
- 1/4 in. Hex Allen Head **A**
- 1-1/2 in. Dia. Alum. Knob **B**
- Option A w/ Cover Cap **C**
- Factory Preset Non-Adj. **F**
- Factory Preset Hidden Adjustment **H**
- Option C with Lockwire Holes **L**
- Porting**
- Cartridge Only **0**
- SAE 6 **6TD**
- SAE 8 **8TD**
- 3/8 in. BSP* **3BD**
- 1/2 in. BSP* **4BD**

- Seals**
- Pressure on P Only:**
- P** Polyurethane (Std.)

- Setting in bar[†]**
- (Blank) for Adjustable, or Specify, for example:
- M83** 83 bar
- M200** 200 bar
- Setting in psi[†]**
- (Blank) for Adjustable, or Specify, for example:
- 12.0** 1200 psi
- 29.0** 2900 psi

- Spring Range**
- 50** 27.6 to 345 bar (400 to 5000 psi)

[†]Adjustable valves will be preset to approx. 50% of spring max. potential.

*BSP Body; U.K. Mfr. Only