

CRV10-22 Cross-Over Relief, Differential Area Poppet

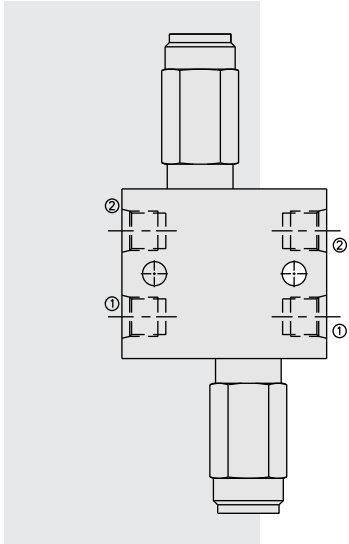

DESCRIPTION

The **CRV10-22** cross-port relief uses two RV10-22 cartridges in an in-line plumbed housing. It is typically used to protect a hydraulic cylinder or motor from load-induced pressure surges. The cartridges used are screw-in, differential area, poppet-type valves, intended for use in lower flow circuits requiring low internal leakage.

OPERATION

The CRV10-22 manifold allows flow to pass through the separated ① to ② passages at low pressure loss. If pressure in either passage exceeds the valve setting, flow will cross over to the opposite passage.

Note: Back-pressure at the outlet port of the relief cartridges will increase the nominal setting of the valve on a 1:1 basis (i.e. 6.9 bar/100 psi back-pressure increases the nominal setting by 6.9 bar/100 psi).

See catalog page 6.050.1 for cartridge specifications.

FEATURES

- Adjustments cannot be backed out of the valve.
- Adjustments prohibit springs from going solid.
- Hardened poppet and cage for long life.
- Optional spring ranges to 240 bar (3500 psi).
- Smooth response to pressure surges.
- Industry common cavity.

SYMBOLS

USAS/ISO:

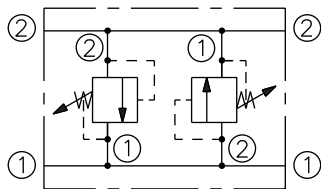

PERFORMANCE (Cartridge Only)

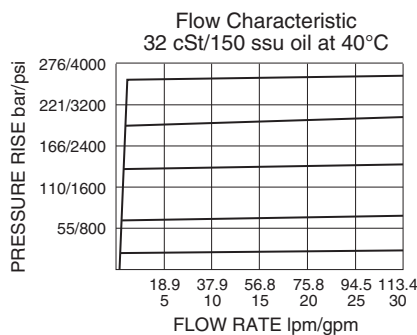

RATINGS

Operating Pressure: 240 bar (3500 psi)

Flow: The Performance Chart illustrates flow handling capacity at maximum setting for each spring range option. Pressure rise will vary with spring (range) and with setting within range due to flow forces. Consult factory for specific flow characteristic values.

Pressure Rise: 0.34 bar/l (5 psi/g)

Internal Leakage: 0.25 cc/minute (5 drops/minute) max. to 85% of nominal setting

Crack (Set) Pressure Defined: bar (psi) evident at 0.95 lpm (0.25 gpm) attained

Standard Spring Ranges:

- 6.9 to 41.4 bar (100 to 600 psi) at 90% crack vs. reseal accuracy;
- 10.3 to 89.7 bar (150 to 1300 psi) at 90% accuracy;
- 34.5 to 172.4 bar (500 to 2500 psi) at 90% accuracy;
- 34.5 to 241.4 bar (500 to 3500 psi) at 90% accuracy

Temperature: -40 to 120°C

Filtration: See page 9.010.1

Fluids: Mineral-based or synthetics with lubricating properties at viscosities of 7.4 to 420 cSt (50 to 2000 sus); See Temperature and Oil Viscosity, page 9.060.1

Installation: No restrictions; See page 9.020.1

Seal Kit: SK10-2X-M (for cross-over relief application) (2 required)

Body Part Number: 7070170

DIMENSIONS

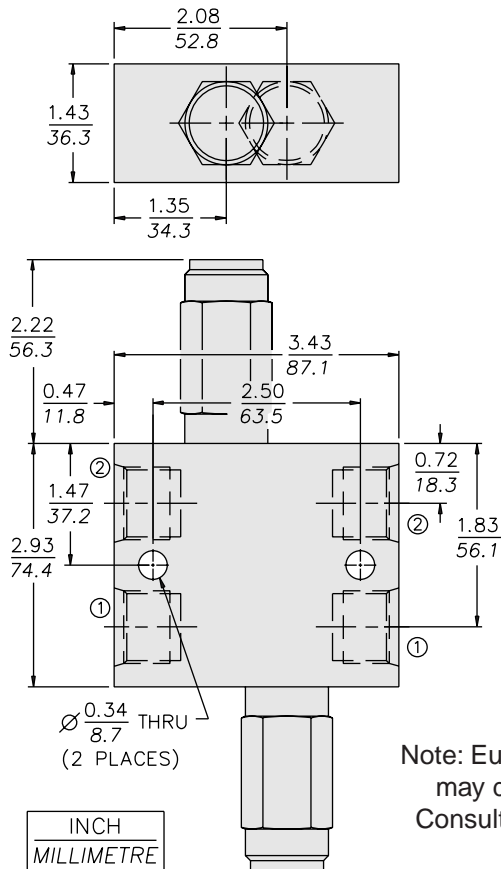

Note: European manufactured version may differ in design/dimensions. Consult HydraForce Hydraulics Ltd.

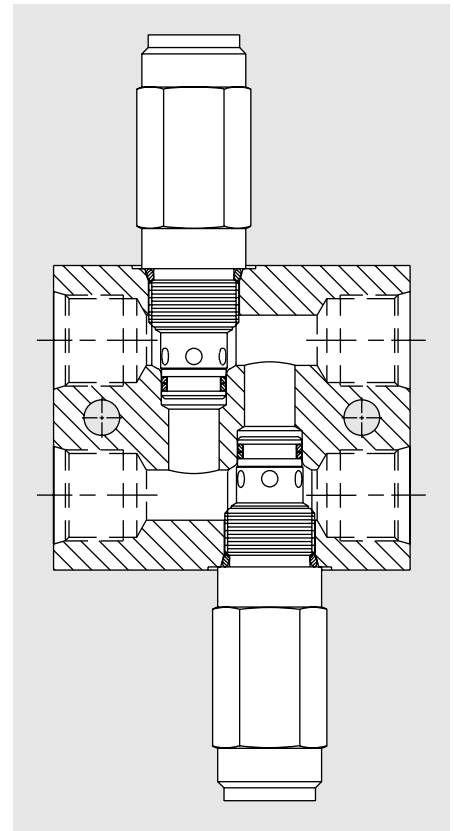

MATERIALS

Cartridges: (2 Required) Weight: 0.23 kg. (0.50 lbs.) Steel with hardened work surfaces. Zinc-plated exposed surfaces. Buna N O-rings and Fluorocarbon back-ups standard. Anodized aluminum knob.

Standard Ported Body: Weight: 0.50 kg. (1.10 lbs.) Anodized high-strength 6061 T6 aluminum alloy, rated to 207 bar (3000 psi).

TO ORDER

