

ER12-S30 Pressure Reducing Spool Logic Element

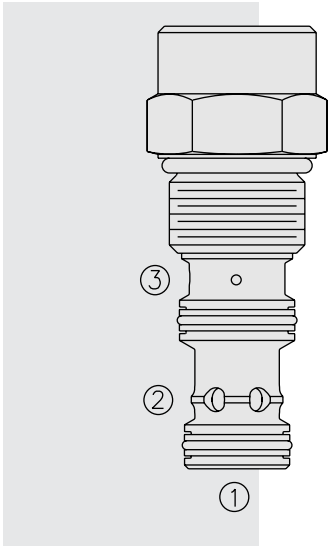

DESCRIPTION

A screw-in, cartridge-style, spring biased, pressure reducing logic element.

OPERATION

In its steady state, the **ER12-S30** allows flow from ② to ① with the spring chamber constantly drained at ③. On attainment of a pre-determined pressure at ①, set by a (remote) pilot relief valve connected to port ③, the spool shifts to restrict input flow at ②, thereby regulating pressure at ①.

FEATURES

- Adjustments cannot be backed out of the valve.
- Adjustments prohibit springs from going solid.
- Optional spring ranges to 207 bar (3000 psi).
- Hardened spool and cage for long life.
- Industry common cavity.

RATINGS

Operating Pressure: 350 bar (5000 psi); Polyurethane seals are recommended for operation up to 5000 psi; Aluminum bodies for this product are rated to 3000 psi

Proof Pressure: 390 bar (5700 psi)

Flow: See Performance Chart

Maximum Pilot Flow: 9.5 lpm (2.5 gpm)

Bias Spring: 8.3 bar (120 psi)

Temperature: -40 to 120°C with standard Buna seals

Filtration: See page 9.010.1

Fluids: Mineral-based or synthetics with lubricating properties at viscosities of 7.4 to 420 cSt (50 to 2000 sus); See Temperature and Oil Viscosity, page 9.060.1

Installation: No restrictions; See page 9.020.1

Cavity: VC12-S3; See page 9.112.1

Cavity Tool: CT12-S3XX; See page 8.600.1

Seal Kit: SK12-3X-BM; See page 8.650.1

SYMBOLS

USASI/ISO:

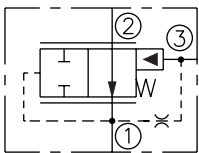

PERFORMANCE (Cartridge Only)

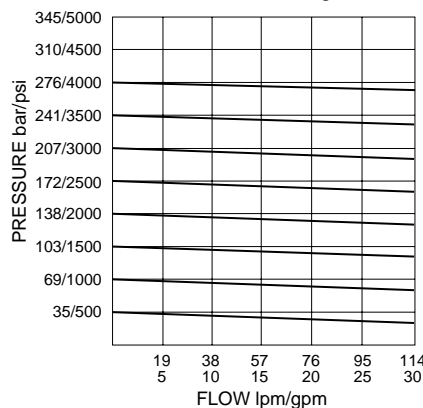
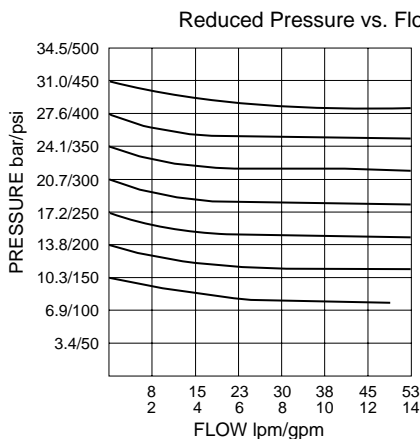
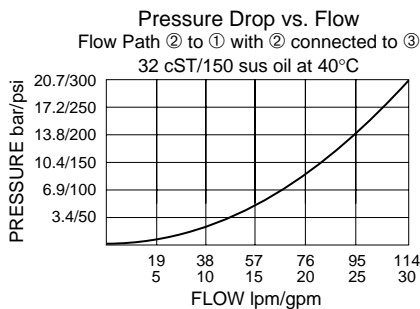

DIMENSIONS

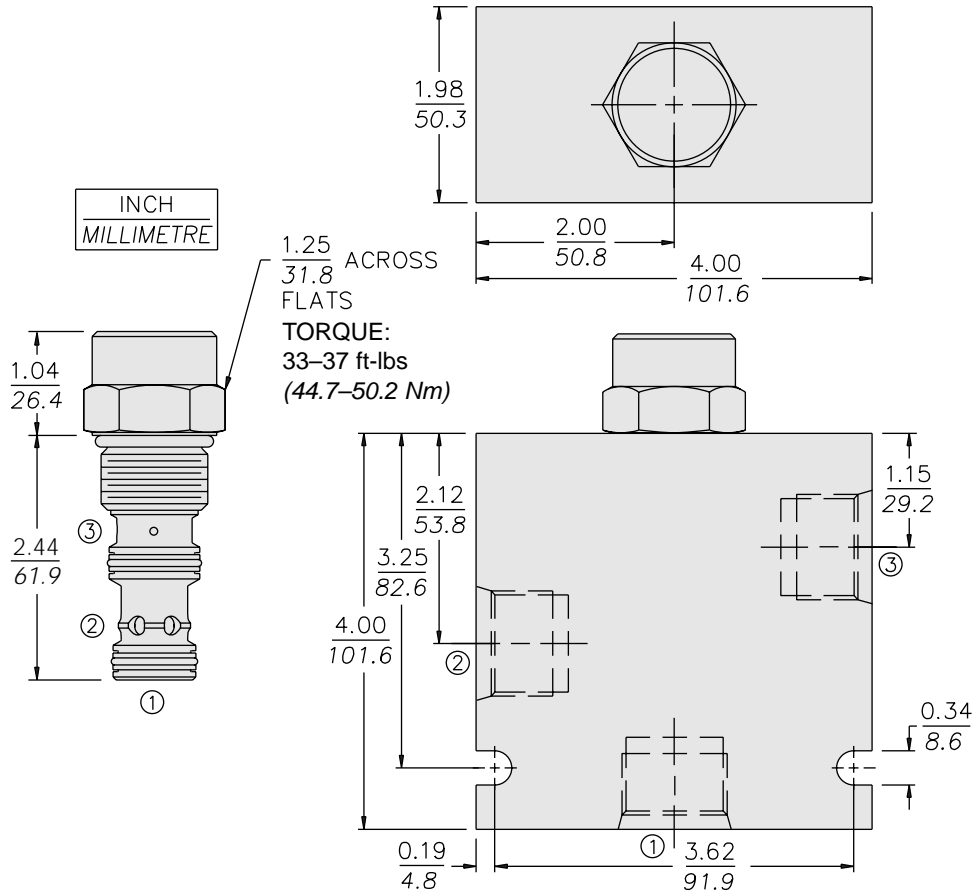

MATERIALS

Cartridge: Weight: 0.29 kg. (0.63 lbs.)
 Steel with hardened work surfaces.
 Zinc-plated exposed surfaces.
 Buna N O-rings and polyester elastomer back-ups standard.

Standard Ported Body: Weight: 1.13 kg. (2.5 lbs.) Anodized high-strength 6061 T6 aluminum alloy, rated to 207 bar (3000 psi). Ductile iron bodies available; dimensions may differ. See page 8.012.1.

TO ORDER

ER12-S30 -

Porting	
Cartridge Only	0
SAE 8	8T
SAE 10	10T
SAE 12	12T
1/2 in. BSP*	4B
3/4 in. BSP*	6B
*BSP Body; U.K. Mfr. Only	
Seals	
Buna N (Std.)	N
Polyurethane	P
Fluorocarbon	V

Note: Polyurethane seals are recommended for operation over 241 bar (3500 psi)