

# PS10-35 Sequence, External Pilot, Internal Drain

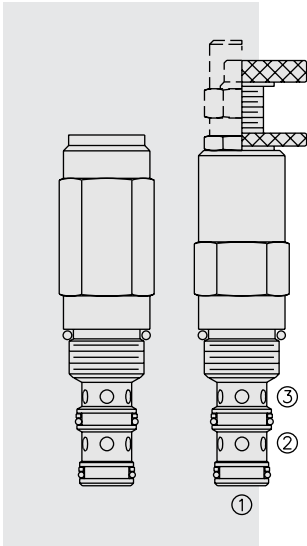

## DESCRIPTION

A screw-in, cartridge-style, direct-acting, spool-type, hydraulic sequence valve with external pilot and internal spring chamber drain.

## OPERATION

In its steady state, the **PS10-35** allows flow from ② to ③.

On attainment of a pre-determined pressure at ①, the cartridge shifts to close ② to ③. Since the spring chamber is vented at ③, back pressure at ③ will directly (1:1) affect the valve's setting.

## FEATURES

- Adjustments cannot be backed out of the valve.
- Adjustments prohibit springs from going solid.
- Hardened spool and cage for long life.
- Compact size.

## RATINGS

**Operating Pressure:** 138 bar (2000 psi)

**Flow:** See Performance Chart

**Internal Leakage:** 82 cc/minute (5 cu. in./minute) max. at full close

**Standard Spring Ranges:** 6.9 to 138 bar (100 to 2000 psi)

**Temperature:** -40 to 120°C with standard Buna seals

**Filtration:** See page 9.010.1

**Fluids:** Mineral-based or synthetics with lubricating properties at viscosities of 7.4 to 420 cSt (50 to 2000 sus); See Temperature and Oil Viscosity, page 9.060.1

**Installation:** No restrictions; See page 9.020.1

**Cavity:** VC10-3; See page 9.110.1

**Cavity Tool:** CT10-3XX; See page 8.600.1

**Seal Kit:** SK10-3X-BM; See page 8.650.1

## SYMBOLS

### USASI:

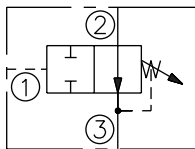

### ISO:

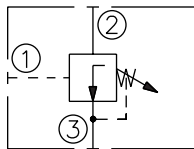

## PERFORMANCE (Cartridge Only)

