

KS10-31 Kick-Down, Sequence, Internal Pilot

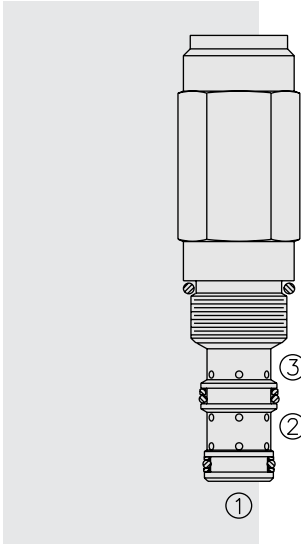

DESCRIPTION

A screw-in, cartridge-style, direct-acting, spool-type, hydraulic sequence valve with internal pilot and spring chamber drain, designed to direct flow to a secondary circuit once a pre-determined pressure level is attained in the primary circuit. The valve will remain shifted until the pressure in the secondary circuit falls below a lower pressure setting determined by a second spring.

OPERATION

In its steady state, the **KS10-31** blocks flow at ③, while allowing flow to pass from ① to ②.

On attainment of a pre-determined pressure at ①, the cartridge shifts to open ② to ③.

FEATURES

- Adjustments cannot be backed out of the valve.
- Adjustments prohibit springs from going solid.
- Optional spring ranges to 207 bar (3000 psi).
- Hardened spool and cage for long life.
- Industry common cavity.

RATINGS

Operating Pressure: 207 bar (3000 psi)

Flow: See Performance Chart

Internal Leakage ① to ②: 115 cc/minute (7 cu. in./minute) max. to 85% of nominal setting

Crack Pressure Defined: bar (psi) evident at ① when 0.95 lpm (0.25 gpm) attained ② to ③

Standard Spring Ranges (Primary Spring):

27.6 to 207 bar (400 to 3000 psi)

Standard Spring Setting (Optional Secondary Spring):

7 bar (100 psi); 10 bar (150 psi); 14 bar (200 psi); 17 bar (250 psi)

Temperature: -40 to 120°C with standard Buna seals

Filtration: See page 9.010.1

Fluids: Mineral-based or synthetics with lubricating properties at viscosities of

7.4 to 420 cSt (50 to 2000 sus); See Temperature and Oil Viscosity, page 9.060.1

Installation: No restrictions; See page 9.020.1

Cavity: VC10-3; See page 9.110.1

Cavity Tool: CT10-3XX; See page 8.600.1

Seal Kit: SK10-3X-BB; See page 8.650.1

SYMBOLS

USASI/ISO:

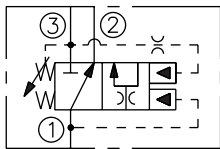

PERFORMANCE (Cartridge Only)

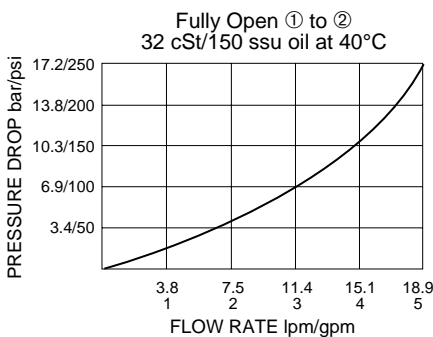

DIMENSIONS

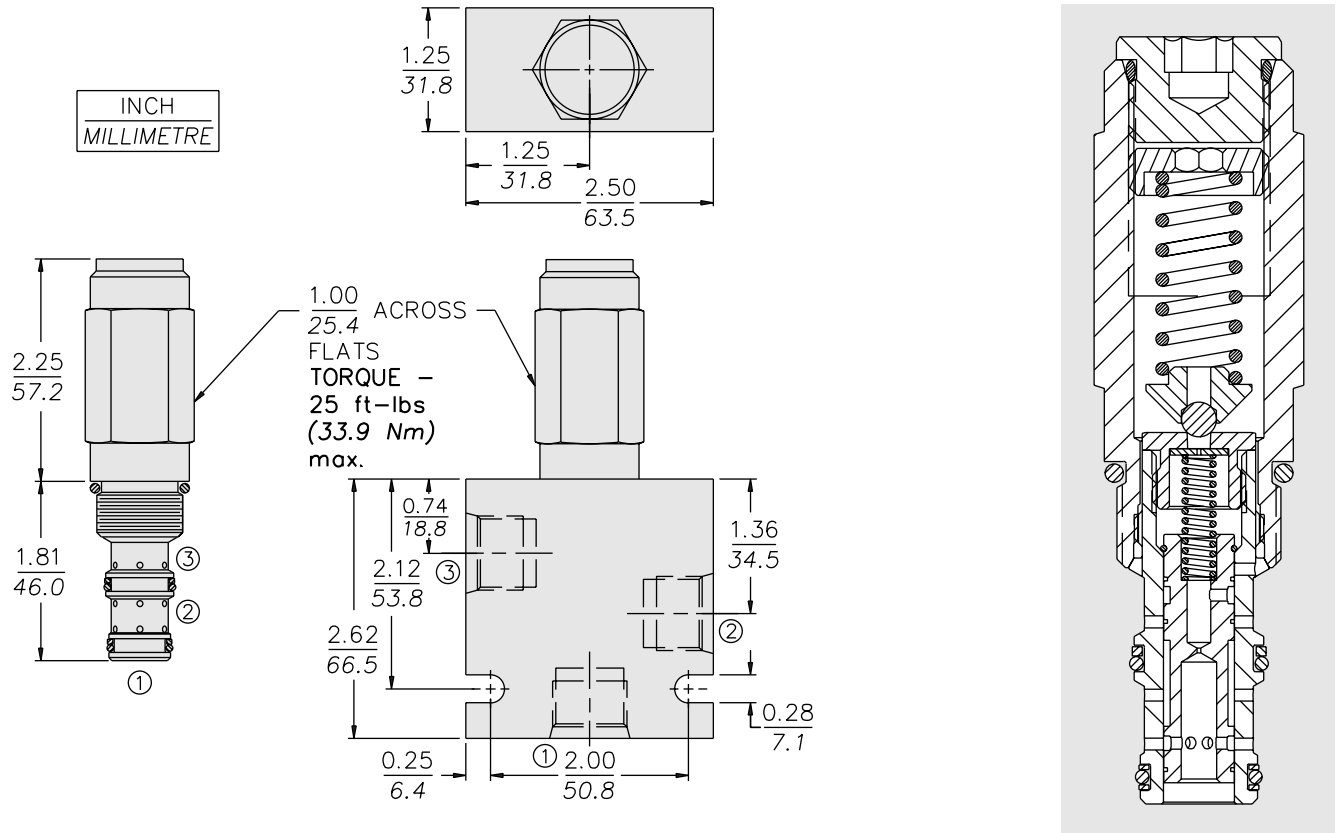

MATERIALS

Cartridge: Weight: 0.27 kg. (0.60 lbs.)
Steel with hardened work surfaces.
Zinc-plated exposed surfaces.
Buna N O-rings and polyester elastomer back-ups standard.
Anodized aluminum knobs and caps.

Standard Ported Body: Weight: 0.36 kg. (0.80 lbs.)
Anodized high-strength 6061 T6 aluminum alloy, rated to 207 bar (3000 psi). Ductile iron bodies available; dimensions may differ. See page 8.010.1

TO ORDER

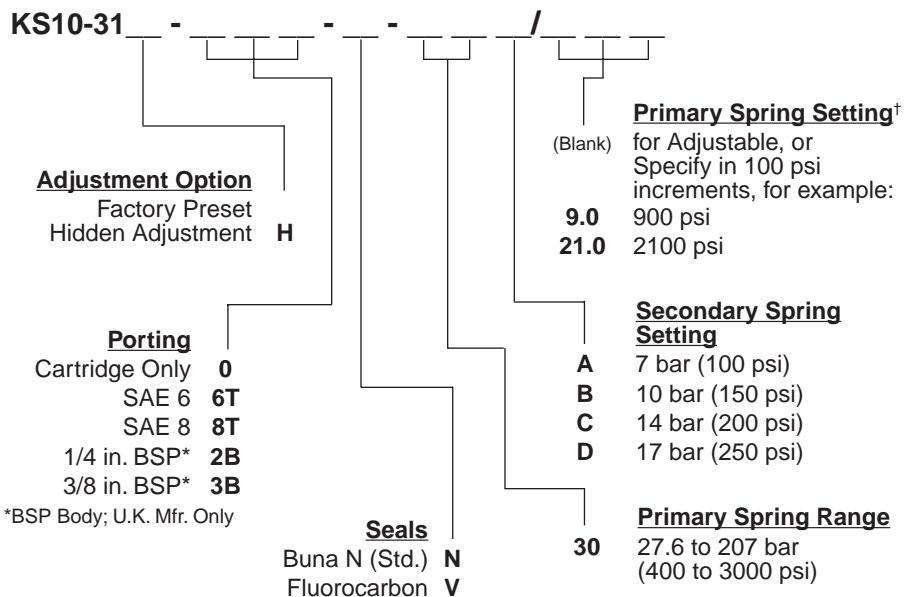

[†]Adjustable valves will be preset to approx. 50% of spring max. potential.