

ELECTRO-PROPORTIONAL VALVES—FLOW CONTROLS

PV16-23 Proportional Flow Control Cartridge,

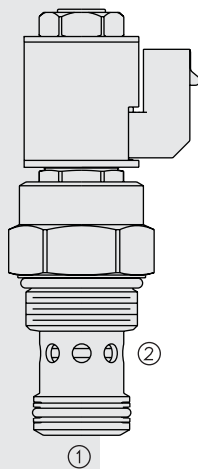

SYMBOL

USASI/ISO:

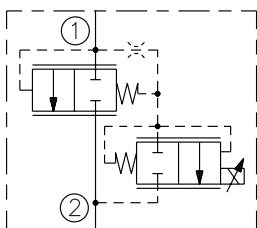

DESCRIPTION

A solenoid-operated, two-way, normally closed, electro-proportional, hydraulic cartridge valve intended for use with an external pressure compensator or load-sensing-style pump control.

OPERATION

When de-energized, the **PV16-23** blocks flow from ① to ②. With increasing current applied to the solenoid, output flow from ① to ② will increase proportionally.

The PV16-23 is intended for use with an operating differential across the valve of 7 bar to 11 bar (100 psi to 160 psi). The set value of the external pressure compensator or pump control must provide for both the valve operating differential, as well as for system losses between the compensator and the PV16-23 at the maximum required flow.

Operation of Manual Override: To Engage: Turn clockwise approximately 1 turn to reach start point. Continue another approximately 5 turns to full shift. To Disengage: Turn counterclockwise approximately 6 turns to positive stop.

FEATURES

- Excellent linearity and hysteresis characteristics.
- Hardened spool and cage for long life.
- Optional coil voltages and terminations.
- Efficient wet armature construction.

RATINGS

Maximum Operating Pressure: 241 bar (3500 psi)

Maximum Flow Rate: 95 to 170 lpm (25 to 45 gpm); see performance graphs.

Maximum Internal Leakage: 0.38 lpm (0.10 gpm) at port ② with 13.8 bar (200 psi) at port ① with no current applied.

Electrical: EHPR08 Coil, 2 standard voltage ratings

Coil Voltage	Resistance at 20°C	Threshold Current	Max. Control Current
12 VDC	5.4 ohms	400 ± 100 mA	1400 ± 100 mA
24 VDC	21.7 ohms	200 ± 50 mA	700 ± 50 mA

Filtration: See page 9.010.1

Fluids: Mineral-based or synthetics with lubricating properties at viscosities of 7.4 to 420 cSt (50 to 2000 sus); See Temperature and Oil Viscosity, page 9.060.1

Installation: No restrictions; See page 9.020.1.

Cavity: VC16-2; See page 9.116.1; **Cavity Tool:** CT16-2XX; See page 8.600.1

Seal Kit: SK16-2X-M; See page 8.650.1 for seal kit options

and appropriate seals based on application temperature range.

PERFORMANCE (Cartridge Only)

Pressure Drop vs. Flow ① to ②
at Maximum Control Current
12V EHPR08 Coil, 110 Hz PWM
138 bar/2000 psi load at ②
32 cSt/150 sus oil at 40°C

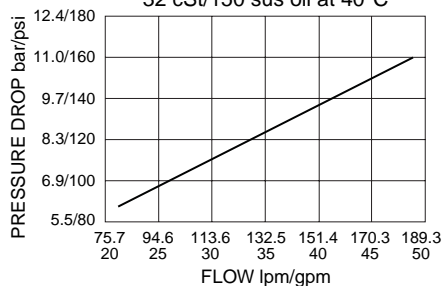

Flow vs. Current at 207 bar/3000 psi
Compensating Inlet at 10.3 bar/150 psi
12V EHPR08 Coil, 110 Hz PWM
32 cSt/150 sus oil at 40°C

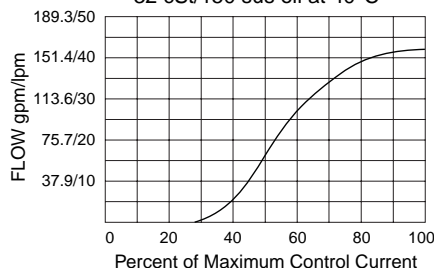

Recommended Electronic Controllers:
See page 2.001.1 or our Electronics catalog.

Normally Closed

PV16-23

DIMENSIONS

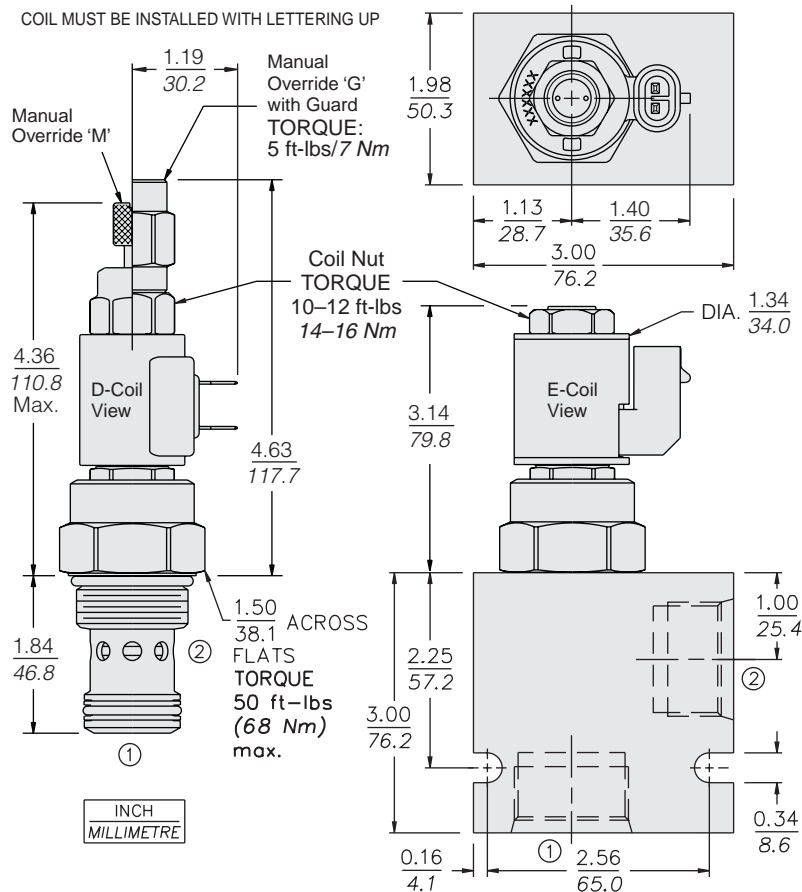

MATERIALS

Cartridge: Weight: 0.46 kg. (1.02 lbs.) Steel with hardened work surfaces. Zinc-plated exposed surfaces. Buna N O-rings and polyester elastomer back-up standard.

Standard Ported Body: Weight: 0.57 kg. (1.25 lbs.) Anodized high-strength 6061 T6 aluminum alloy, rated to 207 bar (3000 psi). Ductile iron bodies available; dimensions may differ. See page 8.016.1

EHP08 D-Coil: Weight: 0.10 kg. (0.22 lbs.) Unitized thermoplastic encapsulated, Class H high temperature magnetwire. See page 3.200.1

EHP08 E-Coil: Weight: 0.14 kg. (0.3 lbs.) Fully encapsulated with rugged external metal shell. Rated up to IP69K with integral connectors. See page 3.400.1

TO ORDER

PV16-23

Option
None (Blank)
Manual Override **M**
Manual Override with Guard **G**
For Manual Override info. see page 1.001.1

Porting
Cartridge Only **0**
SAE 12 **12T**
SAE 16 **16T**
3/4 in. BSP* **6B**
1 in. BSP* **8B**
*BSP Body; U.K. Mfr. Only

Coil Voltage
0 Less Coil**
12 12 VDC
24 24 VDC
** Includes D-Coil Nut

Seals
N Buna N (Std.)
V Fluorocarbon

Termination (VDC) D-Coil

DS Dual Spades
DG DIN 43650
DL Leadwires (2)
DL/W Leads w/Weatherpak® Connectors

Termination (VDC) E-Coil

ER Deutsch DT04-2P (IP69K Rated)
EY Metri-Pack® 150 (IP69K Rated)

Coils with internal diode are available. Consult factory.