

# ELECTRO-PROPORTIONAL VALVES—FLOW CONTROLS

## PV70-30 Proportional Flow Control Cartridge,

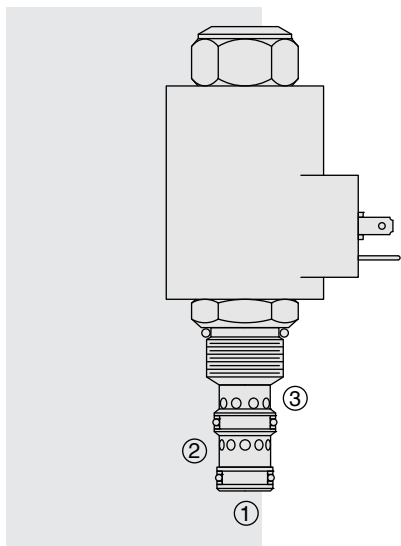

### DESCRIPTION

A solenoid-operated, electrically-variable, three-port, pressure-compensated, spool-type, normally closed when de-energized, proportional flow control valve. It can be used as a priority-type flow regulator with pressure-compensated, regulated and bypass flow. It can also be used as a restrictive-type 2-way, pressure-compensated flow regulator when the bypass line (port 2) is blocked.

### OPERATION

The PV70-30 will regulate flow out of port 3 regardless of system working pressure. With an increasing current applied to the solenoid, the PV70-30 will increase output flow.

**Note:** When used as a bypass flow control in applications where the priority flow port will be blocked by external valving, bypass pressure drop will increase unless a small amount of leakage is provided for the priority port. Consult factory.

#### Operation of Manual Override:

To Engage: Turn clockwise approximately 1 turn to reach start point. Continue another approximately 5 turns to full shift.

To Disengage: Turn counterclockwise approximately 6 turns to positive stop.

### FEATURES

- Excellent linearity and hysteresis.
- Hardened spool and cage for long life.
- Optional coil voltages and terminations.
- Efficient wet armature construction.
- Cartridges voltage interchangeable.
- Unitized, molded coil design.
- Coil waterproofing standard.
- Manual override option.

### SYMBOLS

#### USASI/ISO:

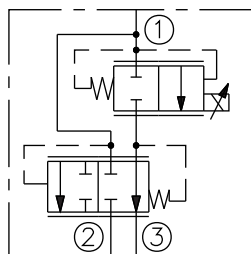

### PERFORMANCE

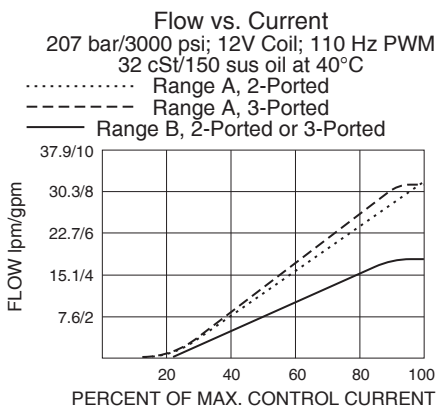

Performance info. continued on following page.

### RATINGS

**Operating Pressure:** Inlet: 240 bar (3500 psi); Ports 2 and 3: 207 bar (3000 psi)

**Regulated Flow Rate:** Bypass Blocked, Range A: 26 lpm (7 gpm)  
Bypass Blocked, Range B: 17 lpm (4.5 gpm)  
Bypass Open, Range A: 30 lpm (8 gpm)  
Bypass Open, Range B: 17 lpm (4.5 gpm)

**Maximum Input Flow:** Bypass Open, Range A: 50 lpm (13 gpm)  
Bypass Open, Range B: 26 lpm (7 gpm)

**Internal Leakage:** 197 cc/min. (12 cu. in./min.) fully closed at 207 bar (3000 psi)

**Electrical:** 2 standard voltage ratings

Coil Voltage	Threshold Current	Max. Control Current
12 VDC	250 ± 100 mA	1250 ± 150 mA
24 VDC	125 ± 50 mA	600 ± 75 mA

**Filtration:** See page 9.010.1

**Fluids:** Mineral-based or synthetics with lubricating properties at viscosities of 7.4 to 420 cSt (50 to 2000 sus); See Temperature and Oil Viscosity, page 9.060.1

**Installation:** No restrictions; See page 9.020.1.

**Cavity:** VC10-3; See page 9.110.1

**Cavity Tool:** CT10-3X-XX; See page 8.600.1

**Seal Kit:** SK10-3X-MM; See page 8.650.1 for seal kit options and appropriate seals based on application temperature range.

#### Recommended Electronic Controllers:

See page 2.001.1 or our Electronics catalog.

# Normally Closed

# PV70-30

## PERFORMANCE (Continued)

Regulated Flow vs. Pressure Drop  
2-Ported; Flow Range A  
240 bar/3500 psi Inlet  
12V Coil; 110 Hz PWM  
32 cSt/150 sus oil at 40°C

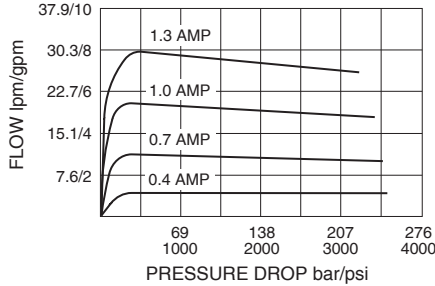

Regulated Flow vs. Pressure Drop  
2-Ported; Flow Range B  
240 bar/3500 psi Inlet  
12V Coil; 110 Hz PWM  
32 cSt/150 sus oil at 40°C

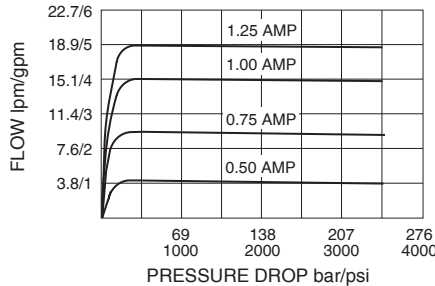

## DIMENSIONS

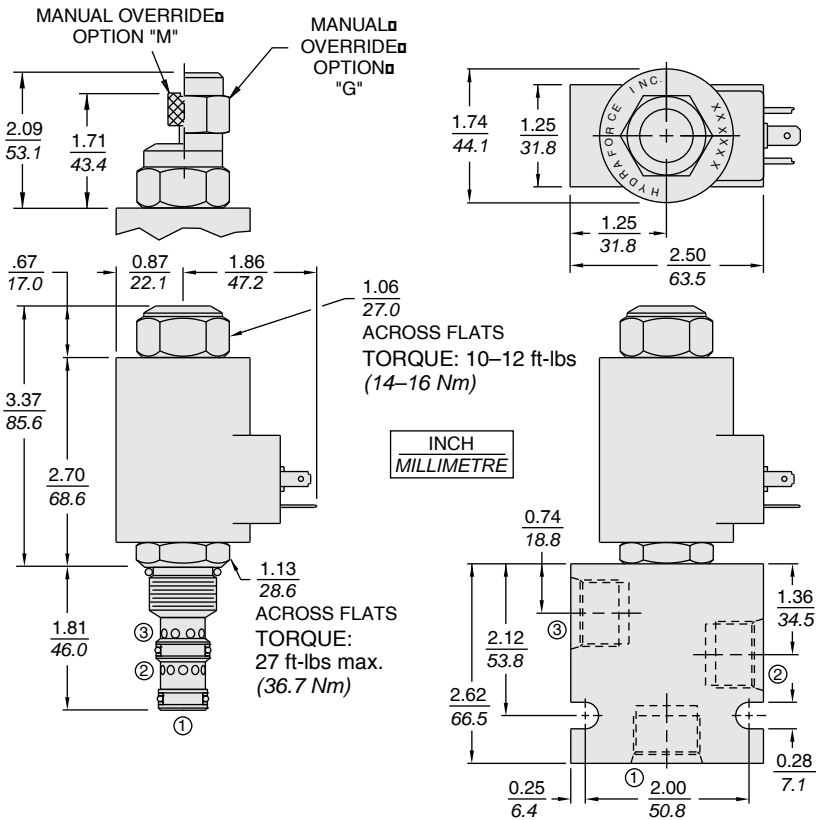

## MATERIALS

**Cartridge:** Weight: 0.19 kg. (0.42 lbs.)  
Steel with hardened work surfaces.  
Zinc-plated exposed surfaces. Buna N O-rings and polyester elastomer back-ups standard.

**Standard Ported Body:** Weight: 0.36 kg. (0.80 lbs.)  
Anodized high-strength 6061 T6 aluminum alloy, rated to 207 bar (3000 psi). Ductile iron bodies available; dimensions may differ. See page 8.010.1

**70-Size "D" Coil:** Weight: 0.32 kg. (0.7 lbs.)  
Unitized thermoplastic encapsulated, Class H high temperature magnet-wire. See page 3.200.7.

**70-Size "E" Coil:** Weight: 0.41 kg. (0.9 lbs.)  
Fully encapsulated with rugged external metal shell. IP69K rated. See page 3.400.13.

## TO ORDER

