

ELECTRO-PROPORTIONAL VALVES—FLOW CONTROLS

PV76-30A Proportional Flow Control Cartridge,

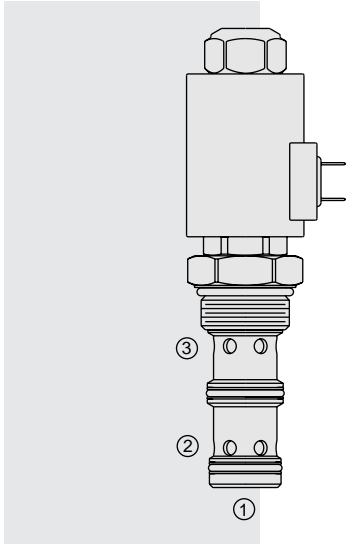

DESCRIPTION

A solenoid-operated, electrically-variable, three-port, pressure-compensated, spool-type, normally closed when de-energized, proportional flow control valve. It can be used as a priority-type flow regulator with pressure-compensated, regulated and bypass flow. It can also be used as a restrictive-type 2-way, pressure-compensated flow regulator when the bypass line (port ②) is blocked.

OPERATION

The **PV76-30A** will regulate flow out of port ③ regardless of system working pressure. With increasing current applied to the solenoid, output flow will increase.

Note: When used as a bypass flow control in applications where the priority flow port will be blocked by external valving, bypass pressure drop will increase unless a small amount of leakage is provided for the priority port. Consult factory.

Operation of Manual Override: To Engage: Turn clockwise approximately 1 turn to reach start point. Continue another approximately 5 turns to full shift. To Disengage: Turn counterclockwise approximately 6 turns to positive stop.

FEATURES

- Excellent linearity and hysteresis characteristics.
- Hardened spool and cage for long life.
- Optional coil voltages and terminations.
- Efficient wet armature construction.

SYMBOLS

USASI/ISO:

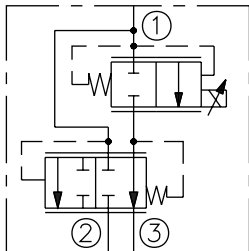

RATINGS

Operating Pressure: Inlet: 240 bar (3500 psi); Ports ② and ③: 207 bar (3000 psi)

Regulated Flow Rate: Range A: 3-Ported: 94.6 lpm (25.0 gpm)
Range A: 2-Ported: 85.2 lpm (22.5 gpm)

Nominal Input Flow: Bypass Open, 3-Ported: 121 lpm (32.0 gpm)

Maximum Input Flow: Bypass Open, 3-Ported: 151.4 lpm (40.0 gpm)

Internal Leakage: 0.38 lpm (0.10 gpm) at zero current

Electrical: 2 standard voltage ratings

Coil Voltage	Threshold Current	Max. Control Current
12 VDC	300 ± 100 mA	1600 ± 100 mA
24 VDC	150 ± 50 mA	800 ± 50 mA

Filtration: See page 9.010.1

Fluids: Mineral-based or synthetics with lubricating properties at viscosities of 7.4 to 420 cSt (50 to 2000 sus); See Temperature and Oil Viscosity, page 9.060.1

Installation: No restrictions; See page 9.020.1.

Cavity: VC16-3; See page 9.116.1; **Cavity Tool:** CT16-3X-XX; See page 8.600.1

Seal Kit: SK16-3X-MM; See page 8.650.1 for seal kit options and appropriate seals based on application temperature range.

PERFORMANCE

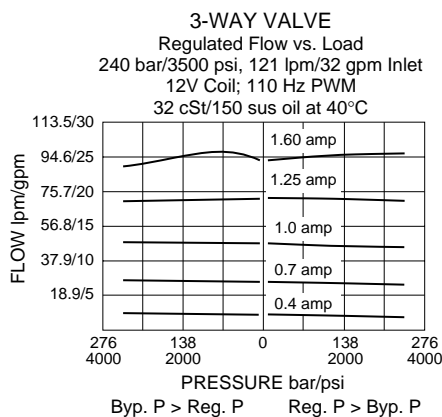
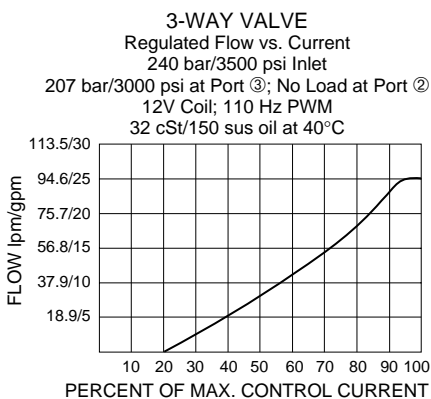

Recommended Electronic Controllers:
See page 2.001.1 or our Electronics catalog.

Normally Closed

PV76-30A

PERFORMANCE (continued)

2-WAY VALVE
Regulated Flow vs. Current
240 bar/3500 psi Inlet
207 bar/3000 psi at Port ③
12V Coil; 110 Hz PWM
32 cSt/150 sus oil at 40°C

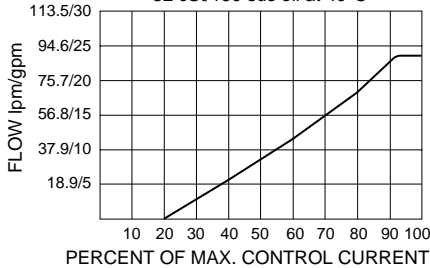

2-WAY VALVE
Regulated Flow vs. Pressure Drop
240 bar/3500 psi Inlet
12V Coil; 110 Hz PWM
32 cSt/150 sus oil at 40°C

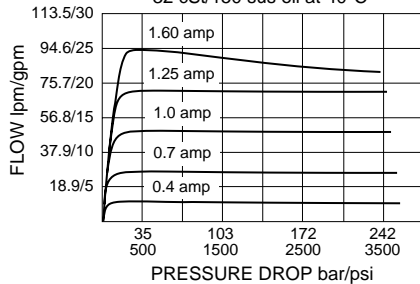

DIMENSIONS

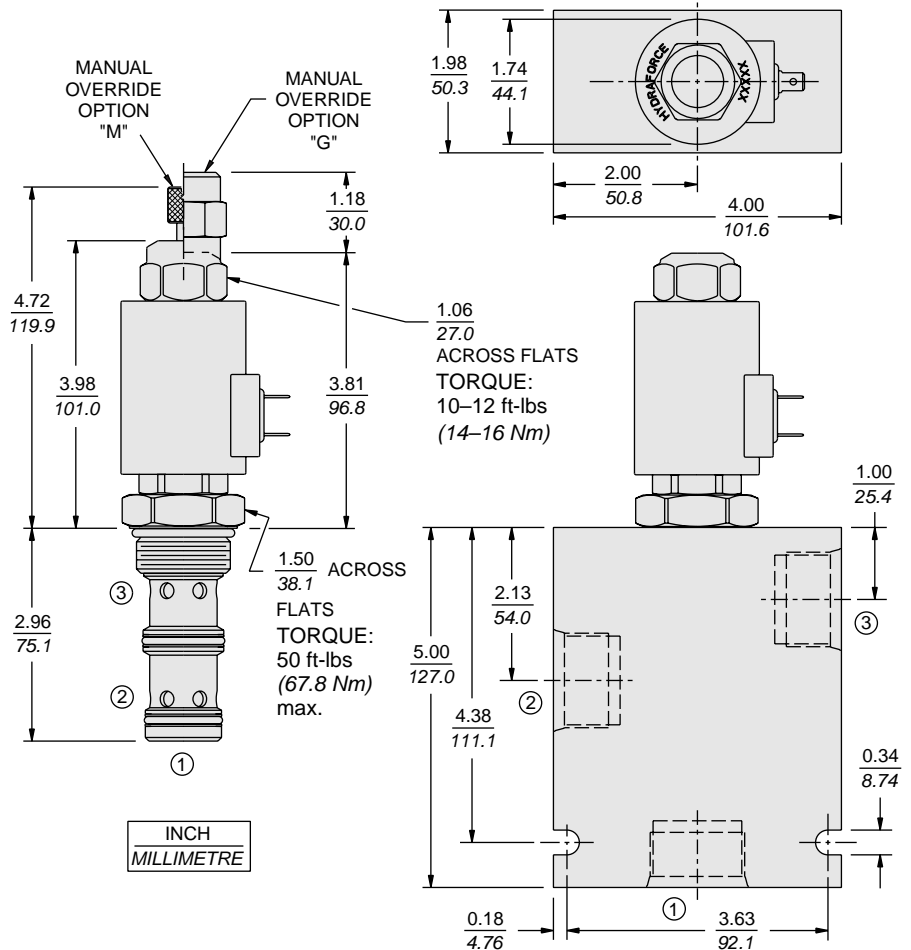

MATERIALS

Cartridge: Weight: 0.54 kg. (1.19 lbs.)
Steel with hardened work surfaces.
Zinc-plated exposed surfaces.
Buna N O-rings and polyester elastomer back-ups standard.

Standard Ported Body: Weight: 1.6 kg. (3.35 lbs.) Anodized high-strength 6061 T6 aluminum alloy, rated to 207 bar (3000 psi). Ductile iron bodies available; dimensions may differ. See page 8.016.1

70-Size "D" Coil: Weight: 0.32 kg. (0.7 lbs.) Unitized thermoplastic encapsulated, Class H high temperature magnet-wire. See page 3.200.7.

70-Size "E" Coil: Weight: 0.41 kg. (0.9 lbs.) Fully encapsulated with rugged external metal shell. IP69K rated. See page 3.400.13.

TO ORDER

