

ELECTRO-PROPORTIONAL VALVES—FLOW CONTROL

ZL70-31 Proportional, Bi-Directional Flow Control,

U.S. Patent
6,167,906

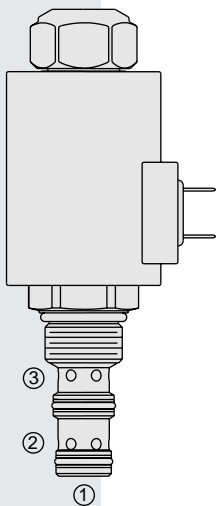

DESCRIPTION

A solenoid-operated, electrically-variable, three-port, pressure-compensated, spool-type, normally open when de-energized, proportional, bi-directional, flow control valve. An internal compensator spool provides compensated flow across the proportional orifice regardless of flow direction.

OPERATION

The ZL70-31 provides regulated flow from port ② to port ③, or regulated flow from port ③ to port ②. Port ① should be blocked. Regulated flow is inversely proportional to electric current applied to the solenoid.

Operation of Manual Override:

To Engage: Turn clockwise approximately 1 turn to reach start point. Continue another approximately 5 turns to full shift.

To Disengage: Turn counterclockwise approximately 6 turns until positive stop is found.

FEATURES

- Excellent linearity and hysteresis characteristics.
- Hardened spool and cage for long life.
- Optional coil voltages and terminations.
- Efficient wet armature construction.
- Manual Override option.

SYMBOLS

USASI/ISO:

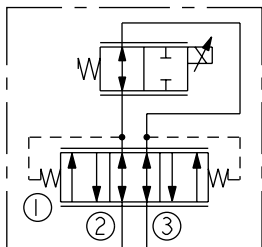

ABBREVIATED SYMBOL:

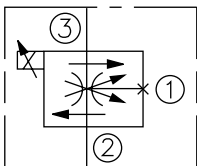

RATINGS

Maximum Operating Pressure: 240 bar (3500 psi)

Regulated Flow: Range A: 0–19 lpm (0–5.0 gpm); Range B: 0–9.5 lpm (0–2.5 gpm)

Internal Leakage: 0.38 lpm (0.10 gpm) maximum at zero current

Electrical: 2 standard voltage ratings

Coil Voltage	Threshold Current	Max. Control Current
12 VDC	50 ± 50 mA	1300 ± 100 mA
24 VDC	25 ± 25 mA	650 ± 50 mA

Temperature: -40 to 120°C with Buna N seals

Filtration: See page 9.010.1

Fluids: Mineral-based or synthetics with lubricating properties at viscosities of 7.4 to 420 cSt (50 to 2000 sus); See Temperature and Oil Viscosity, page 9.060.1

Installation: No restrictions; See page 9.020.1.

Cavity: VC10-3; See page 9.110.1

Cavity Tool: CT10-3X-XX; See page 8.600.1

Seal Kit: SK10-3X-MM; See page 8.650.1

PERFORMANCE

FLOW RANGE "A"
Regulated Flow vs. Current
240 bar/3500 psi Inlet
207 bar/3000 psi at Regulated Port
② to ③ ——— ③ to ② - - - -
12V Coil; 110 Hz PWM
32 cSt/150 sus oil at 40°C

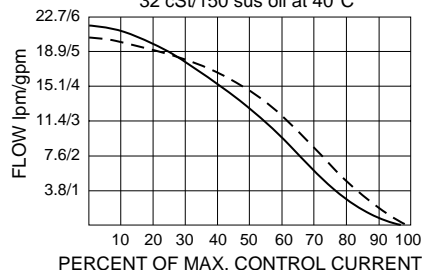

FLOW RANGE "A"
Regulated Flow vs. Pressure Drop
240 bar/3500 psi Inlet
② to ③ ——— ③ to ② - - - -
12V Coil; 110 Hz PWM
32 cSt/150 sus oil at 40°C

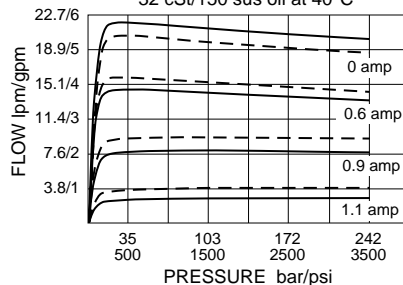

Recommended Electronic Controllers:
See page 2.001.1 or our Electronics catalog.

Normally Open

ZL70-31

PERFORMANCE (continued)

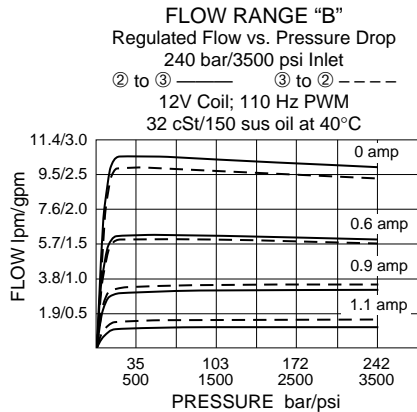
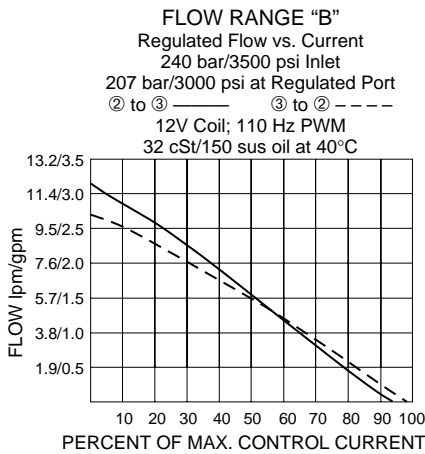

DIMENSIONS

U.S. Patent 6,167,906

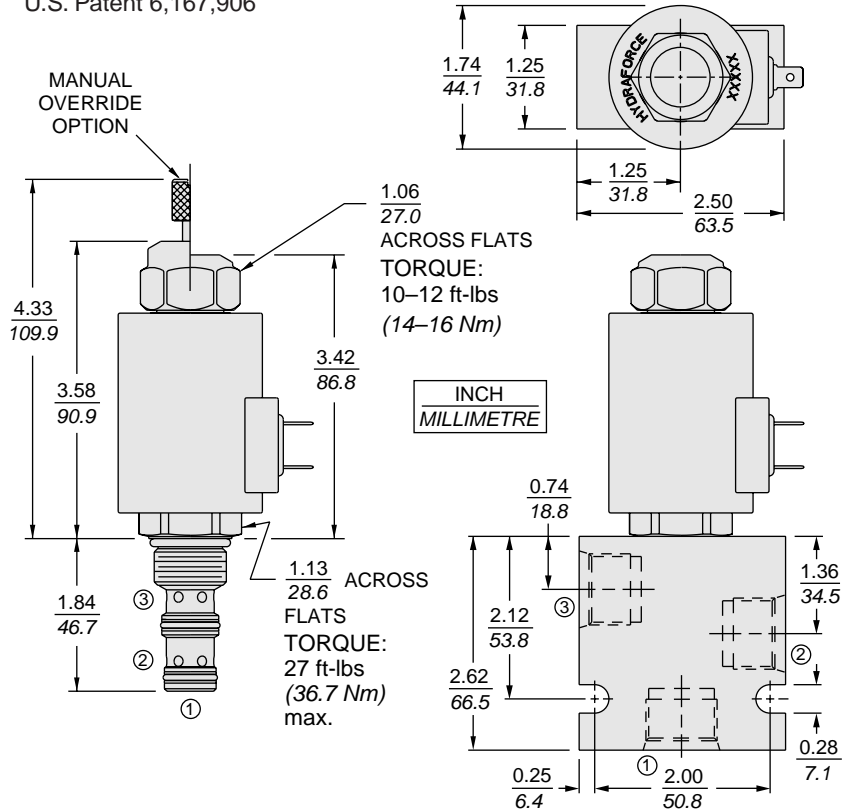

MATERIALS

Cartridge: Weight: 0.32 kg. (0.7 lbs.)
Steel with hardened work surfaces.
Zinc-plated exposed surfaces.
Buna N O-rings and polyester elastomer back-ups standard.

Standard Ported Body: Weight: 0.59 kg. (1.3 lbs.) Anodized high-strength 6061 T6 aluminum alloy, rated to 207 bar (3000 psi). Ductile iron bodies available; dimensions may differ. See page 8.010.1

70-Size "D" Coil: Weight: 0.32 kg. (0.7 lbs.) Unitized thermoplastic encapsulated, Class H high temperature magnet-wire. See page 3.200.7.

70-Size "E" Coil: Weight: 0.41 kg. (0.9 lbs.) Fully encapsulated with rugged external metal shell. IP69K rated. See page 3.400.13.

TO ORDER

ZL70-31	-	-	-	-	-	-	-
Range	A	B					
0–19 lpm (0–5.0 gpm)							
0–9.5 lpm (0–2.5 gpm)							
Option(s)							
None (Blank)							
Manual Override		M					
Porting							
Cartridge Only		0					
SAE 6		6T					
SAE 8		8T					
SAE 10		10T					
Terminations D-Coil							
DS							Dual Spades
DG							DIN 43650
DL							Leadwires (2)
DL/W							Leads w/Weatherpak® Connectors
Terminations E-Coil							IP69K Rated
ER							Deutsch DT04-2P
EY							Metri-Pack® 150
Voltage							Coils with internal diode are available. Consult factory.
0							Less Coil
12							12 VDC
24							24 VDC
Seals							
N							Buna N (Std.)
V							Fluorocarbon