

ELECTRO-PROPORTIONAL VALVES—PRESSURE CONTROLS

TS12-27 Proportional Electric Relief Valve

U.S. Patent
6,267,350

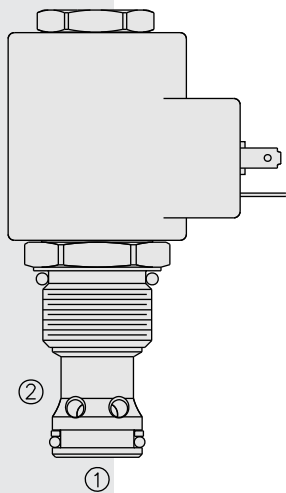

SYMBOLS

USAS/ISO:

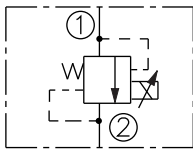

PERFORMANCE

Pressure Drop vs. Flow Characteristic
For Flow ① to ② with Coil Energized

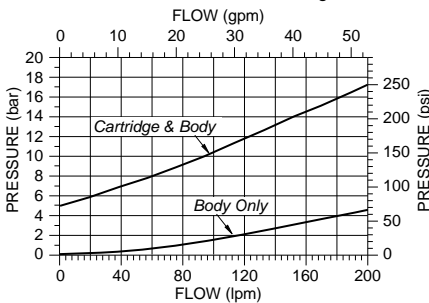

Relief Pressure vs. Current (DC) Characteristic, 200 Hz PWM
Relieving Pressure ① to ②

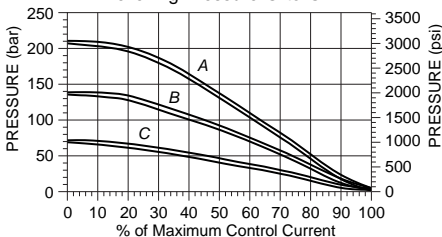

DESCRIPTION

A screw-in, cartridge-style, pilot-operated, spool-type hydraulic relief valve, which can be infinitely adjusted across a prescribed range using a variable electric input. Pressure output is inversely proportional to DC current input. This valve is intended for use as a pressure limiting device in demanding applications.

OPERATION

The **TS12-27** blocks flow from ① to ② until sufficient pressure is present at ① to open the pilot section by overcoming the induced spring force. With no current applied, the valve will relieve at ± 50 psi of the range maximum. Applying current to the coil proportionally decreases the pressure required to open the valve from ① to ②.

Note: This valve is ideal for hydraulic fan drive applications. Consult factory for electronic controllers specifically designed for fan drive applications.

FEATURES

- Hardened parts for long life.
- 12 and 24 volt coils standard.
- Industry common cavity.
- Optional waterproof E-Coils rated up to IP69K.

RATINGS

Maximum Operating Pressure: 241 bar (3500 psi)

Maximum Control Current: 1.10 amps for 12 VDC coil; 0.55 amps for 24 VDC coil

Relief Pressure Range from Zero to Maximum Control Current:

- A:** 207–10.34 bar (3000–150 psi)
- B:** 138–10.34 bar (2000–150 psi)
- C:** 69–10.34 bar (1000–150 psi)

Rated Flow: 186.3 lpm (50 gpm), $\Delta P=16.4$ bar (238 psi), Cartridge only,
① to ② coil energized

Maximum Pilot Flow: 0.76 lpm (.2 gpm)

Hysteresis: Less than 3%

Flow Path: Free Flow: ① to ② coil energized; Relieving: ① to ② coil de-energized

Temperature: -40 to 120°C (-40 to 250°F) with standard Buna N seals

Filtration: See page 9.010.1

Fluids: Mineral-based or synthetics with lubricating properties at viscosities of 7.4 to 420 cSt (50 to 2000 sus); See Temperature and Oil Viscosity, page 9.060.1

Installation Recommendation: When possible, the valve should be mounted below the reservoir oil level. This will maintain oil in the armature preventing trapped air instability. If this is not feasible, mount the valve horizontally for best results.

Cavity: VC12-2; See page 9.112.1; **Cavity Tool:** CT12-2XX; See page 8.600.1

Seal Kit: SK12-2X-B; See page 8.650.1

Coil Nut: Part No. 4540550;

For E-coils manufactured prior to 1-1-04, see page 3.400.1 for coil nut info.

Typical Relief Pressure vs. Flow Characteristic
Typical Relieving Pressure ① to ②
at Various %'s of Maximum Control Current
Pressure Range "A" (207 bar/3000 psi); Cartridge in Body

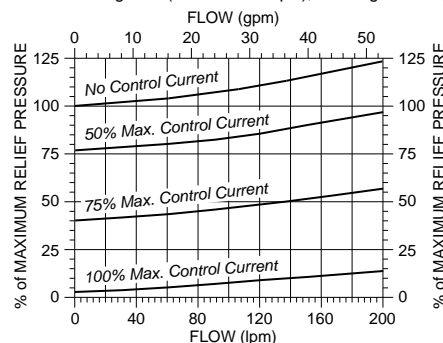

Recommended Electronic Controllers:

Model **EFDR2** Multi-Input Fan Drive Controller.
For more information go to:
<http://www.hydraforce.com/Electro/fandrive.htm>

or
Recommended Electronic Controllers
catalog page 2.001.1 (Table 2)

DIMENSIONS

U.S. Patent 6,267,350

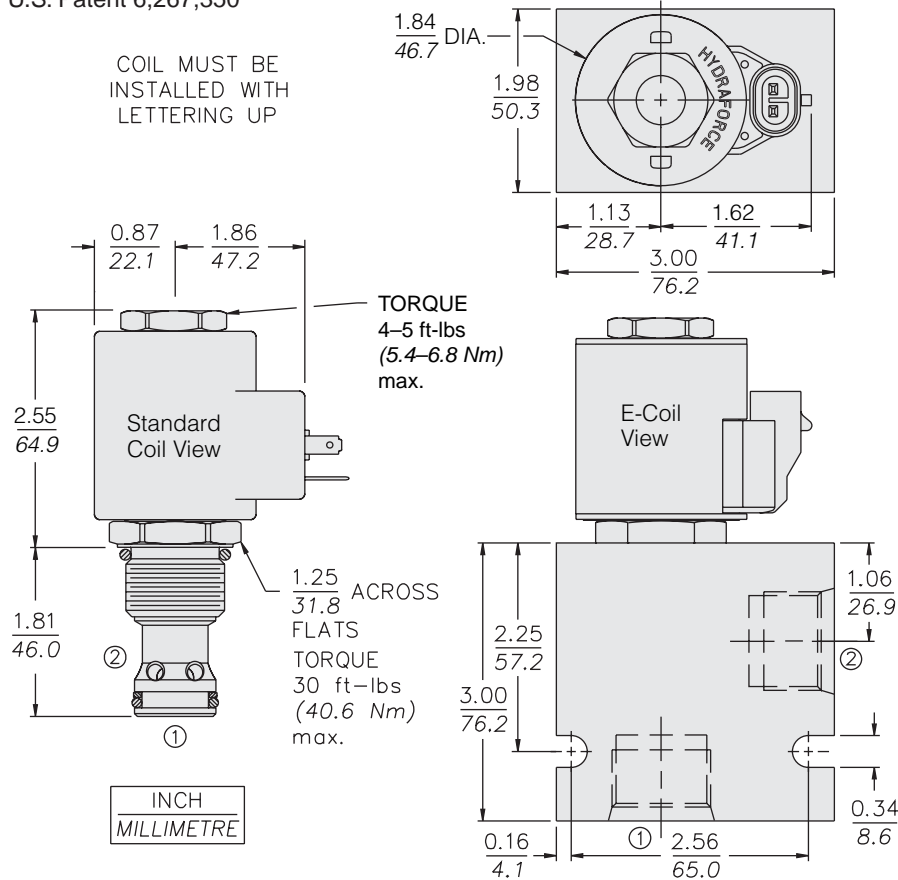

MATERIALS

Cartridge: Weight: 0.56 kg. (1.23 lbs.)
Steel with hardened work surfaces.
Zinc-plated exposed surfaces.
Buna N O-rings and TFE back-ups standard.

Standard Ported Body: Weight: 0.36 kg. (0.80 lbs.) Anodized high-strength 6061 T6 aluminum alloy, rated to 207 bar (3000 psi). Ductile iron bodies available; dimensions may differ. See page 8.012.1

Standard Coil: Weight: 0.32 kg. (0.7 lbs.); Unitized thermoplastic encapsulated, Class H high temperature magnet-wire. See page 3.200.1.

E-Coil: Weight: 0.41 kg. (0.9 lbs.) Fully encapsulated with rugged external metal shell. Rated up to IP69K with integral connectors.
Note: See page 3.400.1 for all E-Coil retrofit applications.

TO ORDER

TS12-27 - - -

Maximum Relief Pressure
207 bar (3000 psi) **A**
140 bar (2000 psi) **B**
70 bar (1000 psi) **C**

Porting
Cartridge Only **0**
SAE 10 **10T**
SAE 12 **12T**
1/2 in. BSP* **4B**
3/4 in. BSP* **6B**

*BSP Body; U.K. Mfr. Only

Seals
Buna N (Std.) **N**
Fluorocarbon **V**

Termination Std. Coil

DS Dual Spades
DG DIN 43650
DL Leadwires (2)
DL/W Leads w/Weatherpak® Connectors
DR Deutsch DT04-2P

Termination E-Coil

ER Deutsch DT04-2P (IP69K Rated)
EY Metri-Pack® 150 (IP69K Rated)

Voltage

0 Less Coil
10 10 VDC (1.30 amps max.)
12 12 VDC (1.10 amps max.)
20 20 VDC (0.65 amps max.)
24 24 VDC (0.55 amps max.)

Coils with internal diode are available. Consult factory.