

HSV10-21 HyPerformance™ Poppet, 2-Way, N.O.

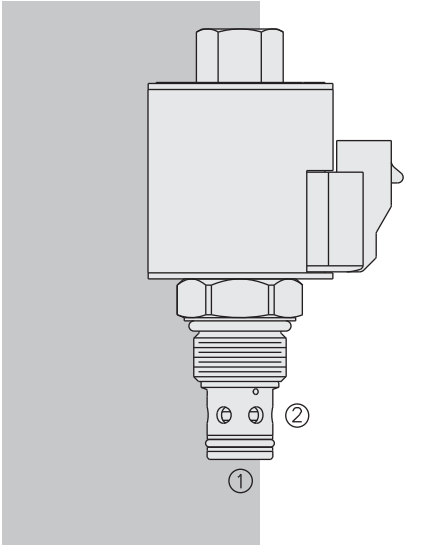

DESCRIPTION

A solenoid-operated, 2-way, normally open, poppet-type, screw-in hydraulic cartridge valve, designed to function as a load holding or blocking valve in high pressure applications requiring low internal leakage.

OPERATION

When de-energized, the HSV10-21 allows flow from 2 to 1 while flow from 1 to 2 is severely restricted in this mode.

When energized, the valve's poppet closes on its seat, blocking flow from 2 to 1. In this mode the cartridge will allow 1 to 2 flow after overcoming the actuator and spring forces (see performance graph).

FEATURES

- Continuous-duty rated solenoid.
- Hardened seat for long life and low leakage.
- Optional coil voltages and terminations.
- Efficient wet-armature construction.
- Cartridges are voltage interchangeable.
- Waterproof E-Coils rated up to IP69K.
- 1000-hour salt-spray rated solenoid tubes and coils.
- Unitized, molded coil design.
- All HyPerformance products are tested to the rigorous standards of the NFPA specification T2.6.1.
- All HyPerformance valves are tested at a verification level of 90% and an assurance of 99%.

SYMBOL

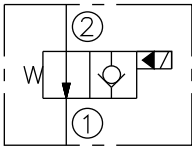

RATINGS

Operating Pressure: 350 bar (5075 psi); 10% Cycle Life: 420 bar (6090 psi)

Note: All HyPerformance products are tested for 900K cycles at 350 bar and 100K cycles at 420 bar.

Burst Pressure: 1380 bar (20,000 psi)

Flow: Up to 75.7 lpm (20 gpm)

Internal Leakage: 0.25 cc/minute (5 drops/minute) max. with 350 bar (5075 psi) at port 2.

Coil Duty Rating: Continuous from 85% to 115% of nominal voltage

Initial Coil Current Draw at 20°C: 1.7 amps at 12 VDC; 0.85 amps at 24 VDC

Temperature: -54° to 107°C (-65° to 225°F) with Urethane seals

Filtration: See page 9.010.1

Fluids: Mineral-based or synthetics with lubricating properties at viscosities of 7.4 to 420 cSt (50 to 2000 sus); See Temperature and Oil Viscosity, page 9.060.1

Installation: No restrictions; See page 9.020.1

Cavity: HVC10-2; See page 9.110.1

Cavity Tool: HCT10-2xx; See page 8.600.1

Seal Kit: SK10-2U-O; See page 8.650.1

Coil Nut: Part No. 4555250

PERFORMANCE (Cartridge Only)

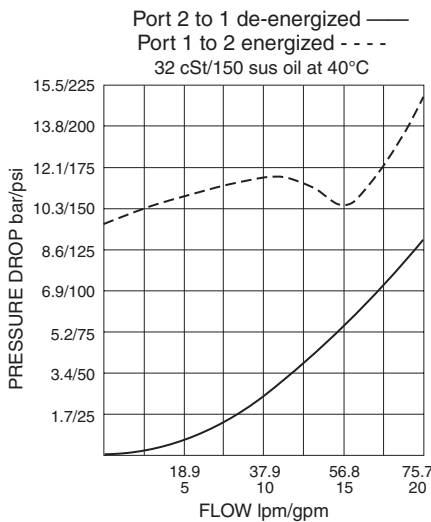

DIMENSIONS

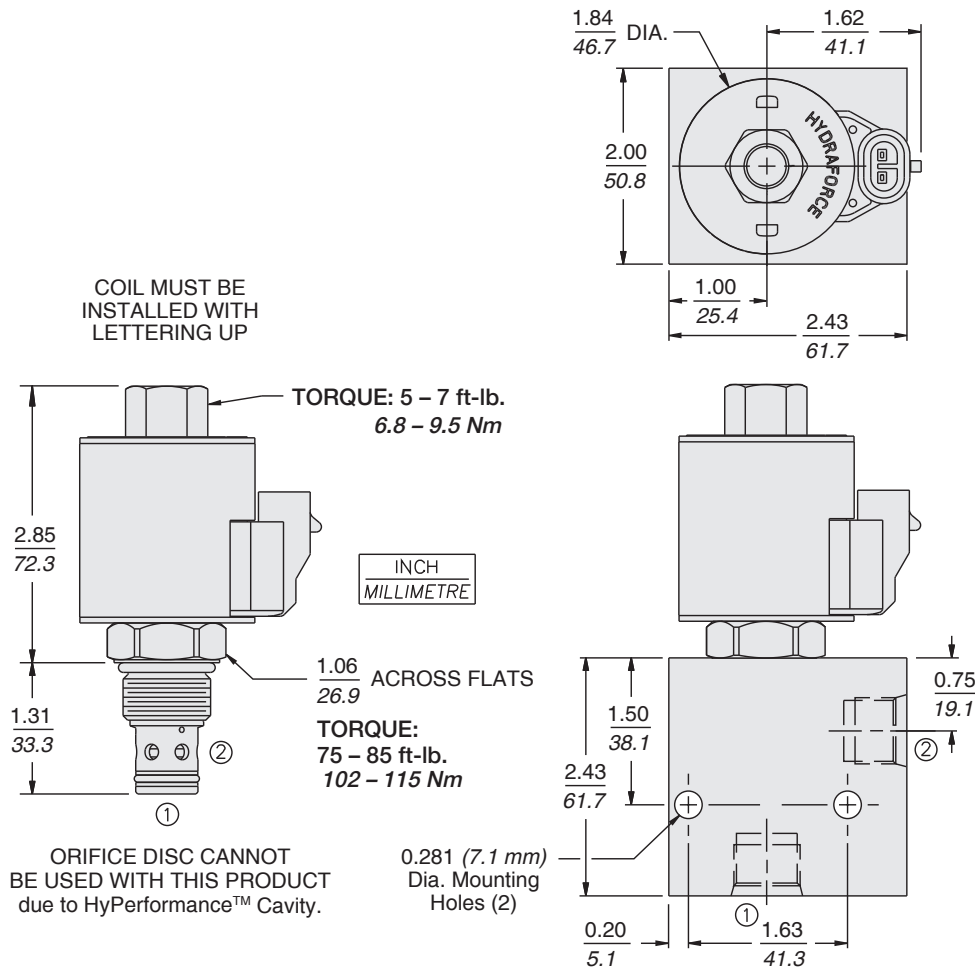

MATERIALS

Cartridge: Weight: 0.19 kg. (0.41 lbs.); Steel with hardened work surfaces. Zinc-plated exposed surfaces. Urethane O-rings without back-up standard.

Ported Body: Weight: 1.19 kg. (2.62 lbs.); HyPerformance™ Ductile iron (code 'D') standard. Rated to 345 bar (5000 psi).

E-Coil: Weight: 0.41 kg. (0.9 lbs.); Fully encapsulated with rugged external metal shell. Rated up to IP69K with integral connectors. See page 3.400.1.

TO ORDER

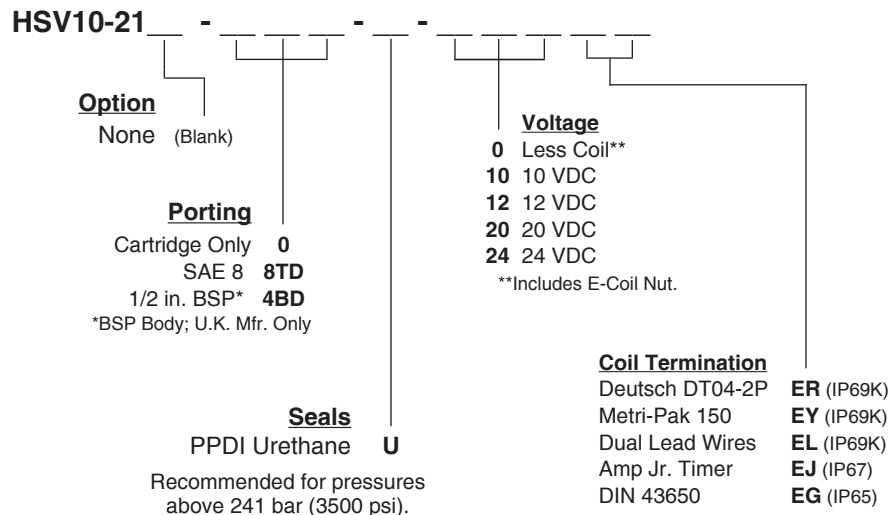

For Coils with Zener Diode, add "Z" to option code. For example: "ERZ". Not available on all models. See coil option info. on page 3.400.1