

SV16-22 Poppet, 2-Way, Normally Closed

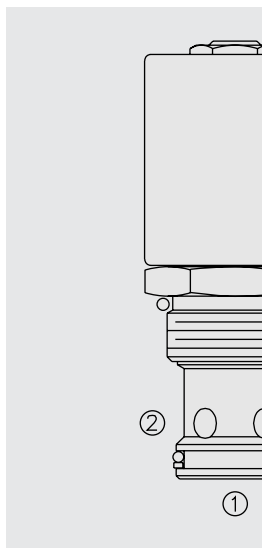

DESCRIPTION

A solenoid-operated, 2-way, normally closed, poppet-type, screw-in hydraulic cartridge valve, designed to function as a load-holding or blocking valve in applications requiring low internal leakage.

OPERATION

When de-energized, the **SV16-22** acts as a check valve, allowing flow from ① to ②, while blocking flow from ② to ①.

When energized, the poppet lifts to open the ② to ① flow path. In this mode, flow is also allowed from ① to ②.

Operation of Manual Override Option: To override, push button in, twist counter-clockwise 180° and release. In this position, the valve will remain open.

To return to normal operation, push button in, twist clockwise 180° and release. Override will be detented in this position.

FEATURES

- Continuous-duty rated solenoid.
- Hardened seat for long life and low leakage.
- Optional coil voltages and terminations.
- Efficient wet-armature construction.
- Cartridges are voltage interchangeable.
- Unitized, molded coil design.
- Manual override option.
- Optional waterproof E-Coils rated up to IP69K.
- Industry common cavity.

RATINGS

Operating Pressure: 207 bar (3000 psi); Under certain operating conditions, this valve may be used at higher pressures; consult factory.

Proof Pressure: 390 bar (5700 psi)

Flow: See Performance Chart

Internal Leakage: 0.15 cc/minute (3 drops/minute) max. at 207 bar (3000 psi)

Temperature: -40 to 120°C with standard Buna seals

Coil Duty Rating: Continuous from 85% to 115% of nominal voltage

Initial Coil Current Draw at 20°C: Standard Coil: 1.67 amps at 12 VDC;
0.18 amps at 115 VAC (full wave rectified).

E-Coil: 1.7 amps at 12 VDC; 0.85 amps at 24 VDC

Minimum Pull-in Voltage: 85% of nominal at 207 bar (3000 psi)

Filtration: See page 9.010.1

Fluids: Mineral-based or synthetics with lubricating properties at viscosities of 7.4 to 420 cSt (50 to 2000 sus); See Temperature and Oil Viscosity, page 9.060.1

Installation: No restrictions; See page 9.020.1

Cavity: VC16-2; See page 9.116.1

Cavity Tool: CT16-2XX; See page 8.600.1

Seal Kit: SK16-2X-T; See page 8.650.1

Coil Nut: Part No. 7004400;

For E-coils manufactured prior to 1-1-04, see page 3.400.1 for coil nut info.

SYMBOLS

USASI:

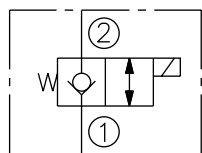

ISO:

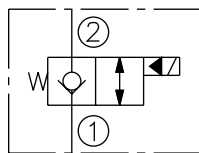

PERFORMANCE (Cartridge Only)

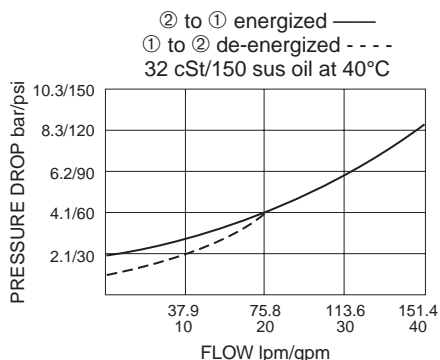

DIMENSIONS

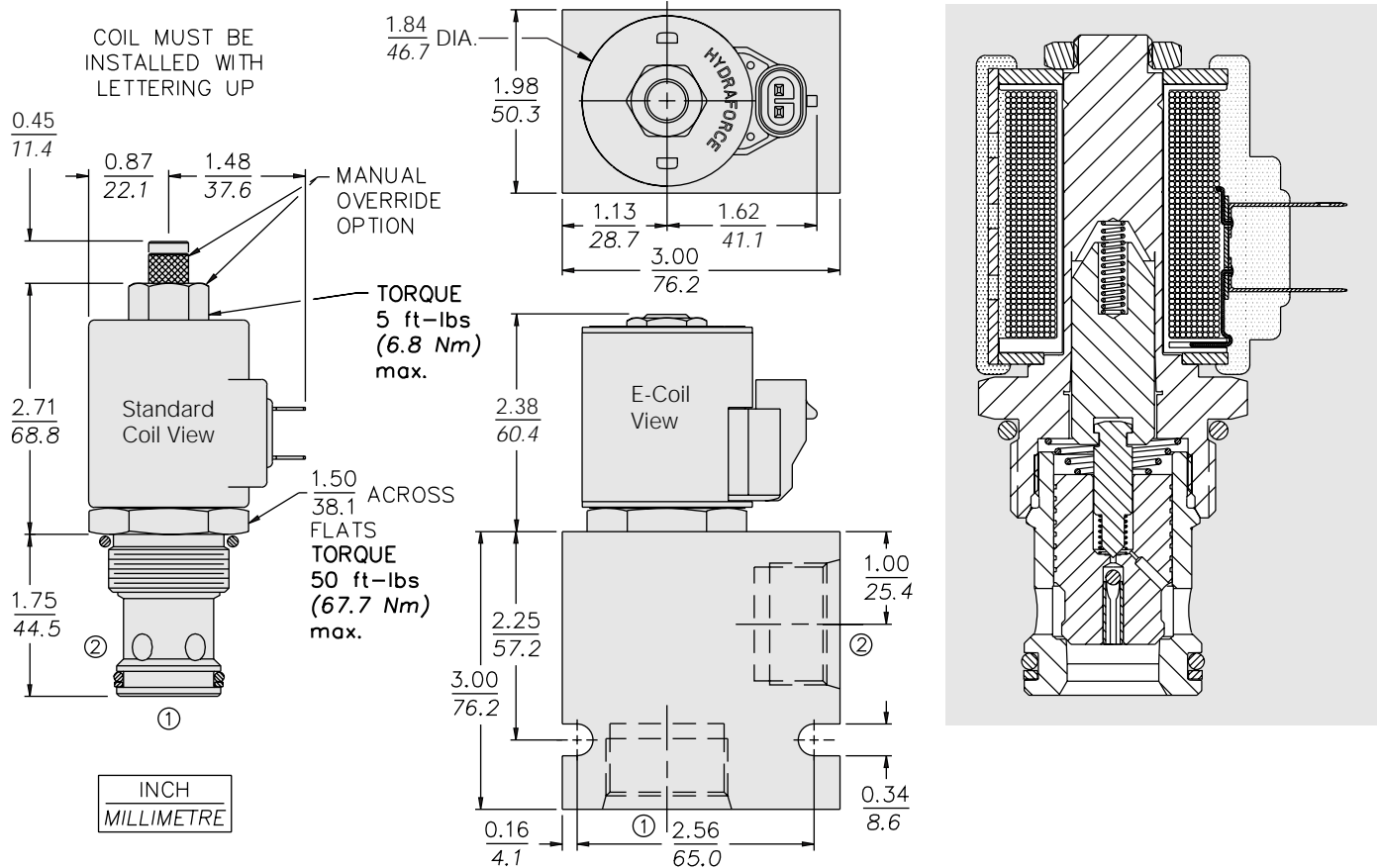

MATERIALS

Cartridge: Weight: 0.31 kg. (0.69 lbs.); Steel with hardened work surfaces. Zinc-plated exposed surfaces. Buna N O-rings and polyester elastomer back-up standard.

Standard Ported Body: Weight: 0.57 kg. (1.25 lbs.); Anodized high-strength 6061 T6 aluminum alloy, rated to 207 bar (3000 psi). Ductile iron bodies available; dimensions may differ. See page 8.016.1.

Standard Coil: Weight: 0.27 kg. (0.60 lbs.); Unitized thermoplastic encapsulated, Class H high temperature magnetwire. See page 3.200.1

E-Coil: Weight: 0.41 kg. (0.9 lbs.); Fully encapsulated with rugged external metal shell. Rated up to IP69K with integral connectors.

Note: See page 3.400.1 for all E-Coil retrofit applications.

TO ORDER

SV16-22

Option	Voltage Std. Coil	Termination (VDC) Std. Coil
None (Blank)	0 Less Coil**	DS Dual Spades
Manual Override M	10 10 VDC [†]	DG DIN 43650
Manual Override Y	12 12 VDC	DL Leadwires (2)
Manual Override J	24 24 VDC	DLW Leads w/Weatherpak® Connectors
For Manual Override options see page 1.001.1	36 36 VDC	DR Deutsch DT04-2P
	48 48 VDC	
	24 24 VAC	Termination (VAC) Std. Coil
Porting	115 115 VAC	AG DIN 43650
Cartridge Only 0	230 230 VAC	AP 1/2 in. Conduit
SAE 12 12T	**Includes Std. Coil Nut	Termination (VDC) E-Coil
SAE 16 16T	† DS, DW or DL terminations only.	ER Deutsch DT04-2P (IP69K Rated)
3/4 in. BSP* 6B		EY Metri-Pack® 150 (IP69K Rated)
1 in. BSP* 8B		
*BSP Body; U.K. Mfr. Only	E-Coil	
	10 10 VDC	
Seals	12 12 VDC	
Buna N (Std.) N	20 20 VDC	
Fluorocarbon V	24 24 VDC	