

## SV38-30 Spool, 3-Way

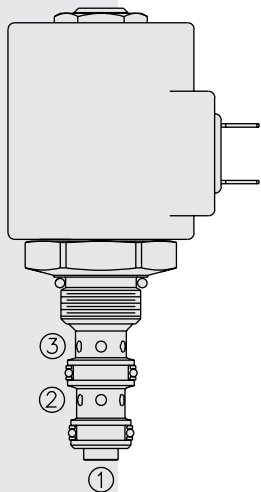

## SYMBOLS

## USASI/ISO:

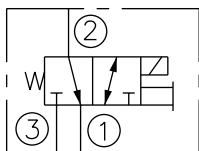

## PERFORMANCE (Cartridge Only)

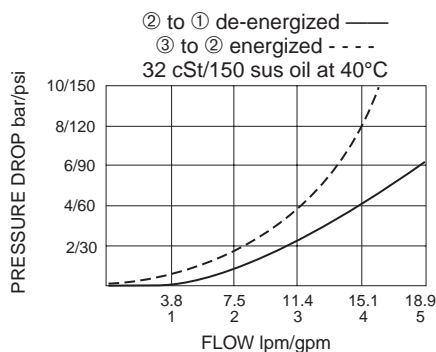

## DESCRIPTION

A solenoid-operated, three-way, direct-acting, spool-type, screw-in hydraulic directional valve.

## OPERATION

When de-energized, the **SV38-30** allows flow from ② to ①, while blocking flow at ③. When energized, the cartridge's spool shifts to open from ③ to ②, while blocking flow out ①. While port ① may be fully pressurized, it is not intended to be used as the inlet.

**Operation of Manual Override Option:** To override, push button in and twist counterclockwise 180°. The internal spring will push the button out. In this position, the valve may be only partially shifted. To assure full override shift, pull the button out to its fullest extension and hold it in this position.

To return to normal valve function, push button in, twist clockwise 180°, and release. Override will be detented in this position.

## FEATURES

- Continuous-duty rated solenoid.
- Hardened precision spool and cage for long life.
- Optional coil voltages and terminations.
- Efficient wet-armature construction.
- Cartridges are voltage interchangeable.
- All ports may be fully pressurized.
- Manual override option.
- Optional waterproof E-Coils rated up to IP69K.
- Unitized, molded coil design.
- Fully guided spool.
- Compact size.

## RATINGS

**Operating Pressure:** 207 bar (3000 psi)

**Flow:** See Performance Chart

## Internal Leakage:

- Port ③ (De-energized): 82 cc/minute (5 cu. in./minute) max. at 207 bar (3000 psi);
- Port ① (Energized): 164 cc/minute (10 cu. in./minute) max. at 207 bar (3000 psi)

**Temperature:** -40 to 120°C with standard Buna seals

**Coil Duty Rating:** Continuous from 85% to 115% of nominal voltage

**Initial Coil Current Draw at 20°C:** Standard Coil: 1.67 amps at 12 VDC;  
0.18 amps at 115 VAC (full wave rectified).

E-Coil: 1.7 amps at 12 VDC; 0.85 amps at 24 VDC

**Minimum Pull-in Voltage:** 85% of nominal at 207 bar (3000 psi)

**Filtration:** See page 9.010.1

**Fluids:** Mineral-based or synthetics with lubricating properties at viscosities of 7.4 to 420 cSt (50 to 2000 sus); See Temperature and Oil Viscosity, page 9.060.1

**Installation:** See Note on Dimension Drawing

**Cavity:** VC08-3, Variation "A"; See page 9.108.1

**Cavity Tool:** CT08-3XX; See page 8.600.1

**Seal Kit:** SK08-3X-MM; See page 8.650.1

**Coil Nut:** Part No. 7004400;

For E-coils manufactured prior to 1-1-04, see page 3.400.1 for coil nut info.

**DIMENSIONS**

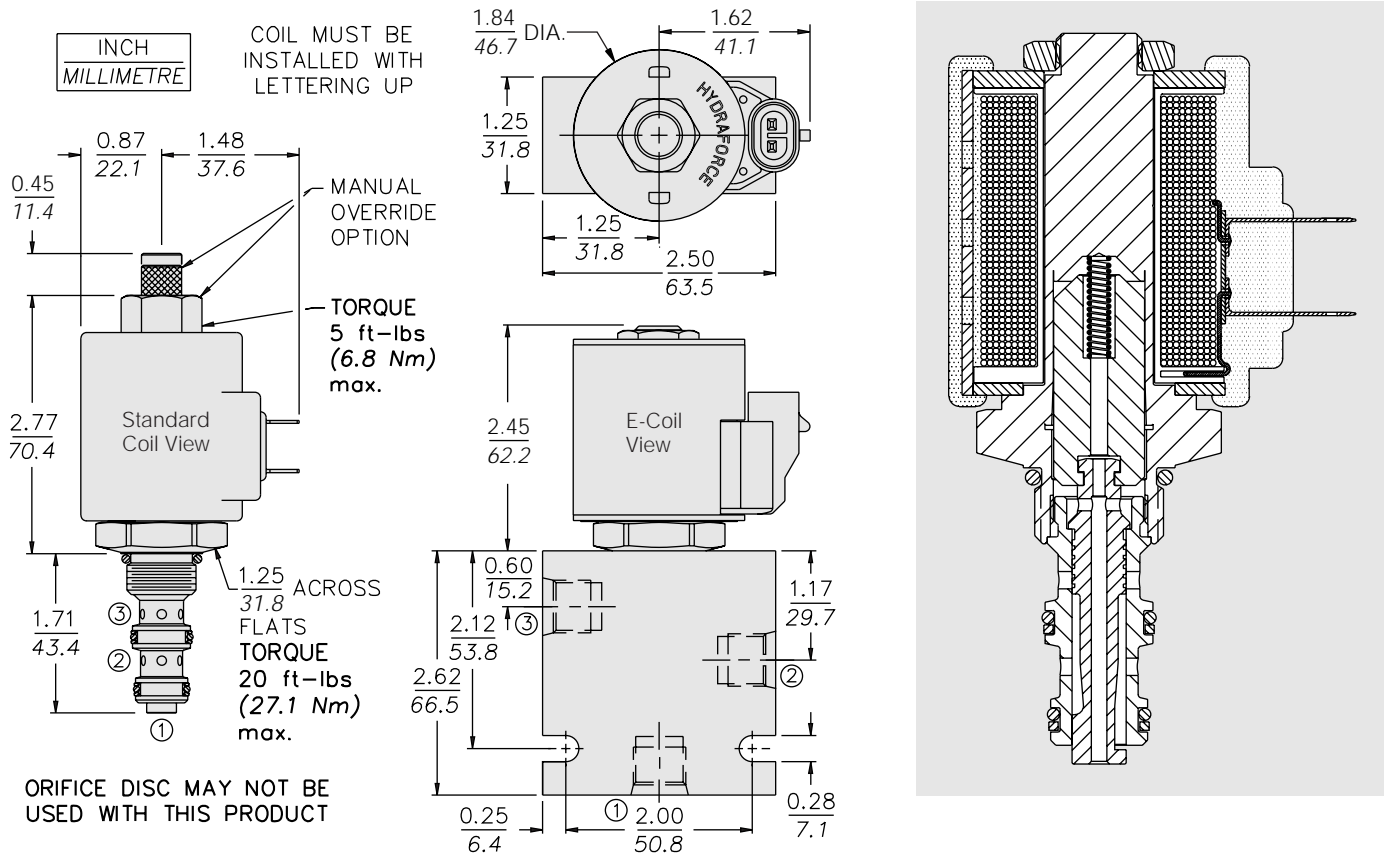

**MATERIALS**

**Cartridge:** Weight: 0.13 kg. (0.28 lbs.); Steel with hardened work surfaces. Zinc-plated exposed surfaces. Buna N O-rings and polyester elastomer back-up standard.

**Standard Ported Body:** Weight: 0.27 kg. (0.60 lbs.); Anodized high-strength 6061 T6 aluminum alloy, rated to 207 bar (3000 psi). Ductile iron bodies available; dimensions may differ. See page 8.008.1.

**Standard Coil:** Weight: 0.27 kg. (0.60 lbs.); Unitized thermoplastic encapsulated, Class H high temperature magnetwire. See page 3.200.1.

**E-Coil:** Weight: 0.41 kg. (0.9 lbs.); Fully encapsulated with rugged external metal shell. Rated up to IP69K with integral connectors. **Note: See page 3.400.1 for all E-Coil retrofit applications.**

**TO ORDER**

**SV38-30**

<b>Option</b>	<b>None</b> (Blank)	<b>Voltage</b>	<b>Termination (VDC)</b>
		<b>Std. Coil</b>	<b>Std. Coil</b>
Manual Override	<b>M</b>	<b>0</b> Less Coil**	<b>DS</b> Dual Spades
Manual Override	<b>Y</b>	<b>10</b> 10 VDC <sup>†</sup>	<b>DG</b> DIN 43650
Manual Override	<b>J</b>	<b>12</b> 12 VDC	<b>DL</b> Leadwires (2)
	For Manual Override options see page 1.001.1	<b>24</b> 24 VDC	<b>DL/W</b> Leads w/Weatherpak® Connectors
		<b>36</b> 36 VDC	<b>DR</b> Deutsch DT04-2P
		<b>48</b> 48 VDC	
<b>Porting</b>		<b>24</b> 24 VAC	<b>Termination (VAC)</b>
Cartridge Only	<b>0</b>	<b>115</b> 115 VAC	<b>Std. Coil</b>
SAE 6	<b>6T</b>	<b>230</b> 230 VAC	<b>AG</b> DIN 43650
1/4 in. BSP*	<b>2B</b>		<b>AP</b> 1/2 in. Conduit
*BSP Body; U.K. Mfr. Only		**Includes Std. Coil Nut	<b>Termination (VDC)</b>
		<sup>†</sup> DS, DW or DL terminations only.	<b>E-Coil</b>
<b>Seals</b>		<b>E-Coil</b>	<b>ER</b> Deutsch DT04-2P (IP69K Rated)
Buna N (Std.)	<b>N</b>	<b>10</b> 10 VDC	<b>EY</b> Metri-Pack® 150 (IP69K Rated)
Fluorocarbon	<b>V</b>	<b>12</b> 12 VDC	
		<b>20</b> 20 VDC	
		<b>24</b> 24 VDC	

Coils with internal diode are available. Consult factory.