

SV10-33 Spool, 3-Way

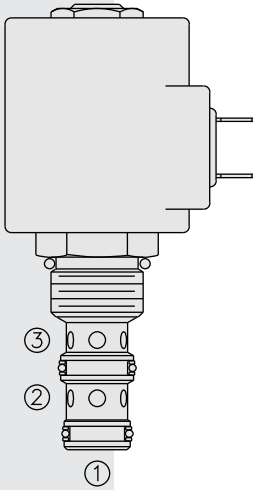

SYMBOLS

USAS/ISO:

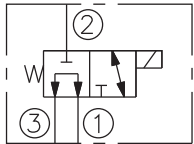

PERFORMANCE (Cartridge Only)

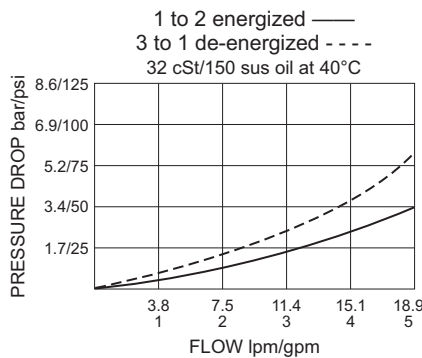

DESCRIPTION

A solenoid-operated, 3-way, direct-acting, spool-type, screw-in hydraulic cartridge valve.

OPERATION

When de-energized, the **SV10-33** allows flow from 3 to 1, while blocking flow at 2. When energized, the cartridge's spool shifts to open from 2 to 1, while blocking at 3. While port 1 may be fully pressurized, it is not intended to be used as the inlet.

Operation of Manual Override Option: To override, push button in and twist counterclockwise 180°. The internal spring will push the button out. In this position, the valve may be only partially shifted. To assure full override shift, pull the button out to its fullest extension and hold it in this position.

To return to normal valve function, push button in, twist clockwise 180°, and release. Override will be detented in this position.

FEATURES

- Continuous-duty rated solenoid.
- Hardened precision spool and cage for long life.
- Optional coil voltages and terminations.
- Efficient wet-armature construction.
- All ports may be fully pressurized.
- Cartridges are voltage interchangeable.
- Manual override option.
- Optional waterproof E-Coils rated up to IP69K.
- Unitized, molded coil design.
- Industry common cavity.

RATINGS

Operating Pressure: 207 bar (3000 psi)

Proof Pressure: 350 bar (5075 psi)

Flow: 18.9 lpm (5 gpm) max.

Internal Leakage: 82 cc/minute (5 cu. in./minute) max. at 207 bar (3000 psi)

Temperature: -40 to 120°C with standard Buna seals

Coil Duty Rating: Continuous from 85% to 115% of nominal voltage

Initial Coil Current Draw at 20°C: Standard Coil: 1.67 amps at 12 VDC;

0.18 amps at 115 VAC (full wave rectified).

E-Coil: 1.7 amps at 12 VDC; 0.85 amps at 24 VDC

Minimum Pull-in Voltage: 85% of nominal at 207 bar (3000 psi)

Filtration: See page 9.010.1

Fluids: Mineral-based or synthetics with lubricating properties at viscosities of 7.4 to 420 cSt (50 to 2000 sus); See Temperature and Oil Viscosity, page 9.060.1

Installation: No restrictions; See page 9.020.1

Cavity: VC10-3, See page 9.110.1

Cavity Tool: CT10-3XX; See page 8.600.1

Seal Kit: SK10-3X-MM; See page 8.650.1

Coil Nut: Part No. 7004400;

For E-coils manufactured prior to 1-1-04, see page 3.400.1 for coil nut info.

DIMENSIONS

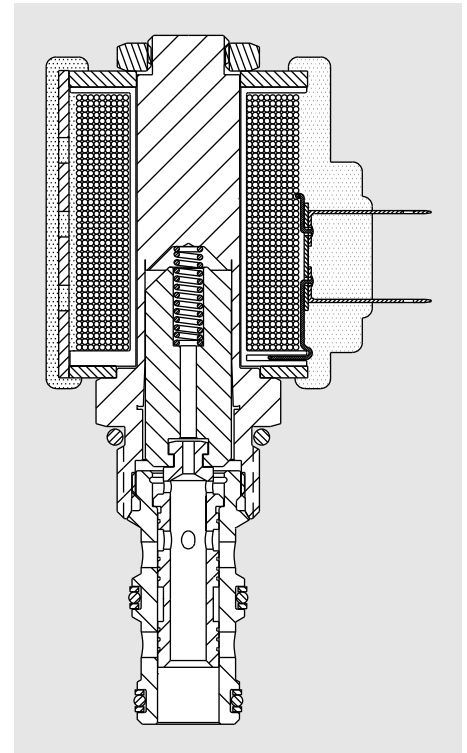
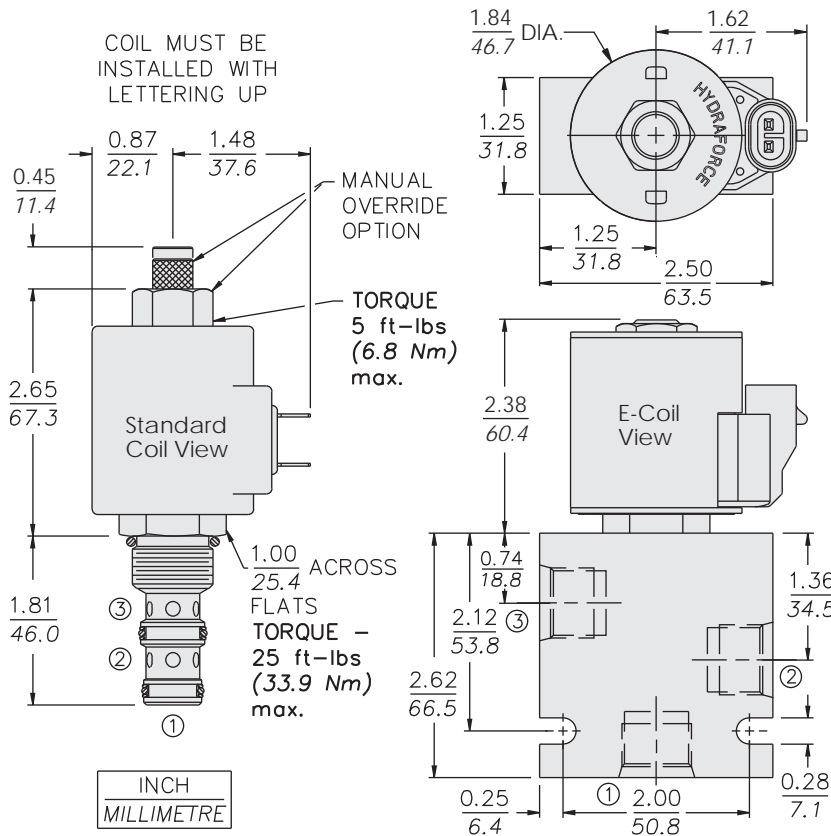

MATERIALS

Cartridge: Weight: 0.14 kg. (0.30 lbs.); Steel with hardened work surfaces. Zinc-plated exposed surfaces. Buna N O-rings and polyester elastomer back-up standard.

Standard Ported Body: Weight: 0.36 kg. (0.80 lbs.); Anodized high-strength 6061 T6 aluminum alloy, rated to 207 bar (3000 psi). Ductile iron bodies available; dimensions may differ. See page 8.010.1.

Standard Coil: Weight: 0.27 kg. (0.60 lbs.); Unitzated thermoplastic encapsulated, Class H high temperature magnetwire. See page 3.200.1.

E-Coil: Weight: 0.41 kg. (0.9 lbs.); Fully encapsulated with rugged external metal shell. Rated up to IP69K with integral connectors. See page 3.400.1.

TO ORDER

SV10-33

| | | | |
|--|--------------|------------------|-----------------------------------|
| Option | None (Blank) | Voltage | |
| Manual Override | M | Std. Coil | |
| Manual Override | Y | 0 | Less Coil** |
| Manual Override | J | 10 | 10 VDC† |
| For Manual Override options see page 1.001.1 | | 12 | 12 VDC |
| | | 24 | 24 VDC |
| | | 36 | 36 VDC |
| | | 48 | 48 VDC |
| | | 24 | 24 VAC |
| | | 115 | 115 VAC |
| | | 230 | 230 VAC |
| | | | **Includes Std. Coil Nut |
| | | | † DS, DW or DL terminations only. |
| Porting | | E-Coil | |
| Cartridge Only | 0 | 10 | 10 VDC |
| SAE 6 | 6T | 12 | 12 VDC |
| SAE 8 | 8T | 20 | 20 VDC |
| 1/4 in. BSP* | 2B | 24 | 24 VDC |
| 3/8 in. BSP* | 3B | | |
| *BSP Body; U.K. Mfr. Only | | | |
| Seals | | | |
| Buna N (Std.) | N | | |
| Fluorocarbon | V | | |

| | | |
|-------------------------|-------------------|------------------|
| Coil Termination | E-Coil | D-Coil |
| Deutsch DT04-2P | ER (IP69K) | DR (IP65) |
| Metri-Pack® 150 | EY (IP69K) | DY (IP65) |
| Dual Lead Wires | EL (IP69K) | DL (IP65) |
| Amp Jr. Timer | EJ (IP67) | — |
| DIN 43650 | EG (IP65) | DG (IP65) |
| Dual Spades | — | DS (IP65) |

For Coils with Zener Diode, add "Z" to option code. For example: "ER/Z". Not available on all models. See coil option info. on pages 3.200.1 & 3.400.1