

## SV20-S38 Poppet-Type High-Flow Blocking, N.C.

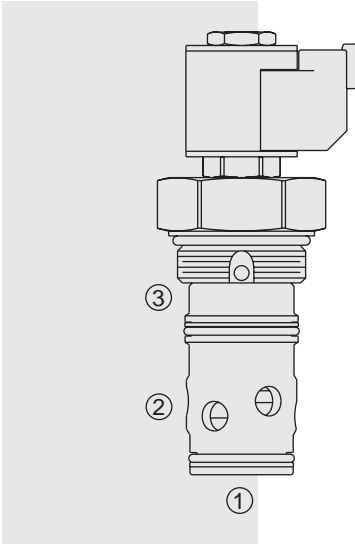

### DESCRIPTION

A solenoid-operated, normally closed, poppet-type, screw-in hydraulic cartridge valve, designed to operate as a bidirectional load-holding or blocking valve in high flow circuits requiring low internal leakage.

### OPERATION

When the **SV20-S38** is de-energized, it functions as a check valve, allowing flow from ① to ② while blocking flow from ② to ①. When energized, the poppet lifts to open the ② to ① flow path while also allowing flow from ① to ②. Port ③ is typically connected to the reservoir.

**Operation of Manual Override Feature:** To override, push button in and twist counterclockwise 180°. The internal spring will push the button out. In this position, the valve may be only partially shifted. To assure full override shift, pull the button out to its fullest extension and hold it in this position. To return to normal valve function, push button in, twist clockwise 180° and release. Override will be detented in this position.

### FEATURES

- Continuous-duty rated solenoid.
- Hardened precision spool and cage.
- Optional coil voltages and terminations.
- Efficient wet-armature construction.
- Cartridges are voltage interchangeable.
- Manual override option.
- Optional E-Coils rated up to IP69K.
- Unitized, molded coil design.
- Industry common cavity.

### SYMBOLS

#### USAS/ISO:

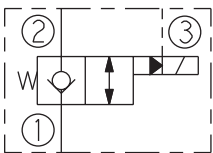

#### Expanded:

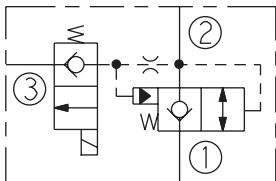

### RATINGS

**Operating Pressure:** 293 bar (4250 psi)

**Flow:** 378 lpm (100 gpm) max.

**Internal Leakage:** 1 ml/minute (0.06 cu. in./minute) max. at 293 bar (4250 psi)

**Temperature:** -40 to 100°C with standard Buna seals

**Coil Duty Rating:** Continuous from 85% to 115% of nominal voltage

**Initial Coil Current Draw at 20°C:** Standard Coil: 1.2 amps at 12 VDC;

0.13 amps at 115 VAC (full wave rectified).

E-Coil: 1.4 amps at 12 VDC; 0.7 amps at 24 VDC

**Minimum Pull-in Voltage:** 85% of nominal at 207 bar (3000 psi)

**Temperature:** -40 to 120°C with standard Buna seals

**Filtration:** See page 9.010.1

**Fluids:** Mineral-based or synthetics with lubricating properties at viscosities of 7.4 to 420 cSt (50 to 2000 sus); See Temperature and Oil Viscosity, page 9.060.1

**Installation:** No restrictions; See page 9.020.1

**Cavity:** VC20-S3, Variation "A"; See page 9.120.1

**Cavity Tool:** CT20-S3xx; See page 8.600.1

**Seal Kit:** SK20-S3x-MM; See page 8.650.1

**Coil Nut:** Part No. 7004400;

For E-coils manufactured prior to 1-1-04, see page 3.400.1 for coil nut info.

### PERFORMANCE (Cartridge Only)

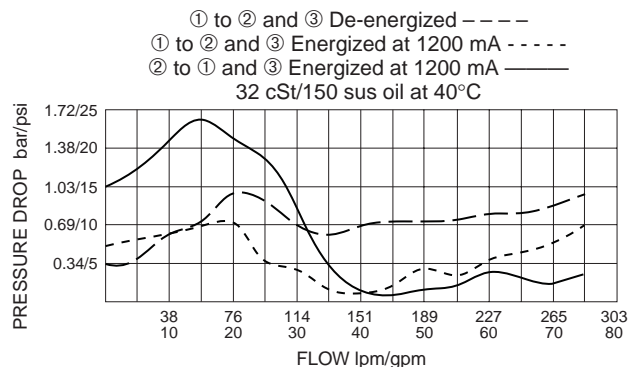

**DIMENSIONS**

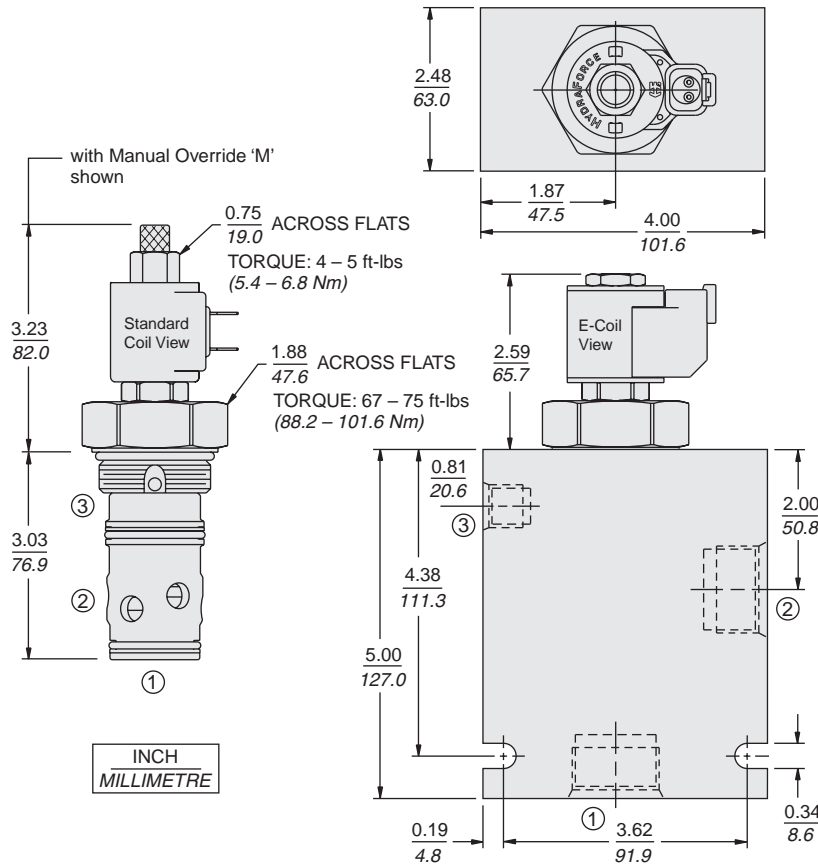

**MATERIALS**

**Cartridge:** Weight: 0.74 kg. (1.63 lbs.)  
Steel with hardened work surfaces.  
Zinc-plated exposed surfaces.  
Buna N O-rings and polyester elastomer back-ups standard.

**Standard Ported Body:** Weight: 1.65 kg. (3.65 lbs.) Anodized high-strength 6061 T6 aluminum alloy, rated to 207 bar (3000 psi). Ductile iron bodies can be made available; dimensions may differ. See page 8.020.1.

**Standard Coil:** Weight: 0.11 kg. (0.25 lbs.); Unitized thermoplastic encapsulated, Class H high temperature magnetwire. See page 3.200.1

**E-Coil:** Weight: 0.14 kg. (0.3 lbs.); Perfect wound, fully encapsulated with rugged external metal shell; Rated up to IP69K with integral connectors.

**Note:** See page 3.400.1 for all E-Coil retrofit applications.

**TO ORDER**

**SV20-S38**

<b>Option</b>	<b>Voltage</b>	<b>Termination (VDC)</b>
None (Blank)	<b>Std. Coil</b>	<b>Std. Coil</b>
Manual Override <b>M</b>	<b>0</b> Less Coil**	<b>DS</b> Dual Spades
	<b>10</b> 10 VDC <sup>†</sup>	<b>DG</b> DIN 43650
	<b>12</b> 12 VDC	<b>DL</b> Leadwires (2)
	<b>24</b> 24 VDC	<b>DL/W</b> Leads w/Weatherpak <sup>®</sup> Connectors
<b>Porting</b>	<b>36</b> 36 VDC	<b>DR</b> Deutsch DT04-2P
Cartridge Only <b>0</b>	<b>48</b> 48 VDC	<b>Termination (VAC)</b>
SAE 16 w/SAE 6 Pilot Port <b>16T</b>	<b>24</b> 24 VAC	<b>Std. Coil</b>
	<b>115</b> 115 VAC	<b>AG</b> DIN 43650
	<b>230</b> 230 VAC	<b>AP</b> 1/2 in. Conduit
<b>Seals</b>	**Includes Std. Coil Nut	<b>Termination (VDC)</b>
Buna N (Std.) <b>N</b>	<sup>†</sup> DS, DW or DL terminations only.	<b>E-Coil</b>
Fluorocarbon <b>V</b>	<b>E-Coil</b>	<b>ER</b> Deutsch DT04-2P (IP69K Rated)
Polyurethane <b>P</b>	<b>10</b> 10 VDC	<b>EY</b> Metri-Pack <sup>®</sup> 150 (IP69K Rated)
	<b>12</b> 12 VDC	
	<b>20</b> 20 VDC	
	<b>24</b> 24 VDC	

Coils with internal diode are available. Consult factory.