

# SV08-40 Spool, 4-Way, 2-Position

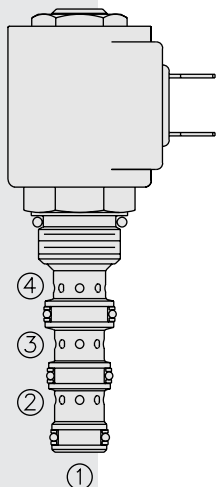

## DESCRIPTION

A solenoid-operated, 4-way, 2-position, direct-acting spool-type, screw-in hydraulic cartridge valve.

## OPERATION

When de-energized, the **SV08-40** flow paths are ③ to ②, and ④ to ①.

When energized, the valve's spool shifts to open ③ to ④, and ② to ①.

All ports are open at cross-over.

**Operation of Manual Override Option:** To override, push button in and twist counterclockwise 180°. The internal spring will push the button out. In this position, the valve may be only partially shifted. To assure full override shift, pull the button out to its fullest extension and hold it in this position.

To return to normal valve function, push button in, twist clockwise 180°, and release. Override will be detented in this position.

## FEATURES

- Continuous-duty rated solenoid.
- Hardened precision spool and cage for long life.
- Optional coil voltages and terminations.
- Efficient wet-armature construction.
- All ports may be fully pressurized.
- Cartridges are voltage-interchangeable.
- Manual override option.
- Optional waterproof E-Coils rated up to IP69K.
- Unitized, molded coil design.
- Compact size.

## RATINGS

**Operating Pressure:** 207 bar (3000 psi)

**Flow:** See Performance Chart

**Internal Leakage:** 82 cc/minute (5 cu. in./minute) max. at 207 bar (3000 psi)

**Temperature:** -40 to 120°C with standard Buna seals

**Coil Duty Rating:** Continuous from 85% to 115% of nominal voltage

**Initial Coil Current Draw at 20°C:** Standard Coil: 1.2 amps at 12 VDC

0.13 amps at 115 VAC (full wave rectified);

E-Coil: 1.4 amps at 12 VDC; 0.7 amps at 24 VDC

**Minimum Pull-in Voltage:** 85% of nominal at 207 bar (3000 psi)

**Filtration:** See page 9.010.1

**Fluids:** Mineral-based or synthetics with lubricating properties at viscosities of 7.4 to 420 cSt (50 to 2000 sus); See Temperature and Oil Viscosity, page 9.060.1

**Installation:** No restrictions; See page 9.020.1

**Cavity:** VC08-4; See page 9.108.1

**Cavity Tool:** CT08-4XX; See page 8.600.1

**Seal Kit:** SK08-4X-MMM; See page 8.650.1

**Coil Nut:** Part No. 7004400;

For E-coils manufactured prior to 1-1-04, see page 3.400.1 for coil nut info.

## SYMBOLS

### USAS/ISO:

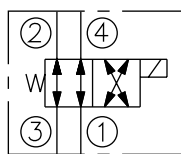

### TRANSITION:

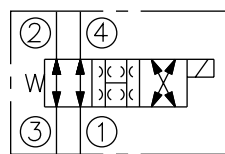

## PERFORMANCE (Cartridge Only)

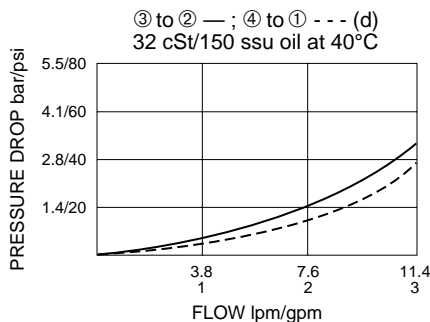

**DIMENSIONS**

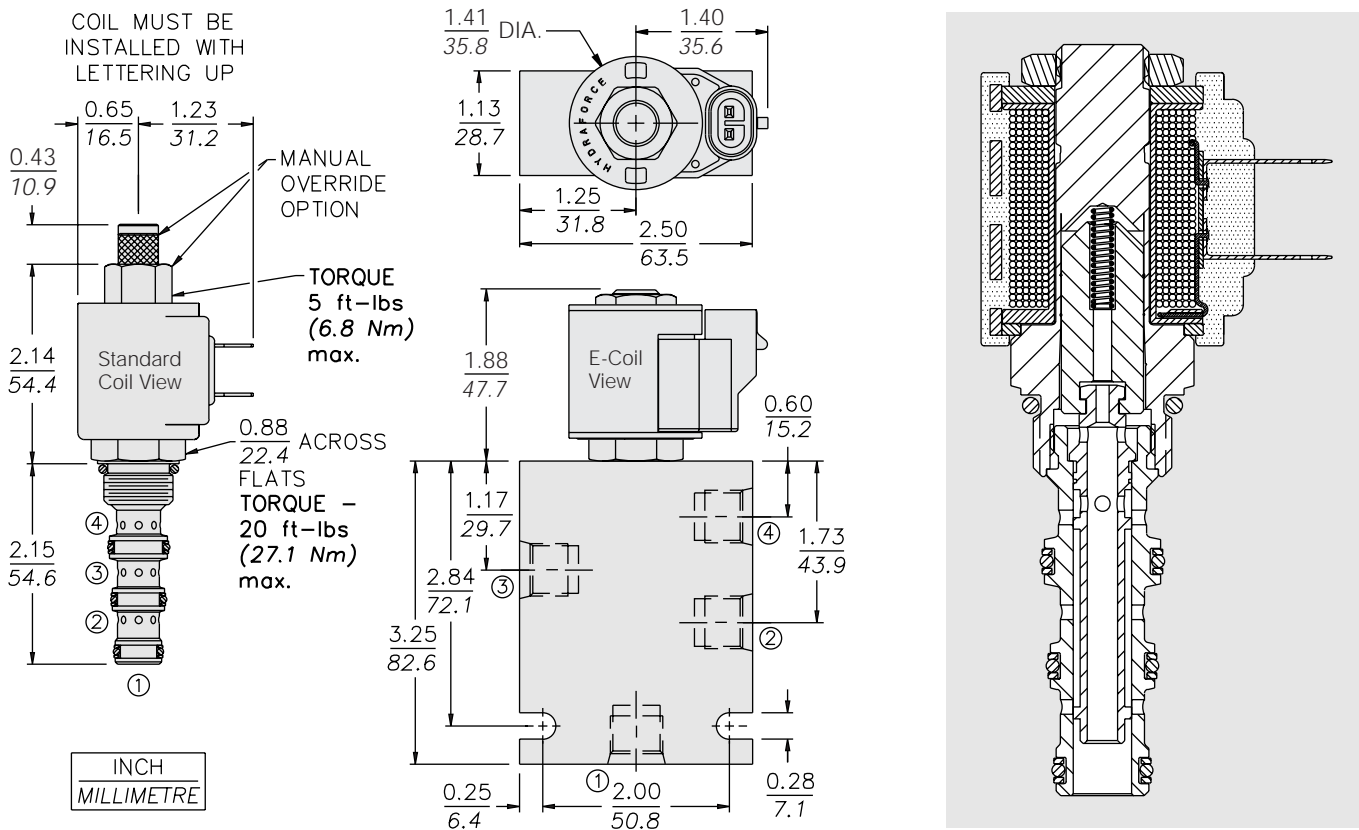

**MATERIALS**

**Cartridge:** Weight: 0.13 kg. (0.28 lbs.); Steel with hardened work surfaces. Zinc-plated exposed surfaces; Buna N O-rings and back-ups standard.

**Standard Ported Body:** Weight: 0.27 kg. (0.60 lbs.); Anodized high-strength 6061 T6 aluminum alloy, rated to 207 bar (3000 psi); Ductile iron bodies available; dimensions may differ. See page 8.008.1.

**Standard Coil:** Weight: 0.11 kg. (0.25 lbs.); Unitized thermoplastic encapsulated, Class H high temperature magnetwire. See page 3.200.1.

**E-Coil:** Weight: 0.14 kg. (0.3 lbs.); Perfect wound, fully encapsulated with rugged external metal shell; Rated up to IP69K with integral connectors.

**See page 3.400.1 for all E-Coil retrofit applications.**

**TO ORDER**

<b>SV08-40</b>		-	-	-	-	-
<b>Option</b>		<b>Voltage</b>		<b>Termination (VDC)</b>		
None (Blank)		<b>Std. Coil</b>		<b>Std. Coil</b>		
Manual Override <b>M</b>		<b>0</b> Less Coil**		<b>DS</b> Dual Spades		
For Manual Override options see page 1.001.1		<b>10</b> 10 VDC†		<b>DG</b> DIN 43650		
		<b>12</b> 12 VDC		<b>DL</b> Leadwires (2)		
		<b>24</b> 24 VDC		<b>DL/W</b> Leads w/Weatherpak® Connectors		
		<b>36</b> 36 VDC		<b>DR</b> Deutsch DT04-2P		
		<b>48</b> 48 VDC		<b>Termination (VAC)</b>		
		<b>24</b> 24 VAC		<b>Std. Coil</b>		
		<b>115</b> 115 VAC		<b>AG</b> DIN 43650		
		<b>230</b> 230 VAC		<b>AP</b> 1/2 in. Conduit		
		**Includes Std. Coil Nut		<b>Termination (VDC)</b>		
		† DS, DW or DL terminations only.		<b>E-Coil</b>		
<b>Porting</b>		<b>E-Coil</b>		<b>ER</b> Deutsch DT04-2P (IP69K Rated)		
Cartridge Only <b>0</b>		<b>10</b> 10 VDC		<b>EY</b> Metri-Pack® 150 (IP69K Rated)		
SAE 6 <b>6T</b>		<b>12</b> 12 VDC				
1/4 in. BSP* <b>2B</b>		<b>20</b> 20 VDC				
3/8 in. BSP* <b>3B</b>		<b>24</b> 24 VDC				
*BSP Body; U.K. Mfr. Only						
<b>Seals</b>						
Buna N (Std.) <b>N</b>						
Fluorocarbon <b>V</b>						

Coils with internal diode are available. Consult factory.