

SV10-41 Spool, 4-Way, 2-Position

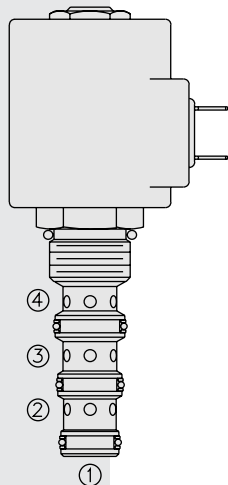

SYMBOLS

USAS/ISO:

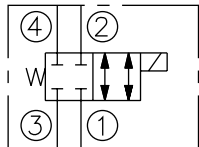

PERFORMANCE (Cartridge Only)

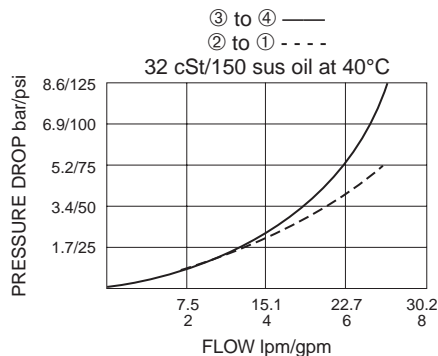

DESCRIPTION

A solenoid-operated, 4-way, 2-position, direct-acting, spool-type, screw-in hydraulic cartridge valve.

OPERATION

When de-energized, the **SV10-41** blocks flow to all ports.

When energized, the spool shifts to open flow between ③ and ④, as well as from ② to ①.

Operation of Manual Override Option: To override, push button in and twist counterclockwise 180°. The internal spring will push the button out. In this position, the valve may be only partially shifted. To assure full override shift, pull the button out to its fullest extension and hold it in this position.

To return to normal valve function, push button in, twist clockwise 180° and release. Override will be detented in this position.

FEATURES

- Continuous-duty rated solenoid.
- Hardened precision spool and cage for long life.
- Optional coil voltages and terminations.
- Efficient wet-armature construction.
- All ports may be fully pressurized.
- Cartridges are voltage interchangeable.
- Manual override option.
- Optional waterproof E-Coils rated up to IP69K.
- Unitized, molded coil design.
- Industry common cavity.

RATINGS

Operating Pressure: 207 bar (3000 psi)

Proof Pressure: 350 bar (5075 psi)

Flow: See Performance Chart

Internal Leakage: 82 cc/minute (5 cu. in./minute) max. at 207 bar (3000 psi)

Temperature: -40 to 120°C with standard Buna seals

Coil Duty Rating: Continuous from 85% to 115% of nominal voltage

Response Time: First indication of change of state with 100% voltage supplied at 80% of nominal flow rating: Energized: 45 msec.; De-energized: 50 msec.

Initial Coil Current Draw at 20°C: Standard Coil: 1.67 amps at 12 VDC;

0.18 amps at 115 VAC (full wave rectified).

E-Coil: 1.7 amps at 12 VDC; 0.85 amps at 24 VDC

Minimum Pull-in Voltage: 85% of nominal at 207 bar (3000 psi)

Filtration: See page 9.010.1

Fluids: Mineral-based or synthetics with lubricating properties at viscosities of 7.4 to 420 cSt (50 to 2000 sus); See Temperature and Oil Viscosity, page 9.060.1

Installation: No restrictions; See page 9.020.1

Cavity: VC10-4; See page 9.110.1

Cavity Tool: CT10-4XX; See page 8.600.1

Seal Kit: SK10-4X-MMM; See page 8.650.1

Coil Nut: Part No. 7004400;

For E-coils manufactured prior to 1-1-04, see page 3.400.1 for coil nut info.

DIMENSIONS

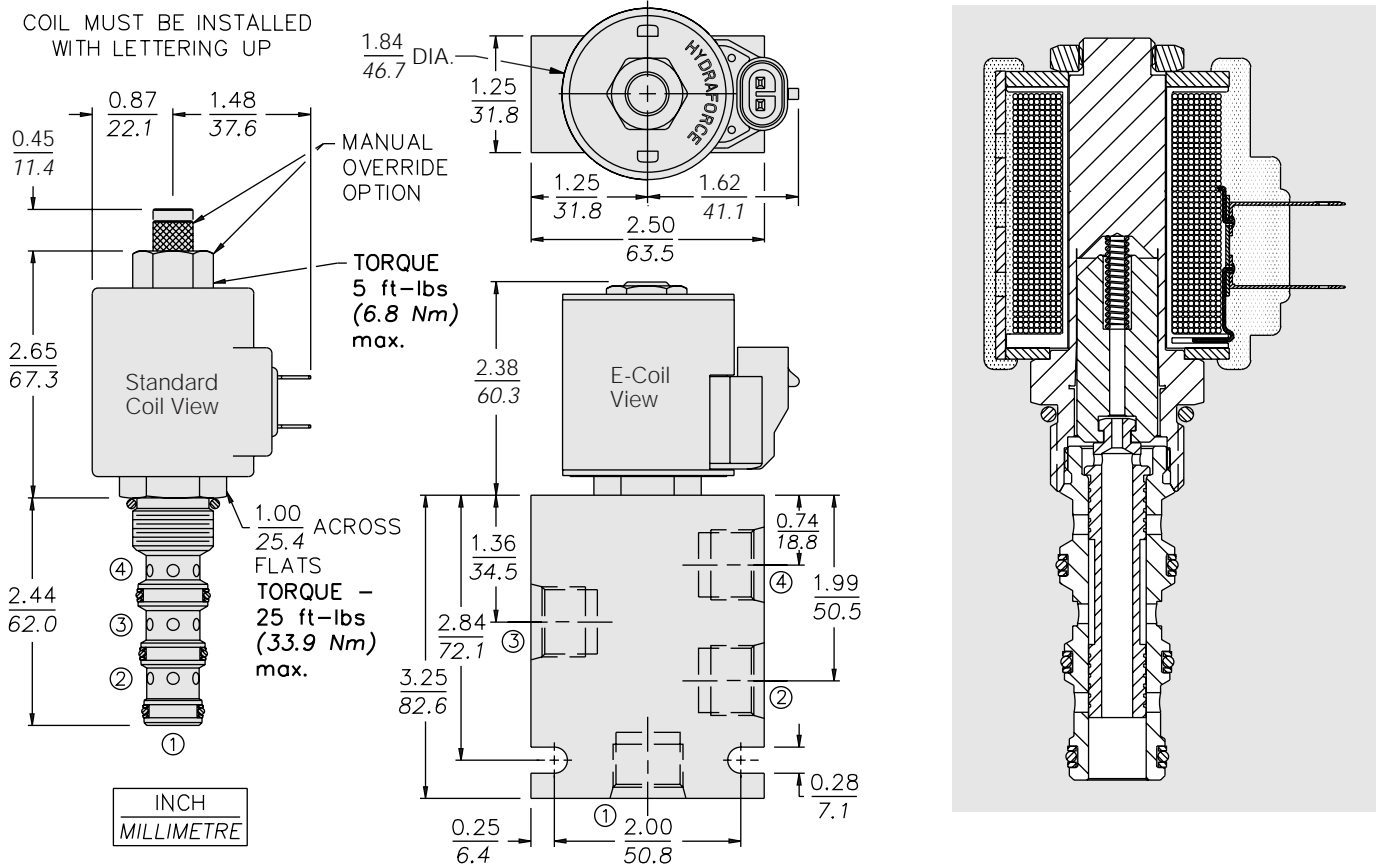

MATERIALS

Cartridge: Weight: 0.20 kg. (0.45 lbs.); Steel with hardened work surfaces. Zinc-plated exposed surfaces. Buna N O-rings and polyester elastomer back-up standard.

Standard Ported Body: Weight: 0.36 kg. (0.80 lbs.); Anodized high-strength 6061 T6 aluminum alloy, rated to 207 bar (3000 psi). Ductile iron bodies available; dimensions may differ. See page 8.010.1.

Standard Coil: Weight: 0.27 kg. (0.60 lbs.); Unitized thermoplastic encapsulated, Class H high temperature magnetwire. See page 3.200.1.

E-Coil: Weight: 0.41 kg. (0.9 lbs.); Fully encapsulated with rugged external metal shell. Rated up to IP69K with integral connectors. **Note: See page 3.400.1 for all E-Coil retrofit applications.**

TO ORDER

SV10-41

Option		Voltage	Termination (VDC)
None (Blank)		Std. Coil	Std. Coil
Manual Override M		0 Less Coil**	DS Dual Spades
Manual Override Y		10 10 VDC†	DG DIN 43650
Manual Override J		12 12 VDC	DL Leadwires (2)
For Manual Override options see page 1.001.1		24 24 VDC	DL/W Leads w/Weatherpak® Connectors
		36 36 VDC	DR Deutsch DT04-2P
Porting		48 48 VDC	Termination (VAC)
Cartridge Only 0		24 24 VAC	Std. Coil
SAE 6 6T		115 115 VAC	AG DIN 43650
SAE 8 8T		230 230 VAC	AP 1/2 in. Conduit
1/4 in. BSP* 2B		**Includes Std. Coil Nut	Termination (VDC)
3/8 in. BSP* 3B		† DS, DW or DL terminations only.	E-Coil
*BSP Body; U.K. Mfr. Only		E-Coil	ER Deutsch DT04-2P (IP69K Rated)
Seals		10 10 VDC	EY Metri-Pack® 150 (IP69K Rated)
Buna N (Std.) N		12 12 VDC	
Fluorocarbon V		20 20 VDC	
		24 24 VDC	

Coils with internal diode are available. Consult factory.